

THE FIELD FLOATER

High Capacity Grain Carts

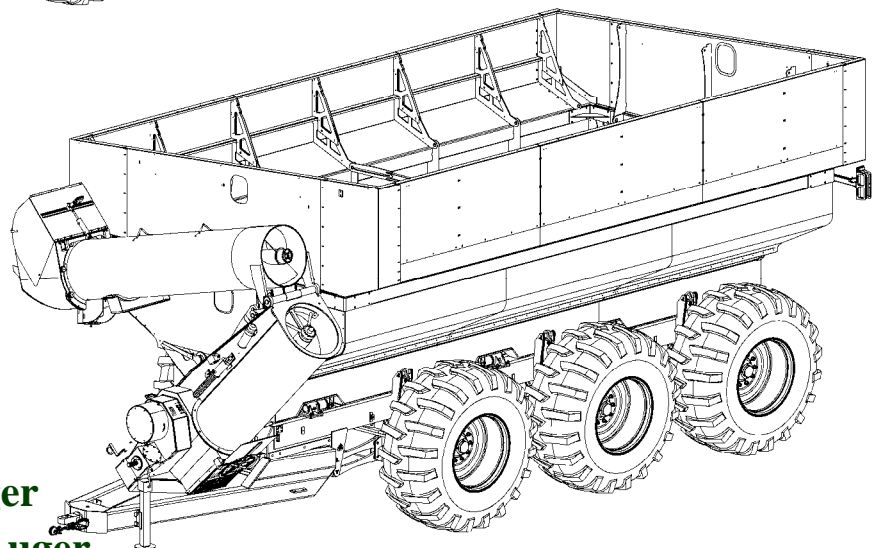

1325 Bushel Extension
1550 Bushel Extension
2000 Bushel Extension
Swivel Upper Vertical Auger
Standard Upper Vertical Auger

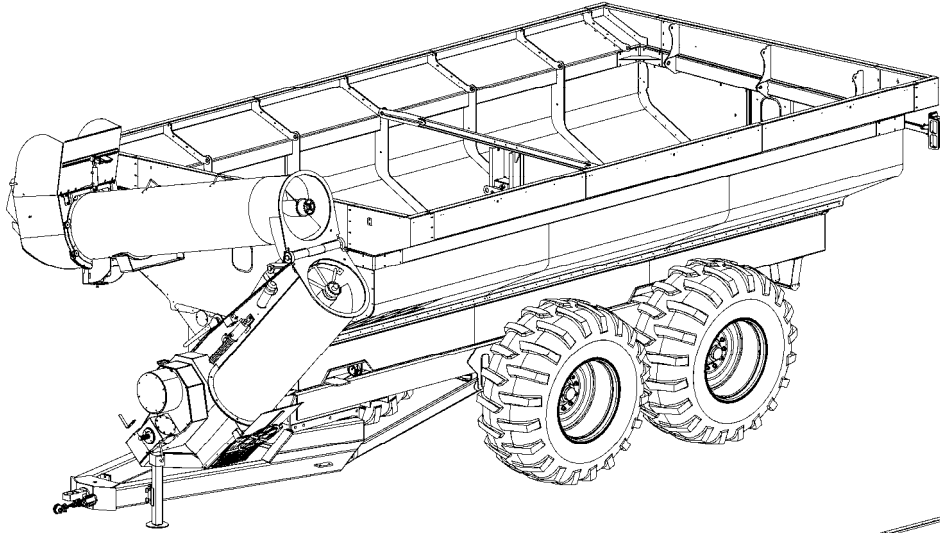

USER MANUAL

May 2010

English Edition



Balzer Inc is dedicated to providing the most reliable and durable AG related products. Balzer Inc has made every attempt to provide the most accurate and readily understandable information on our equipment. Due to our continuing efforts to produce the best products available, upgrades and improvements to our equipment may precede the manual updates. Therefore, contents of this manual are based on information in effect at the time of publication and are subject to change without notice.

To the Purchaser



This is the safety alert symbol. It is used to alert the operator to an instruction concerning the personal safety and risk factor of this equipment. Always observe and heed these very important instructions to promote a safe operation with good preventive maintenance habits.

This new Balzer Inc. product is designed and manufactured to give years of very dependable service when used for the purpose for which it is intended, and when properly maintained.

NEVER OPERATE THIS EQUIPMENT AT SPEEDS OVER 20MPH

NEVER OPERATE THIS EQUIPMENT UNTIL USER FULLY UNDERSTANDS THE COMPLETE CONTENTS OF THIS MANUAL. FOR OWNERS WHO DO NOT OPERATE THIS EQUIPMENT, IT IS THE OWNER'S RESPONSIBILITY THAT THE USER IS PROPERLY INSTRUCTED AND IS FULLY AWARE OF THIS MANUAL'S CONTENTS.

This is important in the safe handling of this equipment and promoting an efficient operation. If there are any questions about areas in this manual, it is important to contact your dealer for clarification.

This machine is warranted as stated on the next page. A registration card is to be filled in by your dealer with your name and address, and promptly returned to the factory. The card provides a ready reference to help you in securing warranty and in answering questions that you may have at some later date.

Operating instructions and parts book are shipped with this machine. If parts of this book are missing or become unreadable, contact your dealer for a new set.

The serial number and identification tag is located to the front of the frame. Please refer to these numbers when parts or warranty communication is necessary.

PLEASE FILL IN THE FOLLOWING INFORMATION FOR YOUR RECORDS:

Date of purchase: _____

Owner's name: _____

Dealer's name : _____

Model #: _____

Serial # Identification # _____

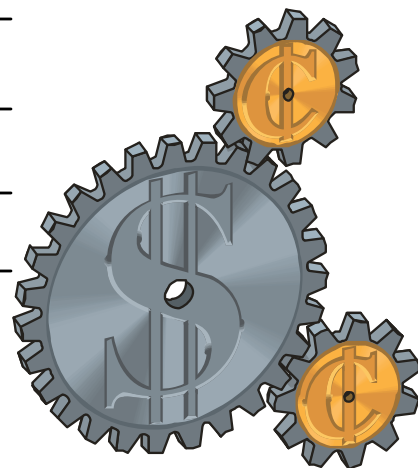

Warranty



WARRANTY MANUFACTURER

Dealer or Distributor understands and agrees that the Manufacturer extends only the following Warranty to customers. In the event Dealer or Distributor extends any additional warranty (such as by enlarging the scope or period of warranty or undertaking a warranty of merchantability or fitness for any particular purpose) or any other obligation whatsoever, Dealer or Distributor shall: (1) be solely responsible therefore (2) have no recourse against Manufacturer thereof and (3) defend, indemnify and hold Manufacturer harmless against any claim or cause of action whatsoever arising out of, or occasioned by, Dealer or Distributor's extension of said additional warranty or obligation.



CERTIFICATE OF GENERAL EQUIPMENT WARRANTY

Balzer Inc. warrants new Products sold by it to be free from defects in material or workmanship for a period of one (1) year after date of delivery to the first user and subject to the following conditions. Balzer Inc.'s obligation and liability under this Warranty is expressly limited to repairing or replacing at Balzer Inc.'s option, any parts which appear to Balzer Inc. upon inspection to have been defective in material or workmanship. Such parts shall be provided at no cost to user, at the business establishment of the authorized Balzer Inc. dealer or distributor of the Product during regular working hours. This Warranty shall not apply to component parts or accessories of Products not manufactured by Balzer Inc. and which carry the warranty of the manufacturer thereof, or to normal maintenance (such as tune-up) or normal maintenance parts (such as oil filters). Replacement or repair parts installed in this Product covered by this Warranty are warranted only for the remainder of this Warranty as if such parts were original components of said Product. **BALZER INC. MAKES NO OTHER WARRANTY, EXPRESS OR IMPLIED, AND MAKES NO WARRANTY OF MERCHANTABILITY OR FITNESS FOR ANY PARTICULAR PURPOSE.**

Balzer Inc.'s obligation under this Warranty shall not include any transportation charges, cost of installation, duty taxes or any other charges whatsoever, or any liability for direct, indirect, incidental or consequential damage or delay. If requested by Balzer Inc. products or parts for which a warranty claim is made are to be returned transportation prepaid to Balzer Inc. Any improper use, including operation after discovery of defective or worn parts, operation beyond rated capacity, substitution or parts not approved by Balzer Inc. company or any alteration or repair by others in such manner as in Balzer Inc. company's judgment affects the Products materially and adversely shall void this Warranty.

“NO EMPLOYEE OR REPRESENTATIVE IS AUTHORIZED TO CHANGE THIS WARRANTY IN ANY WAY OR GRANT ANY OTHER WARRANTY UNLESS SUCH CHANGE IS MADE IN WRITING AND SIGNED BY AN OFFICER OF BALZER INC. AT ITS HOME OFFICE.”

LIABILITY FOR DELAYS

No liability shall attach to Manufacturer direct, or indirect, incidental or consequential damages or expenses due to loss, damage, detention or delay in delivery of Products resulting from acts or delays beyond its control.



Important- Read This First

The registration card is to be filled in completely and promptly returned to factory. It provides a ready reference to help you in securing parts and in answering questions that you may have at a later time.

This card does not put you on a mailing list. Nor is the information on the card made available to anyone else.

We urge the return of this card so that you will receive maximum service benefits.

Where a separate instruction manual has been received by the customer, a parts manual was sent with this machine. If you have not received the parts manual, ask your dealer.

Cut Along Dotted Line and Mail to: Balzer, Inc.
County Road 27 East
P.O. Box 458
Mountain Lake, MN 56159

Warranty Registration Card

This form must be filled out and signed by customer at the time of delivery.

Product _____
Model # _____
Serial # _____
Date of Purchase _____
Customer Name _____
Address _____
City _____ **State** _____ **Zip** _____
Dealers Name _____
Address _____
City _____ **State** _____ **Zip** _____

The above unit and Operator's Manual have been received and I understand and have been thoroughly instructed by my dealer as to Operator's Manual content, equipment care, adjustments, safe operation & explained and reviewed the warranty policy.

Owner's Signature _____



Table of Contents

To the Purchaser.....	Page 3
Warranty.....	Page 4
Table of Contents.....	Page 7
Safety.....	Page 8
Operation.....	Page 28
Lubrication and Maintenance.....	Page 56
Troubleshooting.....	Page 74

Safety





The following Safety Alert Symbols mean **ATTENTION! BECOME ALERT! YOUR SAFETY IS INVOLVED!** They stress an attitude of “Heads Up for Safety” and can be found throughout this Operation Manual and on the machine itself.

BEFORE YOU ATTEMPT TO OPERATE THIS EQUIPMENT, READ AND STUDY THE FOLLOWING SAFETY INFORMATION. IN ADDITION, MAKE SURE THAT EVERY INDIVIDUAL WHO OPERATES OR WORKS WITH THIS EQUIPMENT, WHETHER FAMILY MEMBER OR EMPLOYEE, IS FAMILIAR WITH THESE SAFETY PRECAUTIONS.

Our Company **ALWAYS** takes operator safety into consideration when designing its machinery, guards, and exposed moving parts for operator protection. However, some areas can **NOT** be guarded or shielded in order to assure proper operation. In addition to this Operation Manual; decals on the machine warn of further danger and should be read and observed closely.

 DANGER	“DANGER” indicates an imminently hazardous situation which, if not avoided, will result in death or serious injury.
--------------------------------------------------------------------------------------------------	---------------------------------------------------------------------------------------------------------------------

 WARNING	“WARNING” indicates a potentially hazardous situation which, if not avoided, could result in death or serious injury.
----------------------------------------------------------------------------------------------------	-----------------------------------------------------------------------------------------------------------------------

 CAUTION	“CAUTION” indicates a potentially hazardous situation which, if not avoided, may result in minor or moderate injury.
----------------------------------------------------------------------------------------------------	----------------------------------------------------------------------------------------------------------------------

READ and follow the instructions on all decals.

REMEMBER! It is the owner's responsibility for communicating information on the safe use and proper maintenance of this machine! This includes providing understandable interpretation of these instructions for operators who are not fluent in reading English.



MANDATORY SAFETY SHUTDOWN PROCEDURE

BEFORE cleaning, adjusting, lubricating or servicing the unit:

1. Remove the ignition key from the power unit engine.
2. **Make sure that all movement of the unit has ceased. ONLY** when you have taken these precautions can you be sure it is safe to proceed. Failure to follow the above procedure, could lead to death or serious bodily injury.
3. Attach jack to unit and raise up to transfer weight to the jack.
4. Keep hitch pin attached to help prevent unit from accidentally moving.
5. Disconnect the PTO.

ADDITIONAL SAFETY REMINDERS

USER/OPERATOR SAFETY PRACTICES are included in this Operation Manual and are intended to promote **SAFE OPERATION** of the unit.

These guidelines do not preclude the use of good judgment, care, and common sense as may be indicated by the particular job site work conditions.

It is essential that operators be physically and mentally free of mind altering drugs and chemicals and thoroughly trained in the safe operation of the unit. Such training should be presented completely to all new operators and not condensed for those claiming previous experience.

Some photographs used in this manual may show Doors, Guards, and Shields open or removed for illustration purposes **ONLY. BE SURE** that all Doors, Guards, and Shields are in their proper operating positions **BEFORE** operating the unit. **NEVER** operate this unit with any guards or shields not in place. Replace any missing or damaged ones.

Keep hands and feet away from all moving parts.

The operator **MUST** know the capabilities and work applications for the machine, and operate it at speeds slow enough to insure complete control at all times. When working on uneven ground or near the edge of roadbeds, there is no substitute for good judgment and only operators with sufficient experience should attempt such work.

NEVER assume that everybody is as safety conscious as you are.



PERSONAL SAFETY

- **Do not** allow minors and any unqualified trained personnel to operate or be near the unit unless properly supervised!
- **Do not** allow anyone to ride on the unit at anytime!
- **Never leave** the unit running unattended!
- **Always wear** appropriate personal safety gear as called for by the job or working conditions!
- **Never wear** loose clothing while working around moving parts.
- **Always be aware** of pinch point areas on the unit!
- Keep hands, feet, hair and clothing away from moving parts.
- Stop and disengage PTO and shut off tractor before doing any adjusting or servicing to unit.
- **Never step** on or over PTO drive-line at any time.

PER OPERATION SAFETY

- **Before each** tow: Check that the tail lights, brake lights and turn signals work correctly.
- Improper electrical connection between the tow vehicle and the trailer will result in inoperable lights and electric brakes, and can lead to collision.
- **Do not** operate on public roads after dark without warning lights.
- Be sure the rear of the unit has a clean “slow moving vehicle” emblem properly displayed. If towing at less than 20 mph on any public roadway at night, proper warning and running lights are necessary as required by state law!
- **DO NOT** pull the unit without having safety chains attached to the tractor.
- Refer to local transportation laws for regulation on safety chain use. Maximum speed is 20 mph.
- Size of tractor must be sufficient to maintain vehicle stability when fully loaded.
- **Always use a hitch pin that has a safety clip pin!**
- If unit is equipped with the braking system, check oil level and braking capacity with a full load on unit before operating the unit.
- Check wheel bolts daily and tighten them as required.
- Keep hands, feet, hair and clothing away from moving parts.
- Insure all guards are in place before using.
- Replace any parts which show signs of excessive wear, cracking, or likelihood of failure, with original equipment service parts.
- Be familiar with the levers controlling all hydraulically controlled components.
- **Before loading**, make sure that the unit does not have any foreign object or material in it that can cause equipment damage or personal injury.
- **Never enter the unit** unless it is absolutely necessary. If a unit must be entered, take proper safety precautions. This includes someone at the site, outside the unit and a proper life support system. Contact your Balzer dealer for more information before you enter a unit.
- Check that PTO slides freely, is not damaged and is secured properly to tractor and unit. Make sure that there is approximately 1/3 over-lap of engagement. (Refer to Draw-Bar Adjustment)



OPERATION SAFETY

- **Be alert** and avoid loose, soft or icy surface conditions that could cause tipping or loss of control.
- When possible, travel by driving up or down the slope. Avoid traveling along side hills.
- **Always check** the job site for hazardous terrain, obstructions or bystanders.
- Slow down prior to going down any steep grade.
- **Never** take tractor out of gear when going downhill.
- **Do not exceed** the maximum weight carrying capacity of the equipment or the tractor manufacturer's maximum towing capacity; whichever is lower.
- Never use a tractor that is not recommended for the type of unit you are using. If you have any questions contact your Balzer Dealer.
- When agitating a pit, always be sure there is adequate ventilation in any confined area. (If Applicable)
- Keep hands, feet, hair and clothing away from moving parts.
- **Do not stand** in front, behind, or along side of the machine when machine is running.
- When parking unit, block wheels securely before unhitching from tractor.

TOWING SAFETY

- **THE MAX SPEED OF THE TOWING TRACTOR IS 20 MPH.**
- Observe recommended maximum road speeds, or local speed limits which ever may be lower.
- **Always move unit with a farm tractor only!**
- **ALWAYS ENGAGE** power-steering before turning. (Lever In Float Position)
- **DO NOT DISENGAGE** power-steering before turning process is over. (Lever In Float Position)
- **Stopping distance** increases with speed and weight of towed loads and on slopes. Towed loads with or without brakes that are too heavy for the tractor or are towed too fast can cause loss of control. Consider the total weight of the equipment and its load.
- Tractor must be heavy and powerful enough with adequate braking power for the towed load. Use additional caution when towing loads under adverse surface condition, when turning, and on inclines.

HYDRAULIC SYSTEM SAFETY

- **Do not smoke** while working on hydraulic systems!
- **Never** use your hand to search for hydraulic fluid leaks; escaping fluid under pressure can be invisible and can penetrate the skin and cause a serious injury!
- **USE A SCRAP PIECE OF CARDBOARD TO CHECK FOR LEAKS!**
- **If any fluid is injected** into your skin, see a doctor at once! Notify medical staff that there is an injection injury with hydraulic fluid. Injected fluid must be surgically removed by a doctor familiar with this type of injury or gangrene may result!
- **Do not attempt** to loosen or disconnect any hydraulic lines, hoses or fittings without first relieving hydraulic circuit pressure. Also, be careful not to touch any hydraulic components that have been in recent operation because they can be extremely hot!
- **Always** replace hydraulic components with manufacturer recommended replacement parts. Improperly rated components may result in system failure and/or injuries.
- Contact your local Balzer dealer to order replacement parts.

SAFETY SIGNS ARE IMPORTANT

Safety signs or decals provide very important information and instructions designed to alert you to dangers and hazards that can be present during operation of this equipment. However, safety sign instructions must be read, understood and followed to be effective.

REPLACEMENT OF SAFETY SIGNS

Safety signs or decals must be kept clean and readable. If they become unreadable for any reason, they must be replaced with an identical replacement decal. Safety decals must also be replaced if parts are repaired or replaced with new parts that do not already include the necessary safety decals.

APPLICATION OF SAFETY DECALS

Surface preparation is very important for safety decals to properly adhere. Grease, oil and dirt must be removed and the surface must be smooth and dry.

Most decals have a split backing which is meant to be removed from the split outward. To apply the decals follow these procedures:

1. Position the decal in the proper location and hold firmly over the largest portion of backing.
2. Use one hand to hold the decal in position, with the other hand carefully roll the loose end over and peel the backing outward. When the backing is removed as described and shown (Fig. 1), with even and gradual pulling, the decal will roll onto the surface smooth and wrinkle free.
3. With the smallest portion of the decal attached, the same procedure can be applied to the other half.

4. When the decal has been attached in place, use a cloth or soft paper towel to burnish the decal onto the cleaned surface. Work gently from the middle outwards to avoid creating any wrinkles.

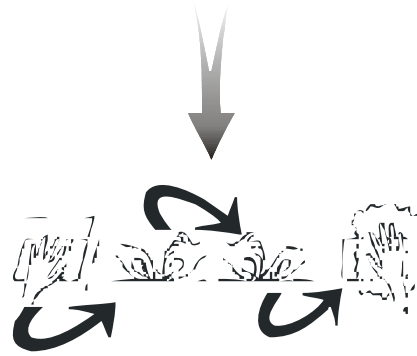

Fig. 1



REPLACEMENT DECALS

Order replacement decals by part number through your nearest dealer. Part numbers are printed on each decal.





! DANGER

MOVING PARTS HAZARD

- Keep hands, clothing, and hair away from moving belts and parts.
- Replace guard before operating.

21730

! DANGER

STOP: WAIT FOR ALL MOVEMENT TO STOP BEFORE SERVICING OR OPENING OF SHIELDS.

LOOK: THE IGNITION KEY IS REMOVED.

LISTEN: FOR ALL MOVEMENT TO STOP, ROTATING PARTS CONTINUE TO ROTATE AFTER POWER IS SHUT OFF.

14175



! DANGER

Decals

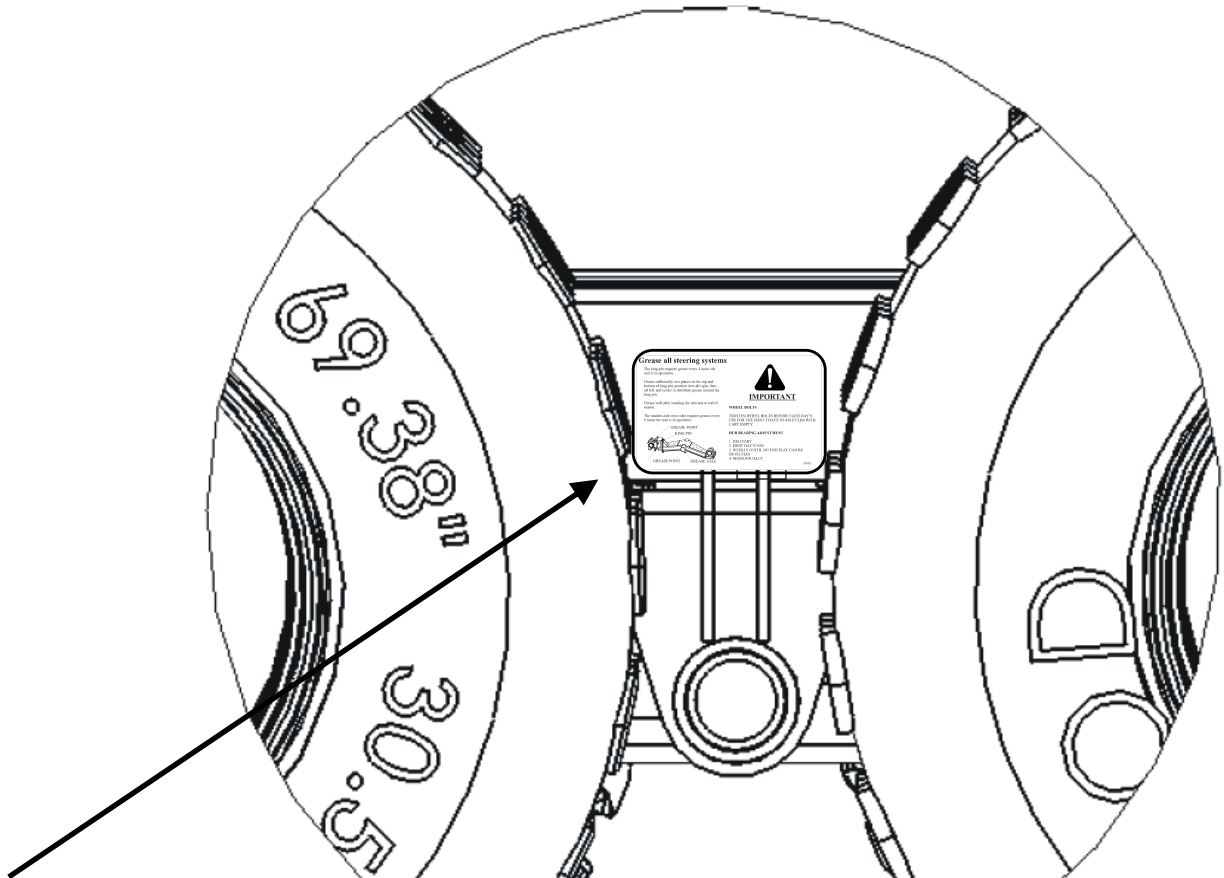

Grease all steering systems

The king pin requires grease every 4 hours the unit is in operation.

Grease sufficiently two places on the top and bottom of king pin, position tires all right, then all left, and center to distribute grease around the king pin.

Grease well after washing the unit and at end of season.

The tandem axle cross tube requires grease every 8 hours the unit is in operation.

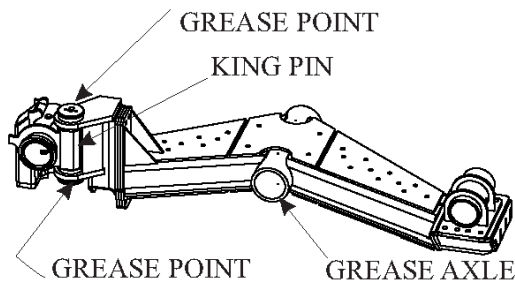

IMPORTANT

WHEEL BOLTS

TIGHTEN WHEEL BOLTS BEFORE EACH DAY'S USE FOR THE FIRST 5 DAYS TO 450 FT/LBS WITH CART EMPTY.

HUB BEARING ADJUSTMENT

1. DELIVERY
2. FIRST DAY'S USE
3. WEEKLY (UNTIL NO END PLAY CAN BE DETECTED)
4. SEMIANNUALLY

37601

P# 37601

Decals



TWO PUMPS
800-1400 ACRES
OR
50 TO 100 HOURS

P# 27787

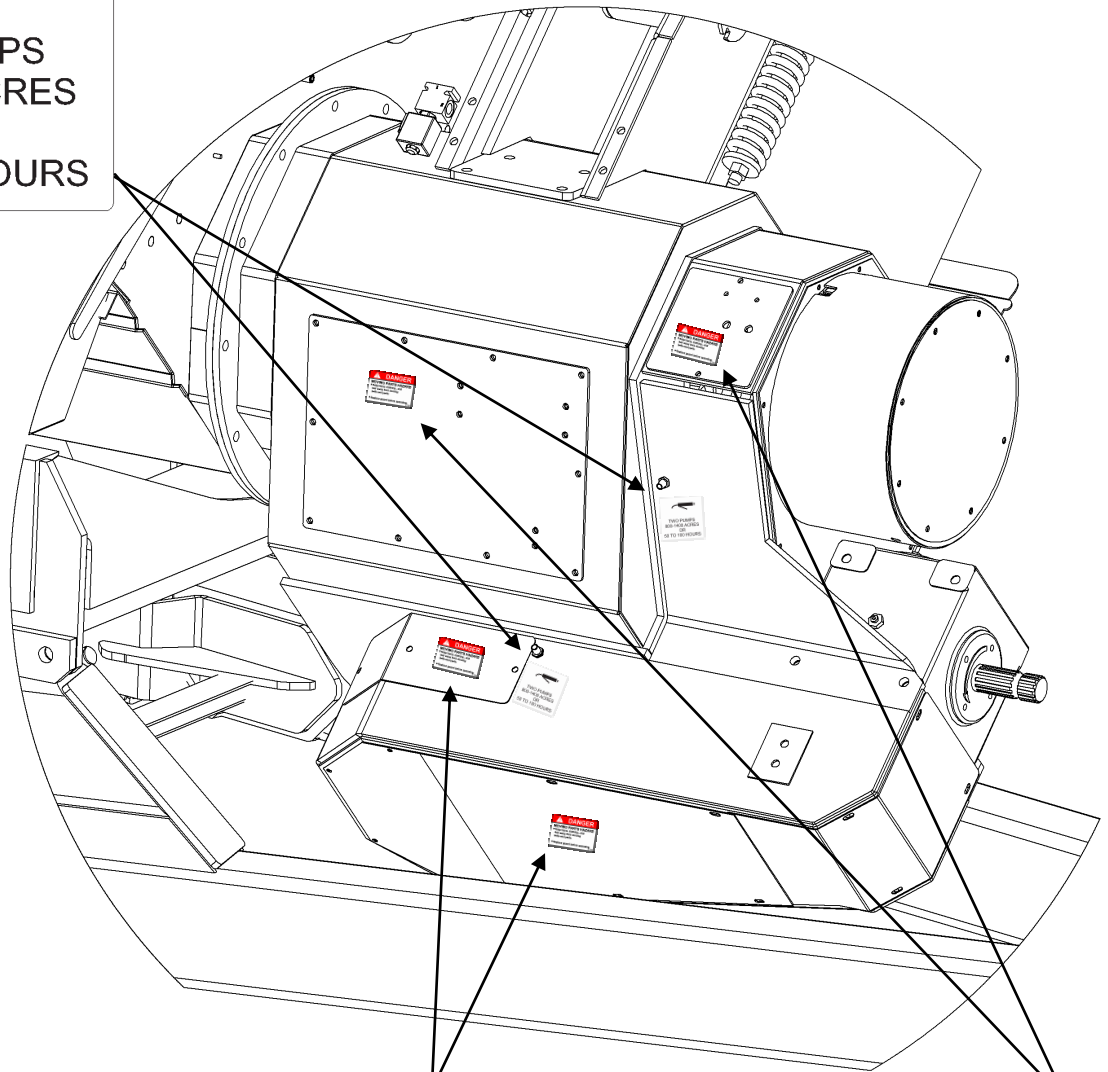

 **DANGER**

MOVING PARTS HAZARD

- Keep hand, clothing , and hair away from moving belts and parts.
- Replace guard before operating.

21730

P# 21730

Decals



P# 72725



P# 90295

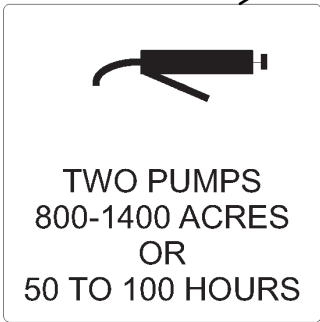
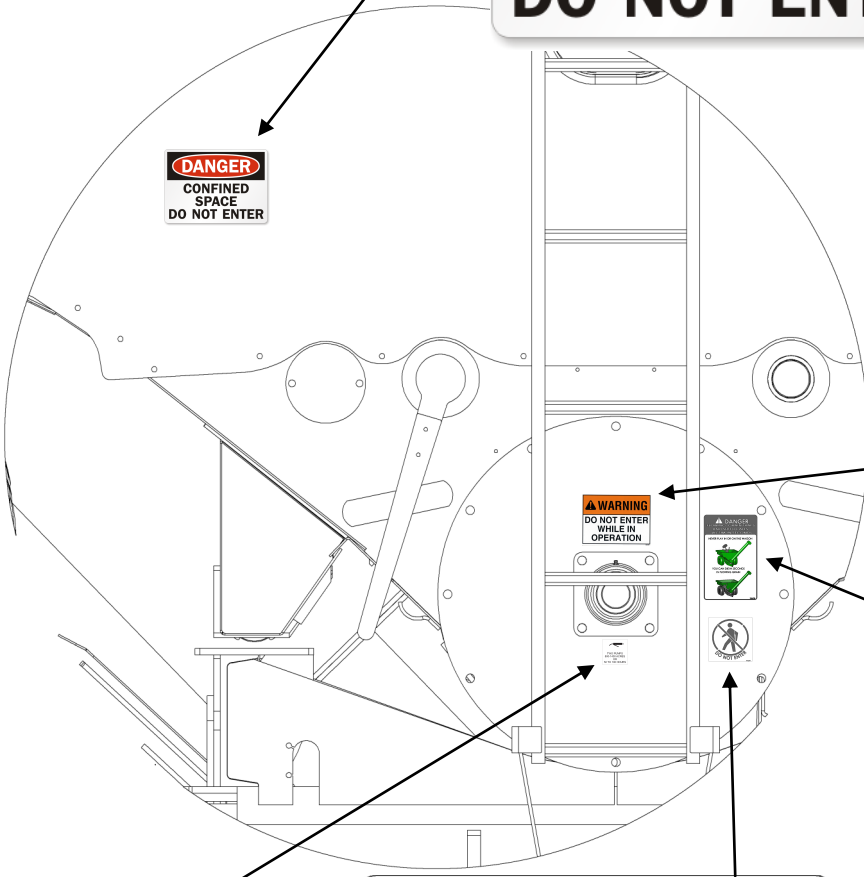

P# 27787



P# 94699

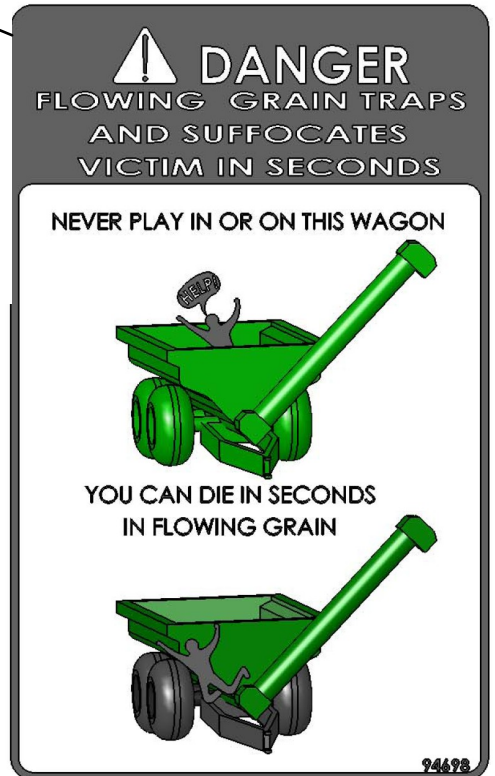

P# 94698

Decals

GRAIN CART OPERATION INSTRUCTIONS

PRE OPERATION CHECK

- MAKE SURE ALL SAFETY SHIELDS ARE IN PLACE.
- MAKE SURE THERE IS NO FROZEN MATERIAL TO OBSTRUCT THE GRAIN DOORS OR AUGERS.
- MAKE SURE TRACTOR DRAW BAR MATCHES STANDARDS SHOWN IN DRAWBAR ADJUSTMENT DECAL.

ATTACHING TO TRACTOR

- ATTACH TRACTOR DRAWBAR TO GRAIN CART HITCH WITH PROPERLY SIZED HITCH PIN THAT HAS A RETAINER DEVICE.
- CRANK TRAILER JACK TO SLOWLY PLACE PRESSURE ON DRAWBAR. PLACE JACK ON SIDE OF TONGUE TO PROVIDE MAXIMUM GROUND CLEARANCE.
- CHECK THAT TRACTOR AND PTO HAVE PROPER SIZE SPLINES. CHECK THAT PTO SLIDES FREELY AND IS NOT DAMAGED. ATTACH PTO SHAFT TO TRACTOR SECURELY AS REQUIRED BY ITS LOCKING MECHANISM. PTO SHOULD HAVE APPROXIMATELY 1/3 OVER-LAP.
- ATTACH HYDRAULIC LINES MAKING SURE THE CONNECTORS ARE CLEAN AND IN GOOD REPAIR.

HOSE COLOR MARKINGS

- RED - BRAKE CYLINDERS
- YELLOW - STEERING LOCK-OUT
- BLUE - GRAIN DOORS
- BLUE/RED - SWIVEL AUGER CONTROL
- ORANGE - AUGER FOLDING
- NO COLOR - CLUTCH

INITIAL START-UP

- NEVER OPERATE THIS MACHINE IF SHIELDS ARE MISSING OR IF PERSONS ARE IN OR ON THIS MACHINE. DO NOT LEAVE TRACTOR SEAT. KEEP EVERYONE AWAY WHILE OPERATING THIS MACHINE.
- OPERATE ALL HYDRAULIC CONTROLS TO BECOME FAMILIAR WITH THE FUNCTION OF EACH TRACTOR LEVER AND TO VISUALLY SEE THAT THE GRAIN CART IS RESPONDING CORRECTLY.
- ENGAGE PTO SLOWLY WITH TRACTOR THROTTLE AT IDLE. WATCH AND LISTEN TO CONFIRM THAT THE GRAIN CART IS OPERATING PROPERLY. RUN AT FAST IDLE FOR 5 MINUTES DISENGAGE PTO AND SHUT OFF TRACTOR ENGINE AND REMOVE KEYS FROM IGNITION. MAKE ALL ADJUSTMENTS BEFORE ANY FURTHER OPERATING IS ATTEMPTED.

IN FIELD PROCEDURES

- ALWAYS CLOSE GRAIN DOORS BEFORE DISENGAGING PTO AND ALWAYS ENGAGE PTO BEFORE OPENING GRAIN DOORS, OR ENGAGING HORIZONTAL CLUTCH.
- BE SURE GRAIN DOORS ARE CLOSED BEFORE LOADING.
- ALWAYS ENGAGE STEERING LOCK-OUT CYLINDERS BEFORE ATTEMPTING TO BACK-UP THIS GRAIN CART.
- NEVER TURN A LOADED CART WITHOUT PUTTING STEERING HOSE IN FLOAT.

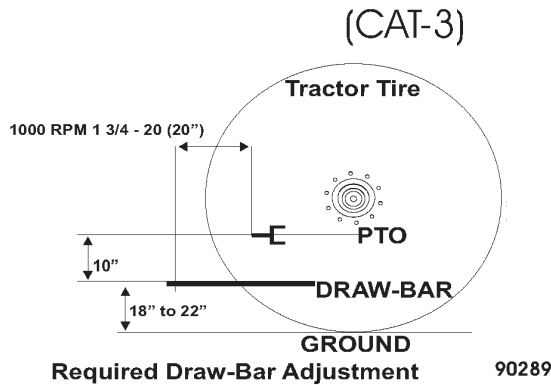

DANGER

MOVING PARTS HAZARD

- Keep hand, clothing , and hair away from moving belts and parts.
- Replace guard before operating.

21730

P# 21730

DANGER

ROTATING AUGER

NEVER OPEN OR CLOSE DOOR WITH AUGER RUNNING.

KEEP YOURSELF AND CLOTHING CLEAR OF AUGER.

90241

P# 90241

CAUTION

MAXIMUM PTO SPEED
1000 RPM

90175

P# 90175

P# 90289

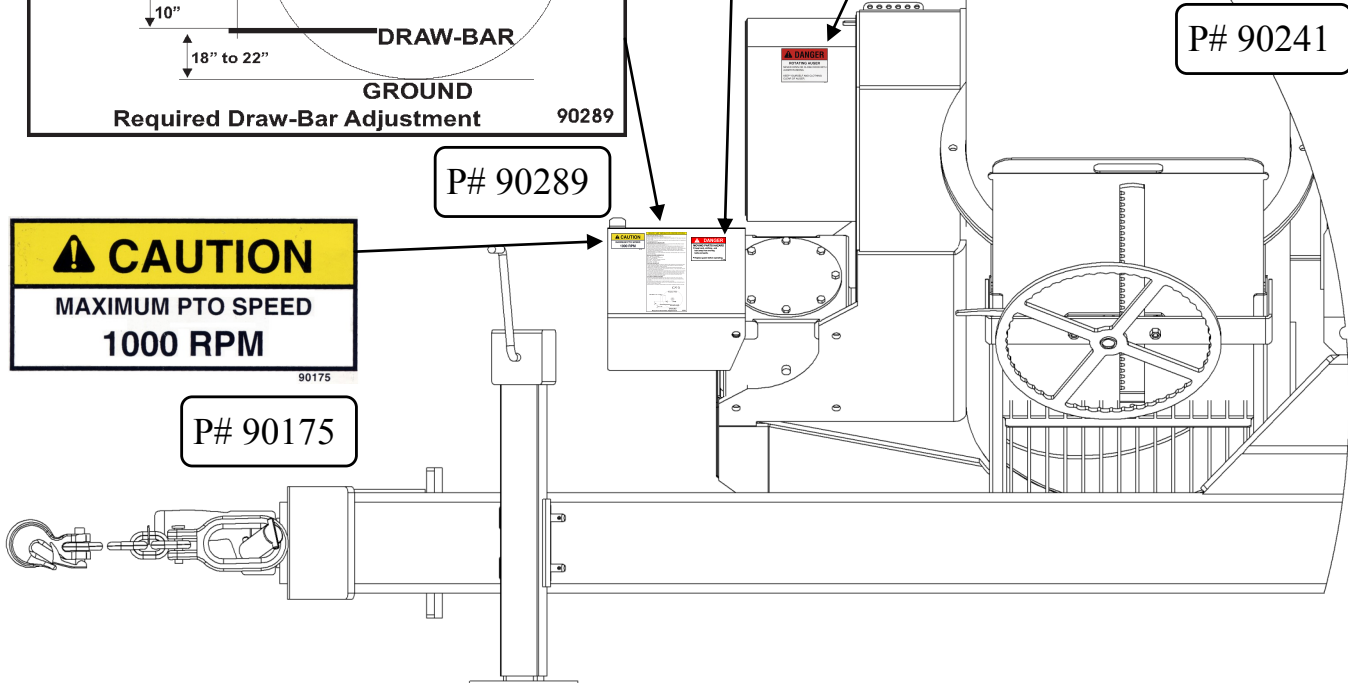

Decals

P# 82904	P# 90178	P# 90177	P# 94698	P# 85026
P# 90173	P# 90179	P# 90172	P# 94699	P# 90323
P# 90244	P# 90242	P# 90174	P# 90176	

Serial Number /
Reference Number

P# 12484

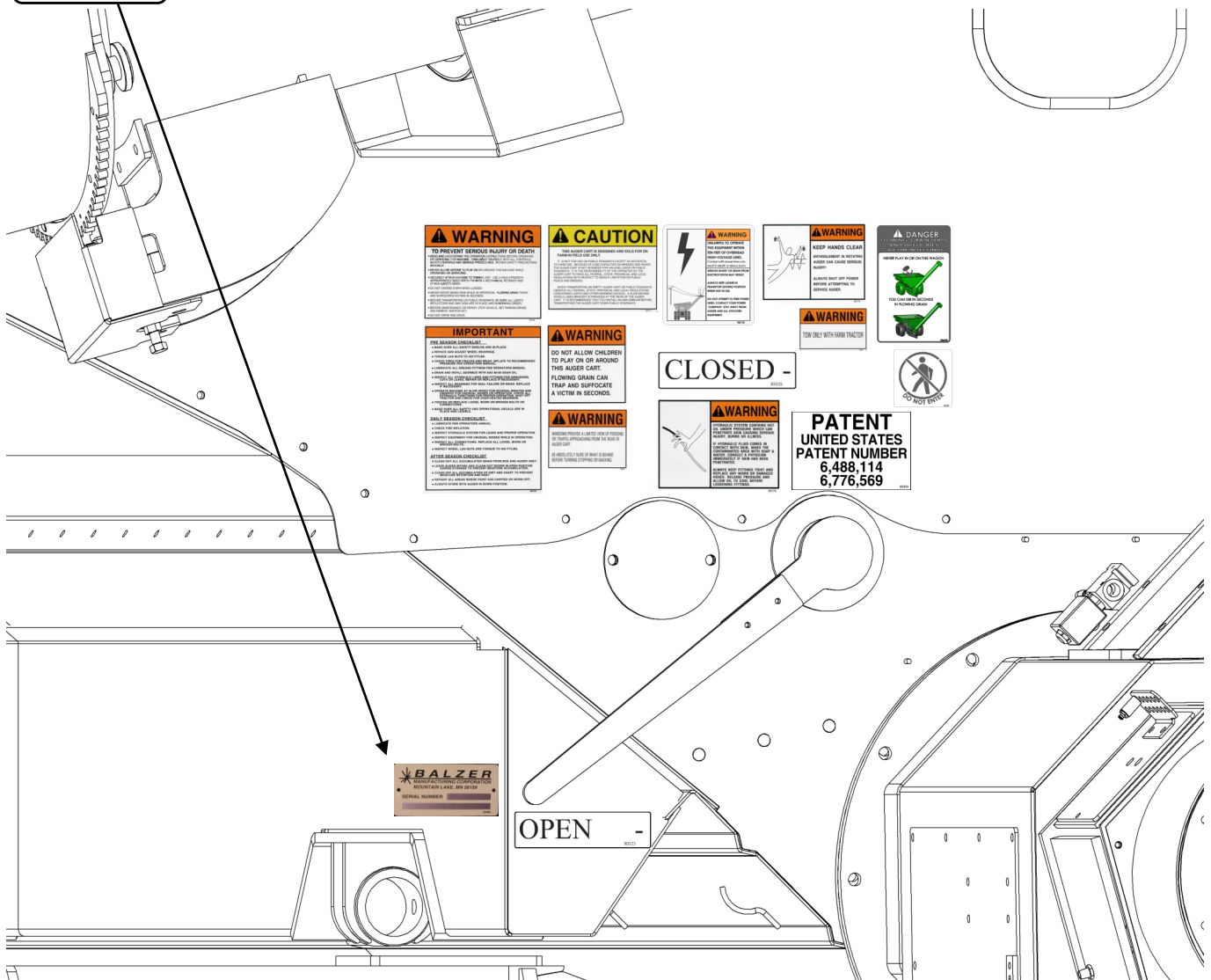

WARNING
TO PREVENT SERIOUS INJURY OR DEATH...
DO NOT OPERATE THIS FORKTRUCK WITH A LOAD EXCEEDING THE RATED CAPACITY...
DO NOT OPERATE THIS FORKTRUCK WITH A LOAD EXCEEDING THE RATED CAPACITY...
DO NOT OPERATE THIS FORKTRUCK WITH A LOAD EXCEEDING THE RATED CAPACITY...

CAUTION
THE REAR OF THIS FORKTRUCK IS HEAVY AND...
FURNISHED FOR USE ONLY...
DO NOT OPERATE THIS FORKTRUCK WITH A LOAD EXCEEDING THE RATED CAPACITY...

WARNING
DO NOT ALLOW CHILDREN TO PLAY ON OR AROUND THIS FORKTRUCK...
FLOORING GRASS CAN TRAP AND SUFFOCATE A VICTIM IN SECONDS.

IMPORTANT
PRE-START CHECKLIST...
CHECK THE FOLLOWING BEFORE OPERATING THE FORKTRUCK...
CHECK THE FOLLOWING BEFORE OPERATING THE FORKTRUCK...

WARNING
DO NOT OPERATE THIS FORKTRUCK WITH A LOAD EXCEEDING THE RATED CAPACITY...
DO NOT OPERATE THIS FORKTRUCK WITH A LOAD EXCEEDING THE RATED CAPACITY...

WARNING
TO PREVENT SERIOUS INJURY OR DEATH...
DO NOT OPERATE THIS FORKTRUCK WITH A LOAD EXCEEDING THE RATED CAPACITY...

WARNING
KEEP HANDS CLEAR...
REPOSITIONING IN AVOIDANCE...
DO NOT ATTEMPT TO REVERSE...
DO NOT ATTEMPT TO REVERSE...

DANGER
NEVER PLAY IN OR ON THE PATH OF...
YOU CAN BE INJURED...
IN THESE AREAS...

WARNING
TOP ONLY WITH FORK TRACTOR

DO NOT DRIVE

CLOSED -

WARNING
DO NOT OPERATE THIS FORKTRUCK WITH A LOAD EXCEEDING THE RATED CAPACITY...
DO NOT OPERATE THIS FORKTRUCK WITH A LOAD EXCEEDING THE RATED CAPACITY...

PATENT
UNITED STATES
PATENT NUMBER
6,488,114
6,776,569

Decals

WARNING

TO PREVENT SERIOUS INJURY OR DEATH

- READ AND UNDERSTAND THE OPERATION INSTRUCTIONS BEFORE OPERATING OR SERVICING THIS MACHINE. FAMILIARIZE YOURSELF WITH ALL CONTROLS, SAFETY FEATURES AND SERVICE PROCEDURES. REVIEW SAFETY PRECAUTIONS ANNUALLY.
- NEVER ALLOW ANYONE TO PLAY ON OR AROUND THIS MACHINE WHILE OPERATING OR SERVICING.
- SECURELY ATTACH MACHINE TO TOWING UNIT. USE A HIGH STRENGTH APPROPRIATELY SIZED HITCH PIN WITH A MECHANICAL RETAINER AND ATTACH SAFETY CHAIN.
- DO NOT EXCEED 5 MPH WHEN LOADED.
- NEVER ENTER GRAIN TANK WHILE IN OPERATION. **FLOWING GRAIN** TRAPS AND SUFFOCATES VICTIMS IN SECONDS.
- BEFORE TRANSPORTING ON PUBLIC ROADWAYS, BE SURE ALL LIGHTS REFLECTORS AND SMV SIGN ARE IN PLACE AND IN WORKING ORDER.
- BEFORE MAINTENANCE OR REPAIR, STOP VEHICLE, SET PARKING BRAKE AND REMOVE IGNITION KEY.
- DO NOT DRINK AND DRIVE.

90178

P# 90178

CAUTION

THIS AUGER CART IS DESIGNED AND SOLD FOR ON FARM-IN FIELD USE ONLY.

IT IS NOT FOR USE ON PUBLIC ROADWAYS EXCEPT AS INCIDENTAL TO FARM USE. BECAUSE OF LOAD CAPACITIES ON BRIDGES AND ROADS THE AUGER CART IS NOT INTENDED FOR HAULING LOADS ON PUBLIC ROADWAYS. IT IS THE RESPONSIBILITY OF THE OPERATOR OF THE AUGER CART TO HEED ALL FEDERAL, STATE, PROVINCIAL AND LOCAL REGULATIONS WITH RESPECT TO WEIGHT LIMITATION ON PUBLIC ROADS AND BRIDGES.

WHEN TRANSPORTING AN EMPTY AUGER CART ON PUBLIC ROADWAYS OBSERVE ALL FEDERAL, STATE, PROVINCIAL AND LOCAL REGULATIONS CONCERNING LIGHTS AND OTHER WARNING DEVICES. A SLOW MOVING VEHICLE (SMV) BRACKET IS PROVIDED AT THE REAR OF THE AUGER CART. IT IS RECOMMENDED THAT YOU INSTALL AN SMV EMBLEM BEFORE TRANSPORTING THE AUGER CART DOWN PUBLIC ROADWAYS.

90177

P# 90177

WARNING

DO NOT ALLOW CHILDREN TO PLAY ON OR AROUND THIS AUGER CART.

FLOWING GRAIN CAN TRAP AND SUFFOCATE A VICTIM IN SECONDS.

P# 90179



Decals

IMPORTANT

PRE SEASON CHECKLIST

- MAKE SURE ALL SAFETY SHIELDS ARE IN PLACE.
- REPACK AND ADJUST WHEEL BEARINGS.
- TORQUE LUG NUTS TO 420 FT/LBS.
- CHECK TIRES FOR CRACKS AND WEAR. INFLATE TO RECOMMENDED PRESSURE PER OPERATORS MANUAL.
- LUBRICATE ALL GREASE FITTINGS PER OPERATORS MANUAL.
- DRAIN AND REFILL GEARBOX WITH SAE 80-50 GEAR OIL.
- INSPECT ALL HYDRAULIC LINES AND FITTINGS FOR ABRASIONS, CUTS OR LEAKS. REPAIR OR REPLACE IF NECESSARY.
- INSPECT ALL BEARINGS FOR SEAL FAILURE OR WEAR. REPLACE IF NECESSARY.
- OPERATE MACHINE AT SLOW SPEED FOR SEVERAL MINUTES AND OBSERVE FOR UNUSUAL NOISES OR OPERATION. CHECK ALL HYDRAULIC FUNCTIONS FOR PROPER OPERATION. SHUT OFF TRACTOR AND CHECK FOR OVER-HEATED BEARINGS.
- TIGHTEN OR REPLACE LOOSE, WORN OR BROKEN BOLTS OR CONNECTIONS.
- MAKE SURE ALL SAFETY AND OPERATIONAL DECALS ARE IN PLACE AND LEGIBLE.

DAILY SEASON CHECKLIST

- LUBRICATE PER OPERATORS ANNUAL.
- CHECK TIRE INFLATION.
- INSPECT HYDRAULIC SYSTEM FOR LEAKS AND PROPER OPERATION.
- INSPECT EQUIPMENT FOR UNUSUAL NOISES WHILE IN OPERATION.
- INSPECT ALL CONNECTIONS. REPLACE ALL LOOSE, WORN OR BROKEN BOLTS.
- INSPECT WHEEL LUG NUTS AND TORQUE TO 400 FT/LBS.

AFTER SEASON CHECKLIST

- CLEAN OUT ALL ACCUMULATED GRAIN FROM BOX AND AUGER ASSY.
- LEAVE AUGER INTAKE AND CLEAN-OUT DOORS IN OPEN POSITION DURING STORAGE TO PREVENT MOISTURE ACCUMULATION.
- CLEAN OFF ALL ACCUMULATION OF DIRT AND CHAFF TO PREVENT MOISTURE RETENTION AND RUST.
- REPAINT ALL AREAS WHERE PAINT HAS CHIPPED OR WORN OFF.
- ALWAYS STORE WITH AUGER IN DOWN POSITION.

90176

! WARNING

TOW ONLY WITH FARM TRACTOR

90244

P# 90176

P# 90244

Decals



! WARNING

HYDRAULIC SYSTEM CONTAINS HOT OIL UNDER PRESSURE WHICH CAN PENETRATE SKIN CAUSING SERIOUS INJURY, BURNS OR ILLNESS.

IF HYDRAULIC FLUID COMES IN CONTACT WITH SKIN, WASH THE CONTAMINATED AREA WITH SOAP & WATER. CONSULT A PHYSICIAN IMMEDIATELY IF SKIN HAS BEEN PENETRATED.

ALWAYS KEEP FITTINGS TIGHT AND REPLACE ANY WORN OR DAMAGED HOSES. RELEASE PRESSURE AND ALLOW OIL TO COOL BEFORE LOOSENING FITTINGS.

90172

P# 90172



! WARNING

KEEP HANDS CLEAR

ENTANGLEMENT IN ROTATING AUGER CAN CAUSE SERIOUS INJURY!

ALWAYS SHUT OFF POWER BEFORE ATTEMPTING TO SERVICE AUGER.

90174

P# 90174

! WARNING

WINDOWS PROVIDE A LIMITED VIEW OF PERSONS OR TRAFFIC APPROACHING FROM THE REAR OF AUGER CART.

BE ABSOLUTELY SURE OF WHAT IS BEHIND BEFORE TURNING STOPPING OR BACKING.

90242

P# 90242

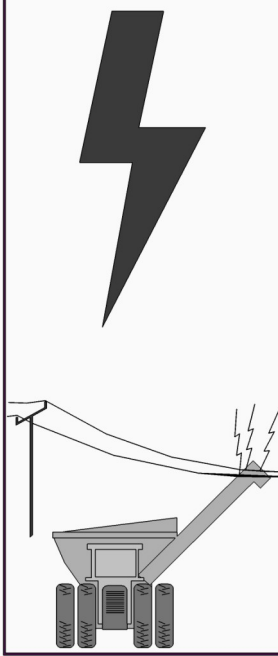

! WARNING

UNLAWFUL TO OPERATE THIS EQUIPMENT WITHIN TEN FEET OF OVERHEAD HIGH-VOLTAGE LINES.

Contact with power lines can result in death or serious burns.

SERIOUS INJURY OR DEATH FROM ELECTROCUTION MAY RESULT.

ALWAYS KEEP AUGER IN TRANSPORT (DOWN) POSITION WHEN NOT IN USE.

DO NOT ATTEMPT TO FREE POWER LINES. CONTACT YOUR POWER COMPANY. STAY AWAY FROM AUGER AND ALL ATTACHED EQUIPMENT.

90173

P# 90173

Decals

PATENT
UNITED STATES
PATENT NUMBER
6,488,114
6,776,569

82904

P# 82904

CLOSED -

85026

P# 85026

OPEN -

90323

P# 90323

Decals

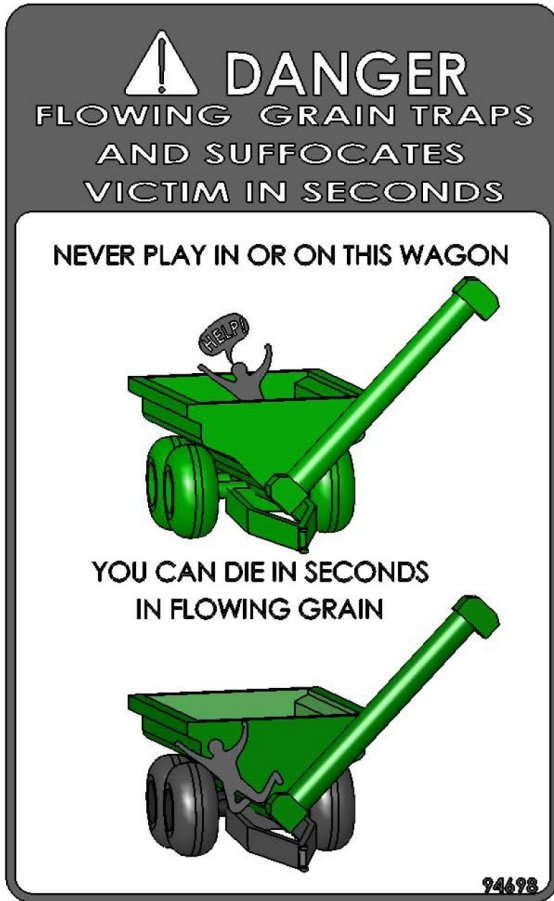

P# 94698



P# 12484



P# 94699

Safety





Tractor Requirements

- Tractor Hp Min. = 220 Hp Four Wheel Drive
- Tractor Hp Max. = N/A
- Tractor Hp PTO Min. = 200Hp
- Tractor Hp PTO Max. =N/A
- Tractor PTO RPM = 1000 RPM
- Draw Bar Load Min. = 10,000 Lbs (CAT-3)
- Draw Bar Clevis = 2" Pin
- PTO/Draw Bar Clevis Pin = 20"
- Draw Bar / Ground Height = 18" - 22"
- Tractor Hydraulic Flow = 1-5 GPM Max.
- Tractor Hydraulic PSI = 2300 - 3000 PSI Max.
- Hydraulic Outlets = 3Min. - 5 Max.
- Hydraulic Zero Pressure Return Outlet = Up to 1
- 7-Flat Pin Electric Tractor Connection
- Rear Hitch Category = N/A

Pre Operation Check

- Make sure safety shields are in place.
- Make sure there is no frozen material to obstruct the grain doors or augers.
- Make sure tractor draw bar matches standards shown in draw bar adjustment diagram.

HOSE COLOR MARKINGS

RED - Brake cylinders

YELLOW - Steering

BLUE - Grain Doors

BLUE/RED - Swivel Auger Control

ORANGE - Auger Folding

NO COLOR - Clutch

1000 RPM 1 3/4 - 20 (20")

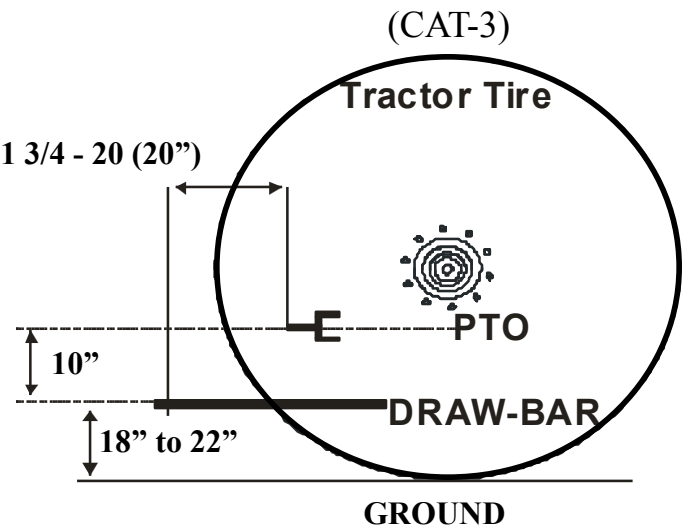

Required Draw-Bar Adjustment



Attaching to Tractor

- Attach tractor draw bar to grain cart hitch with properly sized hitch pin that has a retainer device.
- Attach safety chain to tractor.
- Crank trailer jack to slowly place pressure on draw bar. Move jack to storage location and secure.
- Check that the tractor's PTO has proper size splines.
- Check that PTO slides freely and is not damaged.
- Attach PTO shaft to tractor securely as required by its locking mechanism. PTO should have approximately 1/3 over-lap.
- Attach hydraulic lines making sure the connectors are clean and in good repair. See hose color code list above.



Initial Start Up

- **Never operate** this machine if shields are missing or if persons are in or on this machine.
- Do not leave tractor seat.
- Keep everyone away while operating this machine.
- Operate all hydraulic controls to become familiar with the function of each tractor lever and to visually see that the unit is responding correctly.
- **Engage PTO SLOWLY** with tractor throttle at slow idle. Use maximum modulation on tractor PTO control.
- **Watch and listen** to confirm that the Grain Cart is operating properly. Run at fast idle for 5 minutes disengage PTO and shut off tractor engine and remove keys from ignition. Make all adjustments before any further operating is attempted.



NOTE

Make mental and/or physical notes concerning which way to move the lever to get the desired result.

In Field Procedure

- **Always close** grain doors before disengaging PTO.
- **Always engage** PTO before opening grain doors.
- Be sure grain doors are closed before loading.
- **Always engage** steering lock-out cylinders before attempting to back up this Grain Cart.
- **Always engage** steering lock-out cylinders when driving down roads.
- **Always disengage** steering lock-out cylinders when working in the field.
- **Always load** Grain Cart evenly front to back to avoid excessive tongue weight.



WARNING

Torque lug nuts to 420 ft/lbs. Tighten lug nuts before each day's use for the first 5 days.

Tandem Axle Frame

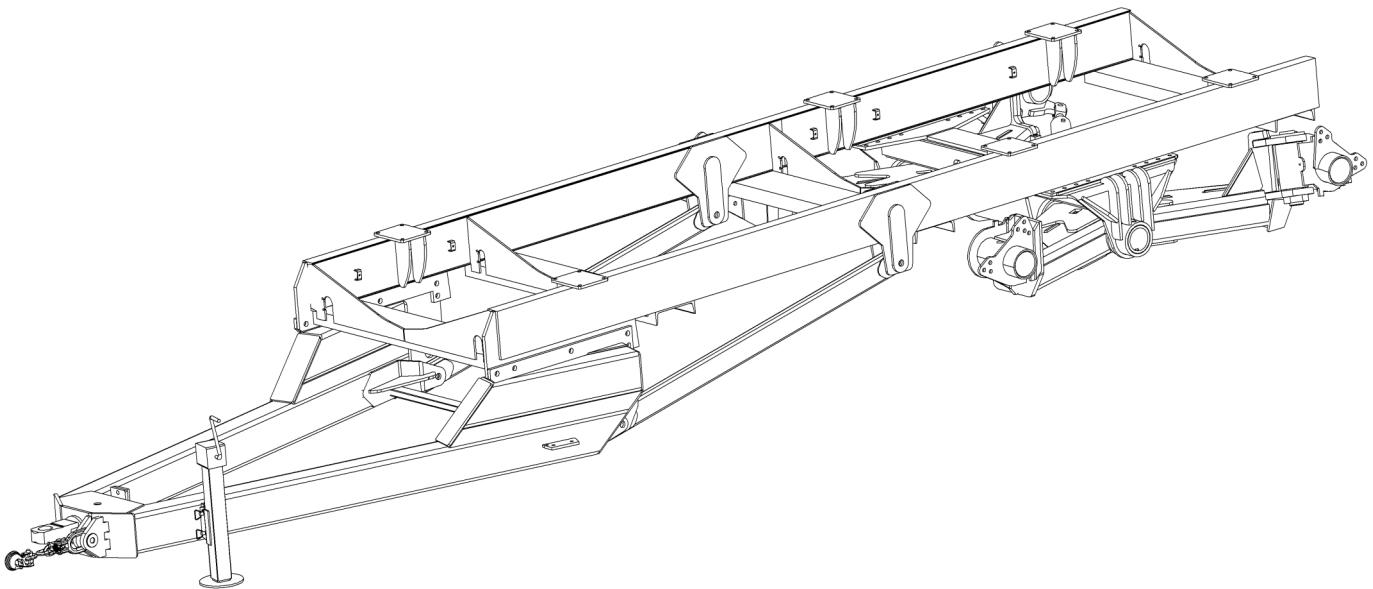

Tandem Auto Steering System

The steering cylinders have two internal functions.

First, moving the tractor hydraulic lever to the “**Float Position**” allows the unit to steer. This is accomplished by hydraulic hoses connected to each cylinder. When the unit is turning, oil is forced out of one cylinder and into the other cylinder. This requires that there is no air in the hydraulic hoses or cylinders to function correctly.

The second function is used for backing up. Move tractor hydraulic lever to engage the cylinder. This will force the cylinder to align the steering to the “Center” or straight position.

If oil is lost or air enters into the system, it must be bled. See “**Bleeding Instructions for Tandem Auto Steering**” or “**Bleeding Instructions for Bleeding Tridem Auto Steering**” to correct the issue.

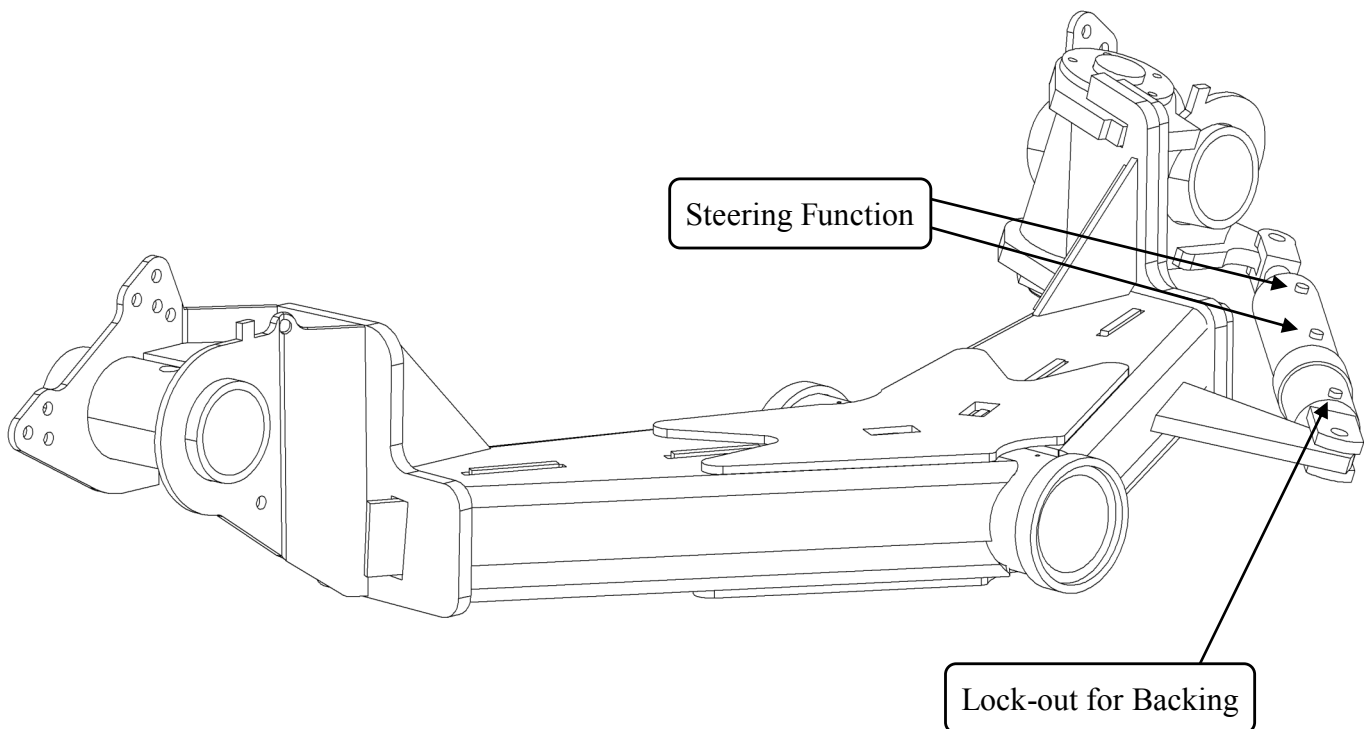

Bleeding Instructions for Tandem Auto Steering System



WARNING

Do not remove hydraulic fitting from the (“C” port) until all pressure has been relieved from the hydraulic line from the tractor (YELLOW marked hose).

Balzer recommends the following bleeding procedure: (see illustration “Tandem Auto Steering Schematic”)

1. Attach jumper hose #72182 to (“C” port) and (“B” port).
2. Pressurize hydraulic line from tractor (YELLOW marked hose).
3. Open ball valve to (“B” port).
4. Open the (“D” port) bleeder screw on each cylinder one at a time until no air bubbles come out. Then close bleeder screw. (Cylinder will stroke out)
5. Open the (“E” port) bleeder screw on each cylinder one at a time until no air bubbles come out. Then close bleeder screw.
6. Close ball valve to (“B” port).
7. Move jumper hose #72182 from (“B” port) to (“A” port).
8. Open ball valve to (“A” port).
9. Open the (“E” port) bleeder screw on each cylinder one at a time until no air bubbles come out. Then close bleeder screw.
10. Open the (“D” port) bleeder screw on each cylinder one at a time until no air bubbles come out. Then close bleeder screw. (Cylinder will stroke in)
11. Close ball valve (“A” port).
12. Move jumper hose #72182 from (“A” port) to (“B” port).
13. Open ball valve to (“B” port).
14. Open the (“D” port) bleeder screw on each cylinder one at a time until no air bubbles come out. Then close bleeder screw.
15. Close ball valve to (“B” port).
16. Relieve all pressure from the hydraulic line from the tractor (YELLOW marked hose).
17. Remove jumper hose #72182 from (“C” port) and (“B” port).

Air bleeding is complete.

Tandem Auto Steering System Schematic

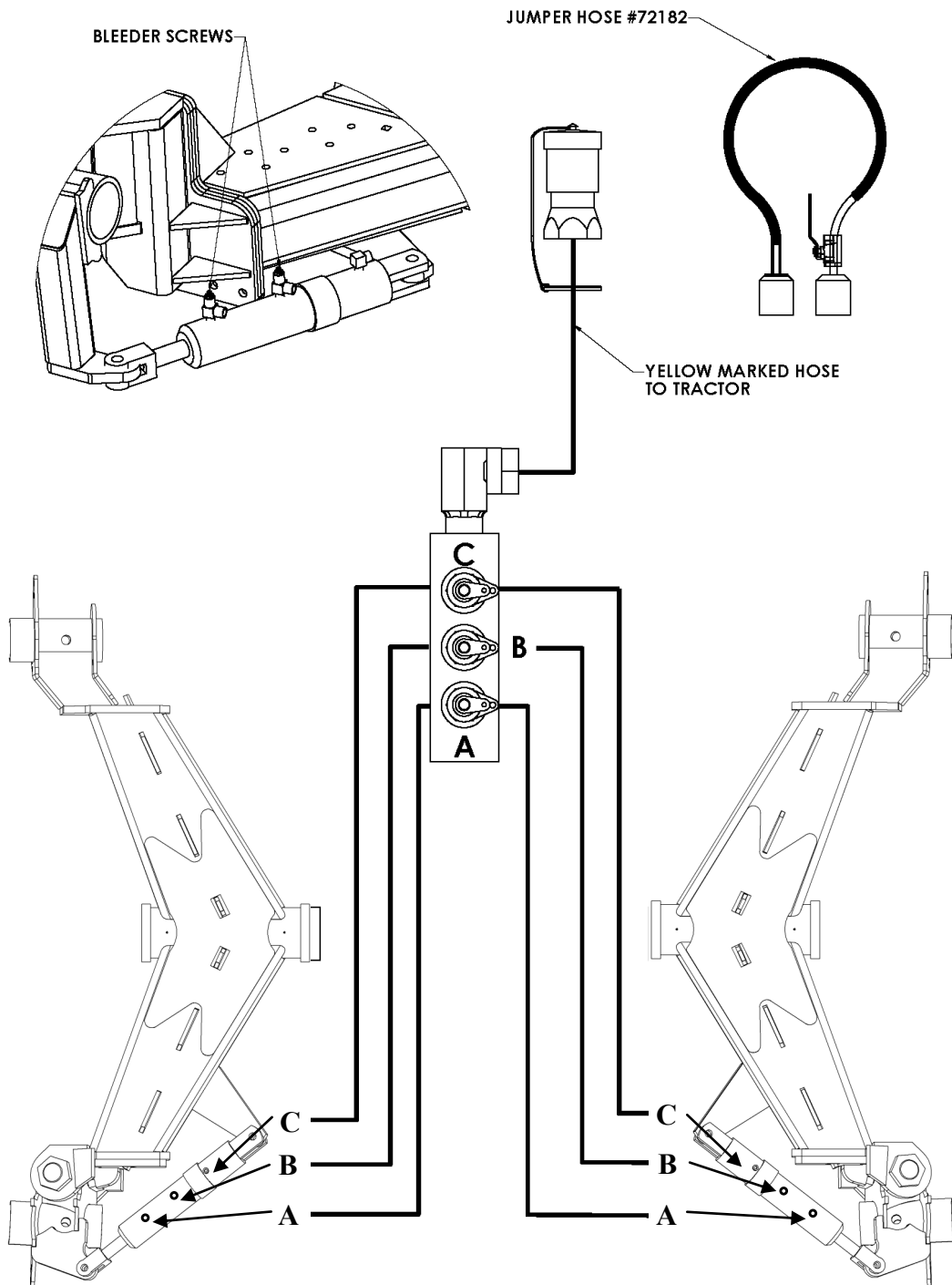

Tridem Axle Frame

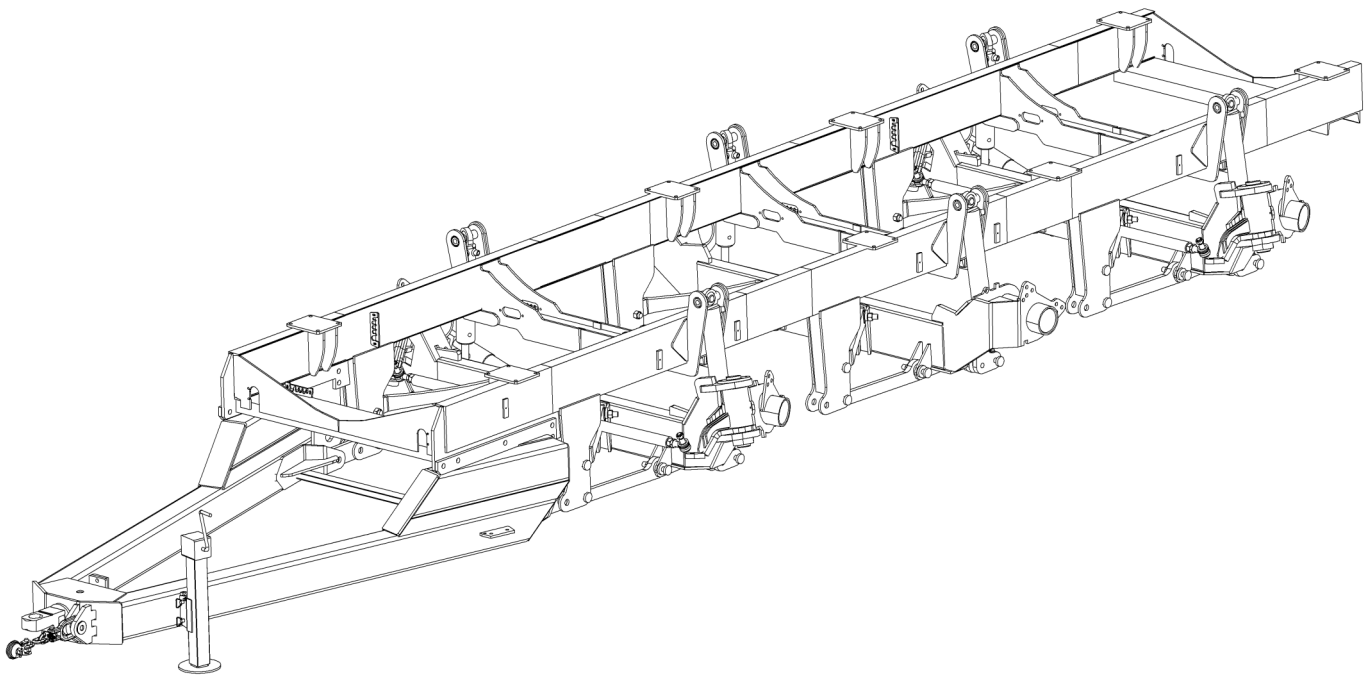

Tridem Auto Steering

Common Information

This system consists of three axles which are suspended from the unit frame by hydraulic cylinders. Each axle uses two hydraulic cylinders, one located at each outer end of the axle. These hydraulic cylinders transmit the tank load to the axles. The axles are attached to the unit frame by four parallel links, two at each outer end of each axle. The parallel links stabilize the axle, they do not carry any weight.

Suspension Hydraulics

Each side of the unit uses three hydraulic cylinders. On each side of the unit, the three hydraulic cylinders are connected together by hydraulic hose. Hydraulic oil can only move between the hydraulic cylinders of one side, the right side of the unit is independent of the left side of the unit. This system allows the hydraulic oil to move from one suspension cylinder to the other two suspension evenly, in order not to overload any of the axles. This would occur as the tire on that axle was lifted or lowered by a bump or hole in its path.

Suspension Limits

Care must be taken to travel where the suspension will not be pushed beyond its limits. The suspension cylinders will allow a single tire to travel over a 7" tall bump and through a 7" deep hole. If these limits are exceeded, damage to the suspension will occur. This is very important not only to prevent damage, but to promote safe operation.

Suspension Height Adjustment

The front cylinder on each side of the unit has a ball valve and auxiliary hydraulic hose. The ball valves lock the hydraulic oil within the three cylinders on each side during normal operation. The suspension cylinder at the **second axle** must be extended 7". Adjust the suspension cylinder only when the unit is empty or not loaded. Connect the auxiliary hydraulic hose to a hydraulic source that can provide a **minimum of 2500 PSI**. After the connection has been made the ball valve can be opened and oil added to extend the suspension cylinder to the 7" **measurement**. Close the ball valve and disconnect from the hydraulic source. This procedure is the same for both sides of the unit.

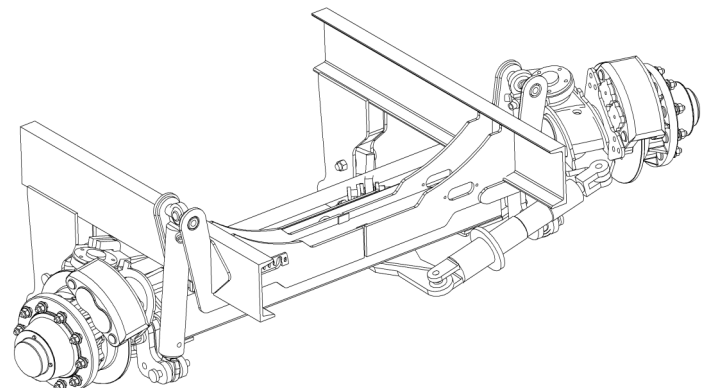

Tridem Auto Steering Schematic

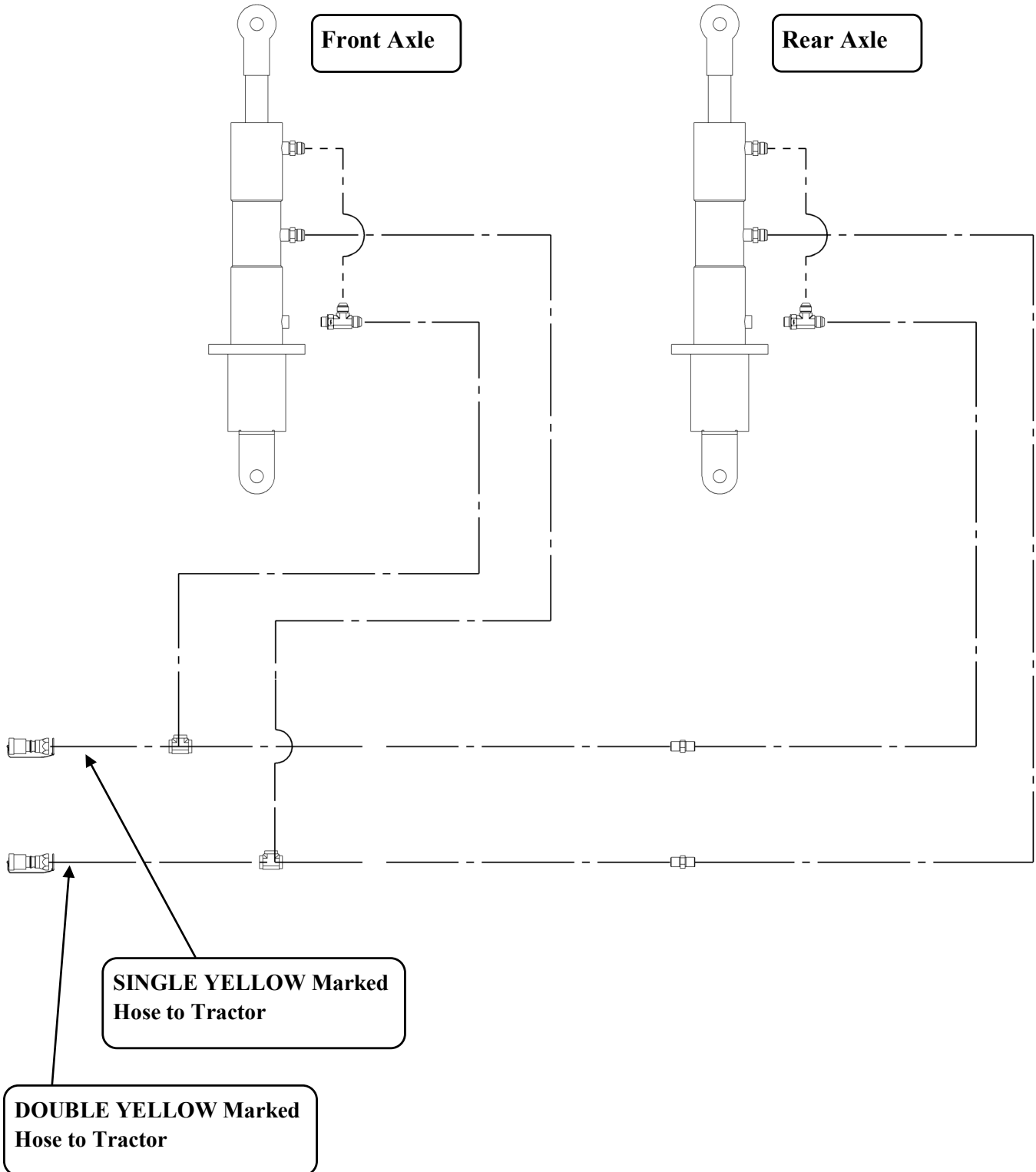

Tandem Suspension Toe In

The toe on all steering axles should be adjusted to maintain 1/8 inch toe-in on the steering axle. The cylinder steering rod end is threaded to the clevis for adjustment. Raise frame at steering axle until wheel is off the ground. Measure the distance between front edges of rims and rear edges of the rims. Adjust cylinder steering rod end to achieve 1/8 inch shorter distance between front rim edges when compared to the rear measurement. The distance can also be measured to the frame rail by adjusting to achieve 1/16 inch toe-in on the front edge of rim to frame rail on both sides.

Measure at center of rim.

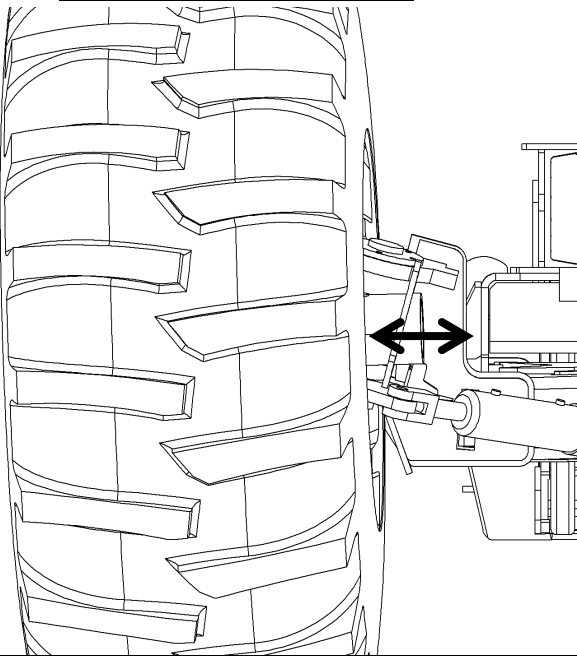

Distance measured between left and right rims should be adjusted to 1/8" shorter to the front.

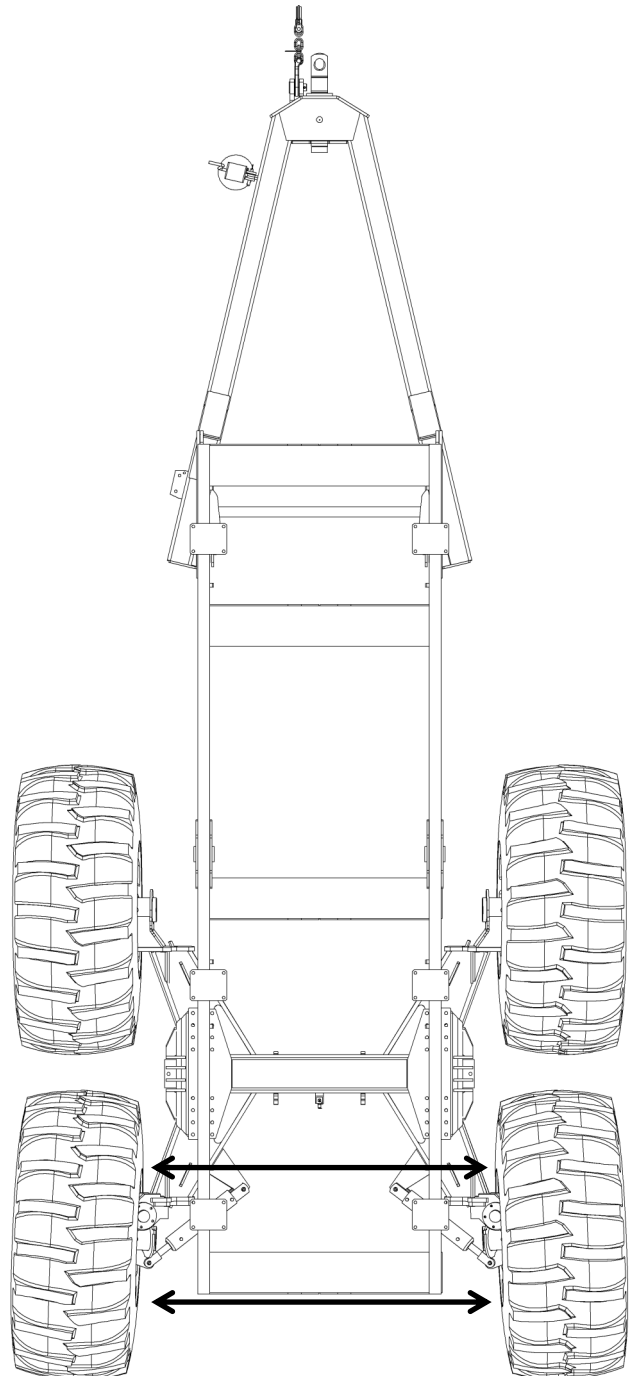

Distance measured from rim to frame rail should be adjusted to 1/16" shorter in front on both sides.

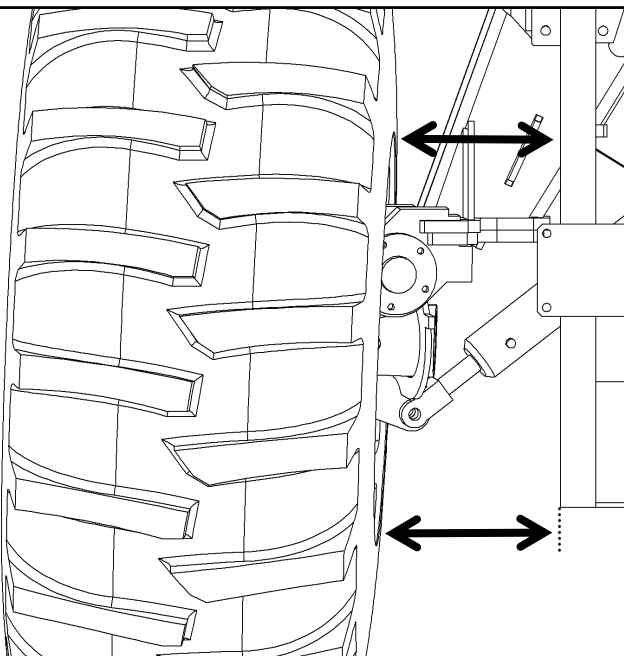

Tridem Suspension Toe In

The steering cylinder rod end is threaded to the clevis for adjustment. First, raise steering axle until wheels are off the ground. Measure the distance on the passenger side of frame from the front of the rim to the frame and then from the rear of the rim to the frame. The toe in should be $1/16''$ shorter in the front of the rim. To adjust this distance, the steering cylinder has a threaded rod. Loosen the clamp bolt on the clevis and turn the cylinder rod in or out to adjust the toe in on the passenger side. When toe is set on the passenger side, check drivers side. If the drivers side needs adjustment, loosen the jam nuts on the tie rod. Rotate rod to the proper setting for the drivers side. Re-check both sides to make sure they are still correct. If they measurements are still correct, tighten the jam nuts on the tie rod and the clamp bolt on the steering cylinder.

Distance measured between left and right rims should be adjusted to $1/8''$ shorter to the front.

Measure at center of rim.

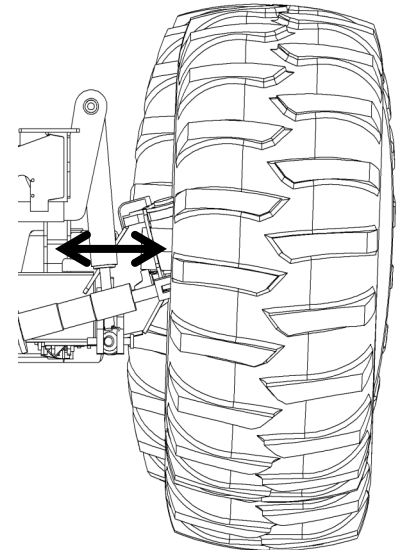
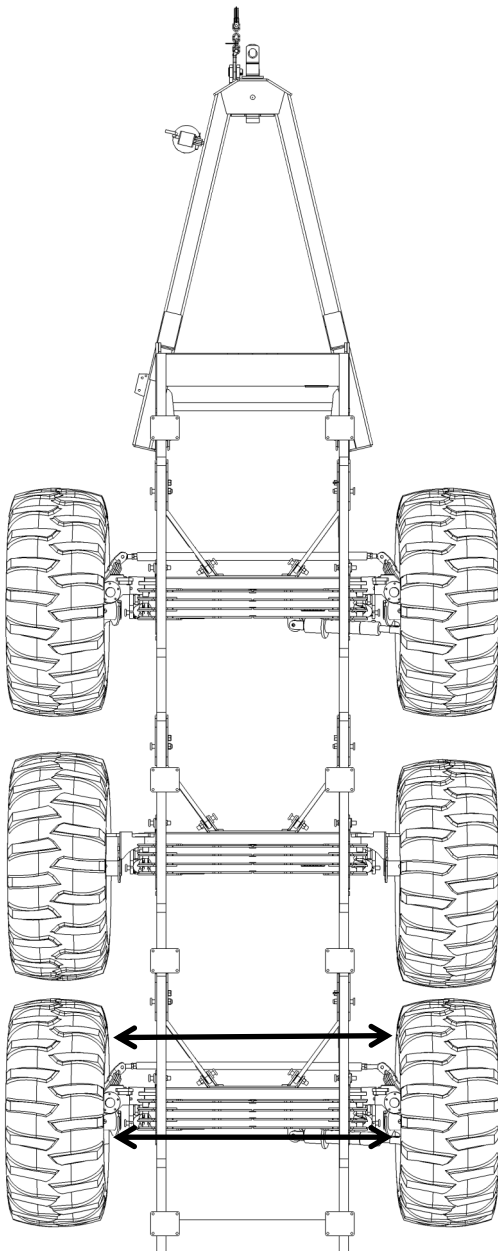

Distance measured from rim to frame rail should be adjusted to $1/16''$ shorter in front on both sides.

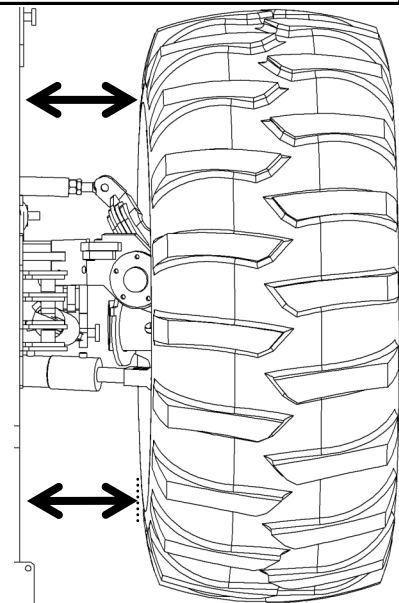

Braking System

Pressure Releasing Spring

Some tractors hydraulic systems keep a small amount of pressure in the hydraulic lines even when the control lever is set to “float” position. A pressure releasing spring is used to counteract the hydraulic pressure coming from the tractor.

Brake Operation

Tractors with “closed center or open center” hydraulic circuit.

1. To apply the brakes, the lever must be pulled fully backward.
2. To release the brakes, the lever must be pushed fully forward to the “float position”.

Inspection Of Braking Fluid Level

If the spring is compressed down to 8” or less when braking, add hydraulic fluid as per “**Fill Instructions for Master Cylinder**”.

Fill Instructions for Master Cylinder

The master cylinder of the braking system is designed to create a vacuum in the hydraulic lines leading to the calipers. When the brakes are fully released, the vacuum created pulls the piston of the calipers to fully retract, which disengages the brakes on the unit. To do so, the master cylinder must never be full of hydraulic fluid when braking.

1. Attach jumper hose #72182 to (“A” port) and (“B” port).
2. Connect the hydraulic hoses to the tractor (RED marked hoses).
3. Open ball valve to (“A” port).
4. Apply and hold pressure to braking system from tractor hydraulics.
5. Relieve all pressure from the hydraulic lines from the tractor for the braking system (RED marked hoses).
6. Close Ball Valve to (“A” port).
7. Remove jumper hose #72182 from (“A” port) and (“B” port).
8. Apply and hold pressure to braking system.
9. Open bleeder screw on any brake caliper.
(This will allow the master cylinder spring to compress down to 14” long.
10. When the master cylinder has compressed down to 14” long, tighten bleeder screw.

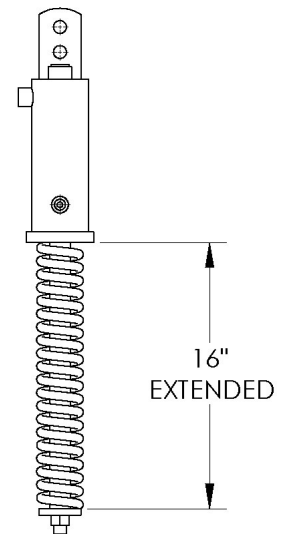

When the master is fully extended, the pressure release spring measures roughly 16” long.

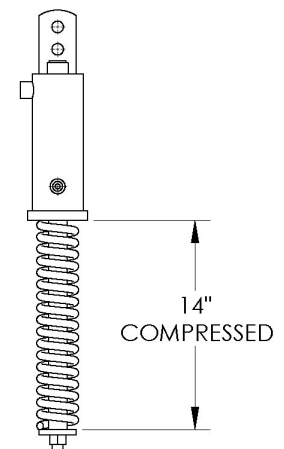

When adding braking fluid to the master cylinder for the last time, the pressure releasing spring must be held compressed at 14” long.

Braking System

How To Bleed The Wheel Brakes

1. Attach jumper hose #72182 to (“A” port) and (“B” port).
2. Connect the hydraulic hoses to the tractor (**RED marked hoses**).
3. Apply and hold pressure to braking system from tractor hydraulics.
4. Open ball valve to (“A” port).
5. Loosen bleeder screw on brake caliper of closest wheel to tractor first, until no air bubbles come out.
6. Repeat procedure until all brakes are bled.
7. Relieve all pressure from the hydraulic lines from the tractor for the braking system (**RED marked hoses**).
8. Close Ball Valve to (“A” port).
9. Remove jumper hose #72182 from (“A” port) and (“B” port).
10. Apply and hold pressure to braking system.
11. Open bleeder screw on any brake caliper.
(This will allow the master cylinder spring to compress down to 14” long.)
12. When the master cylinder has compressed down to 14” long, tighten bleeder screw.

Braking System Schematic

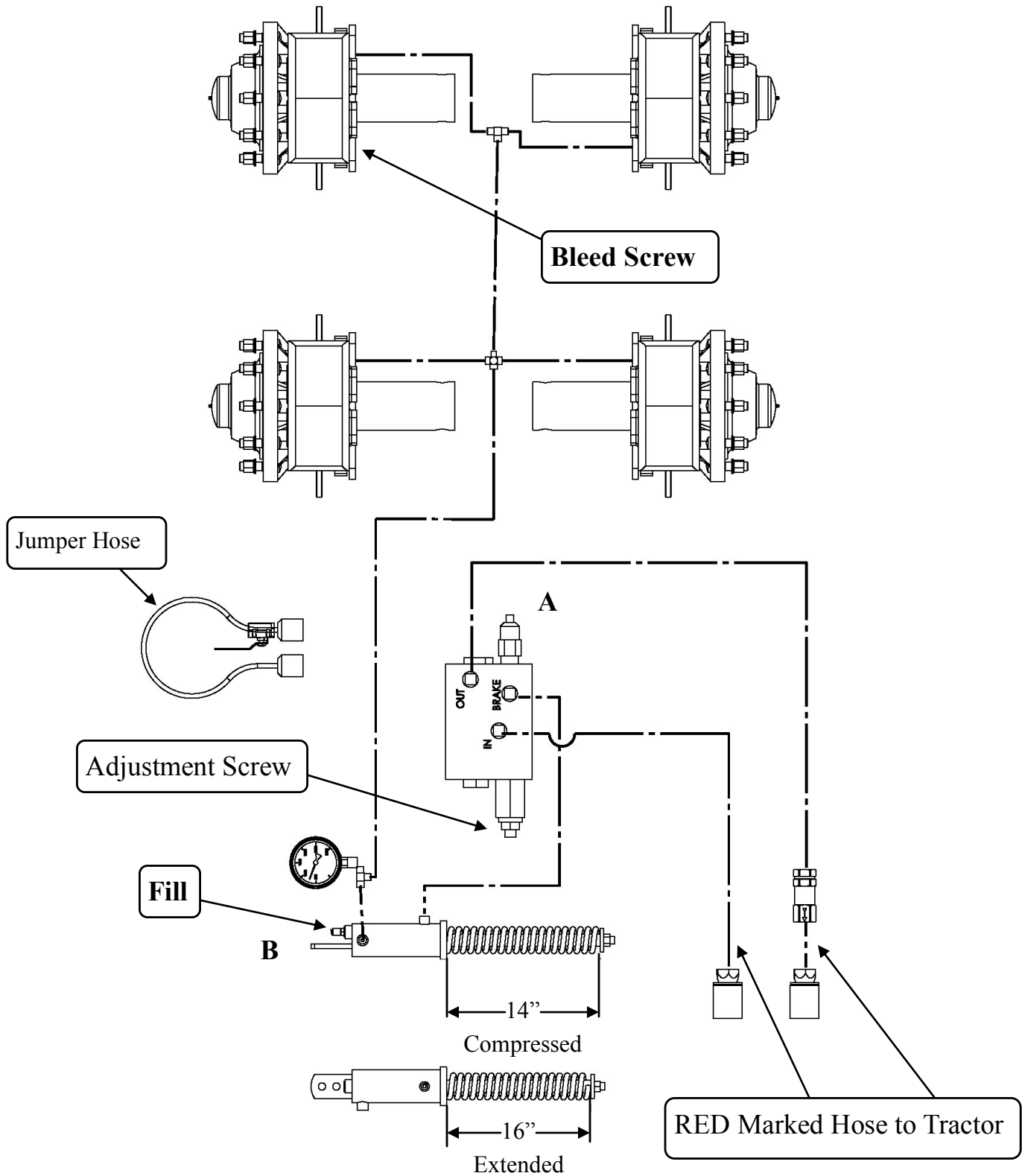

PTO / Jack

PTO

The PTO has 1 3/4—20 tractor ends and 1 3/4—20 implement ends. The implement end provides a friction clutch or cut-out clutch that protects the gear box and drive-line from overload. The PTO must be engaged slowly, use max modulation on tractor. **Do not slam engage!**



Never operate without PTO Guards!

Jack Storage

The jack storage location is pictured below. This location keeps it out of the way of the tires and removes the possibility of dragging.

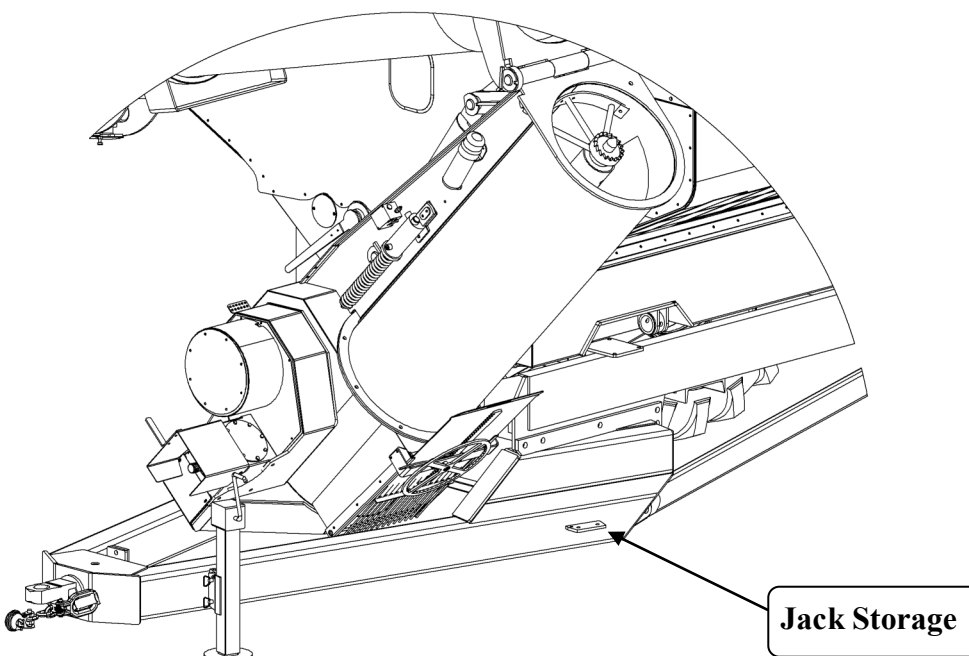

Cleanout Doors

These doors are available for cleanout when needed.

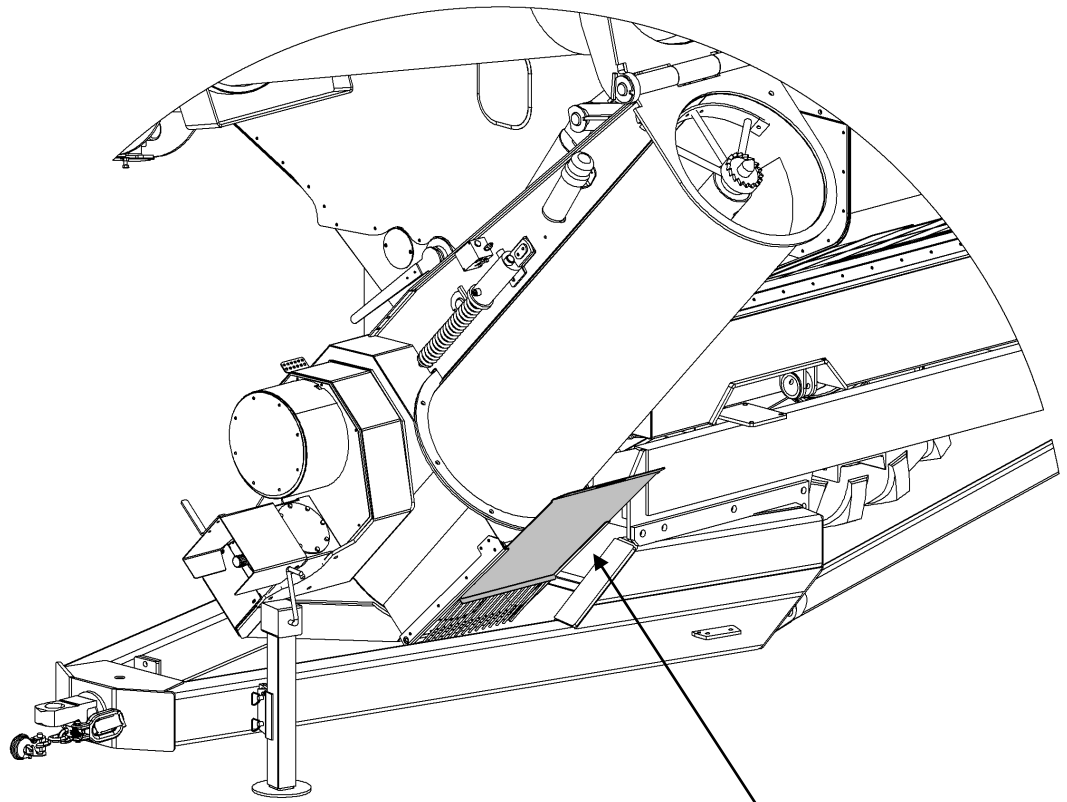

Bottom Cleanout Door

Front Cleanout Door

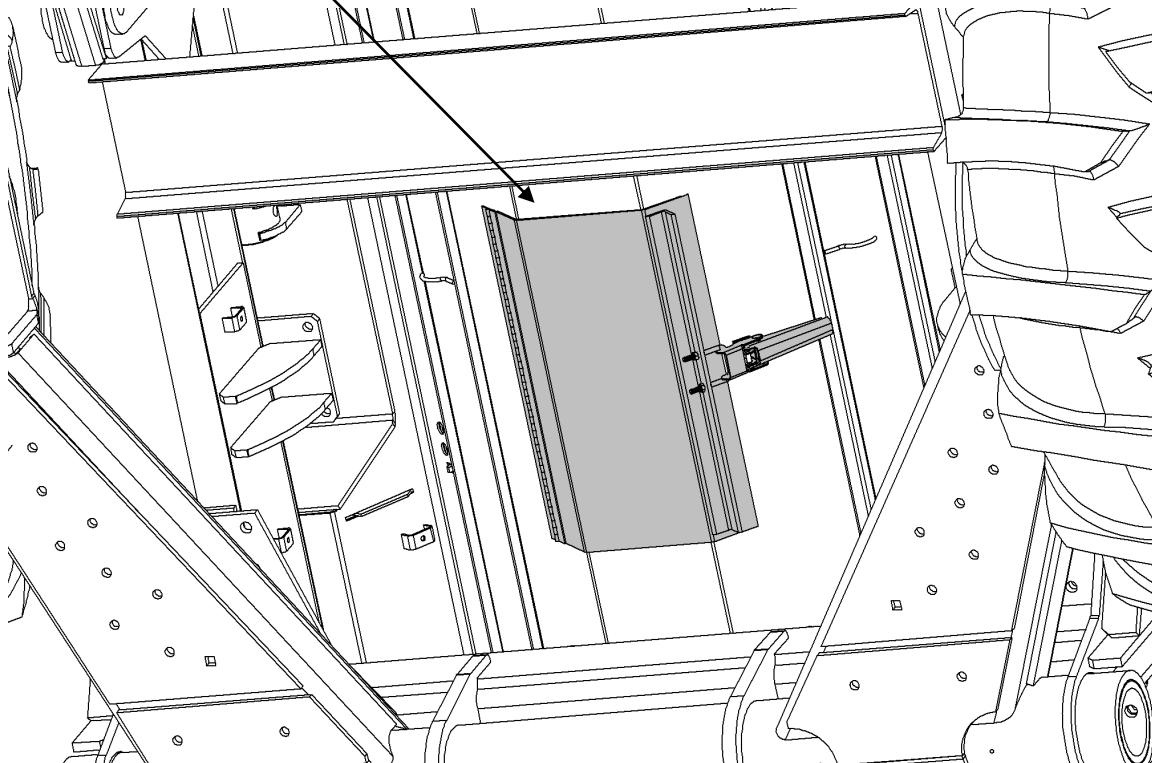

Operation

Grain Doors Hydraulic Control

These doors are the primary means of starting, stopping and regulating grain flow to the horizontal auger. For most common grains, the doors do not need to be completely open for full capacity discharge.



Keep all shields in place at all times!

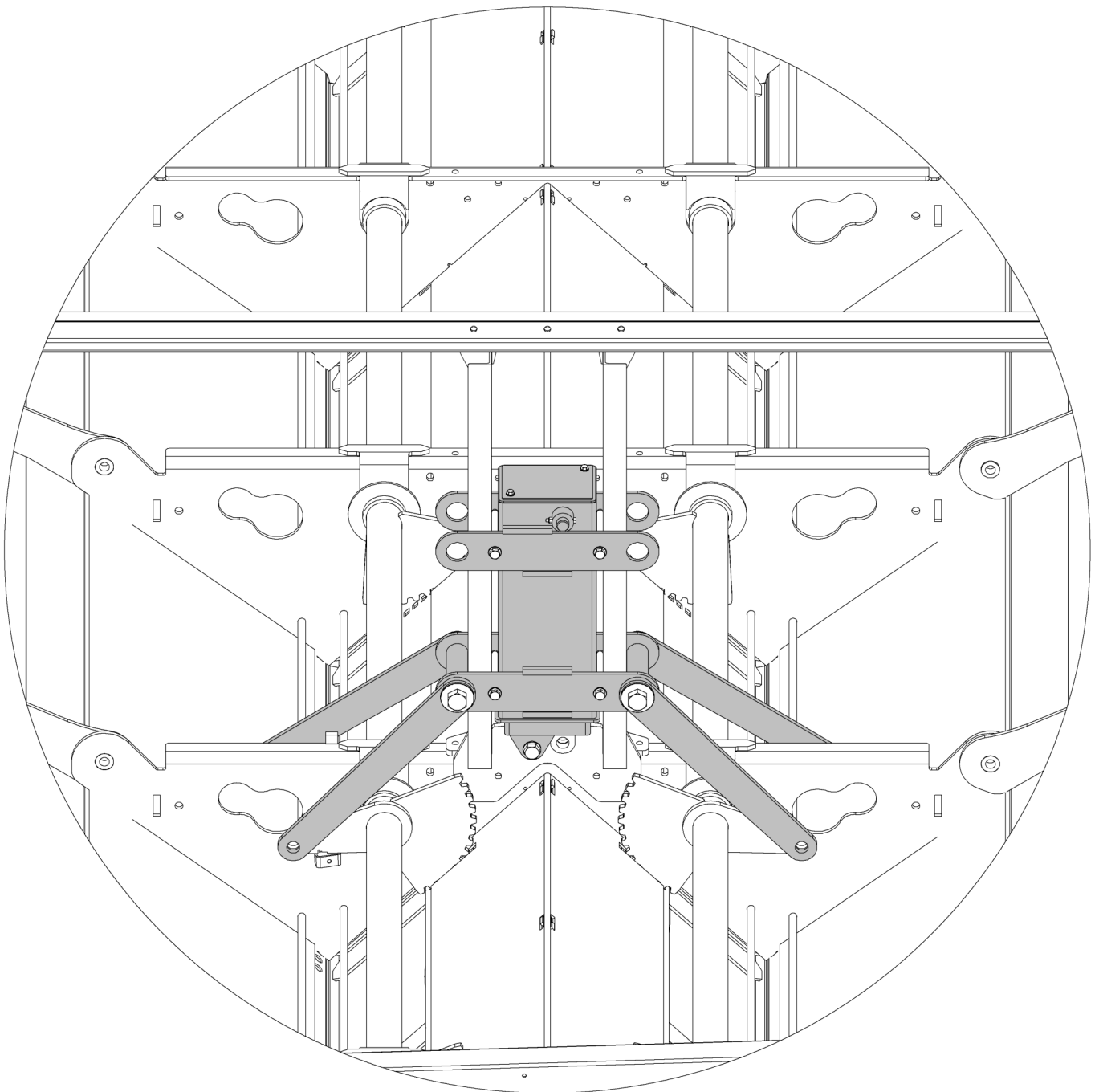

Vertical Auger

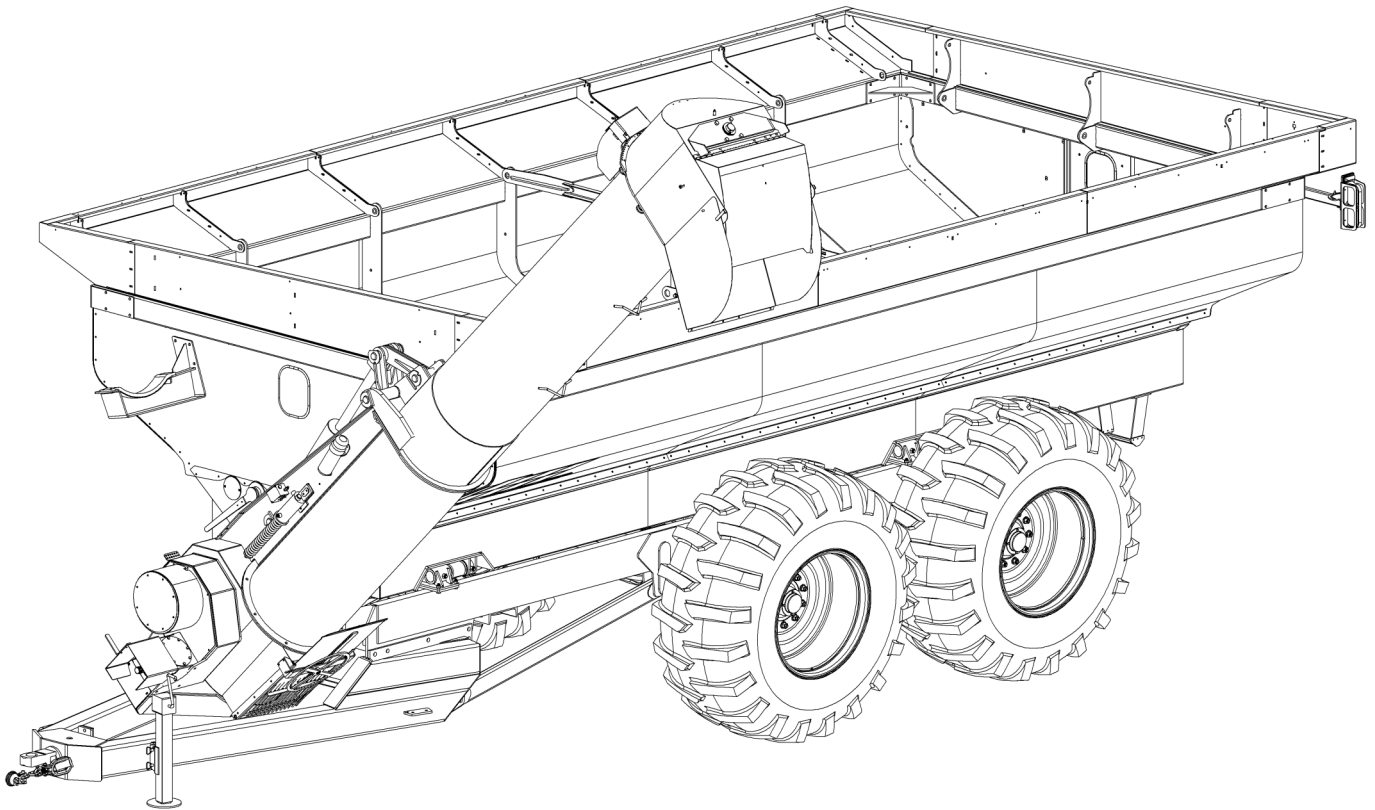

CAUTION

Never transport with vertical auger in unloading position. Doing so may cause structural damage to the vertical auger and grain cart.

Instructions for Unloading Grain Cart on a Non-Swivel Upper Vertical Auger



NOTE

Visually become aware of which hydraulic levers control each of the functions on the grain cart.



CAUTION

Never transport with vertical auger in unloading position. Doing so may cause structural damage to the vertical auger and grain cart.

1. Engage tractor hydraulic lever to un-fold upper auger until upper auger locks into place. (**ORANGE marked hose**)
2. Start PTO slowly and use maximum modulation on tractor control.
3. Allow PTO to get up to speed.
4. Engage tractor hydraulic lever that controls the clutch.
5. **Slowly** engage tractor hydraulic lever that opens grain doors. (**BLUE marked hose**)
6. To control the amount of grain coming out of the auger, engage tractor hydraulic lever that controls the doors opening and closing motion.
7. When unloading is complete, engage tractor hydraulic lever that closes grain doors. (**BLUE marked hose**)
8. Disengage tractor hydraulic lever that controls the clutch.
9. Allow PTO to run for 3 to 5 seconds to clean out the vertical auger.
10. Disengage PTO.



CAUTION

Do not disengage PTO before clutch has been shut off. This may plug auger with too much grain and you will not be able to restart auger.

11. Engage tractor hydraulic lever to fold upper auger down in to saddle. (ORANGE marked hose)
12. Then reload grain cart.



WARNING

Failure to relieve pressure on horizontal auger clutch prior to shutting down the tractor can cause a failure of the swivel fitting. Trapped oil in the clutch circuit can expand due to warm temperatures, causing the swivel fitting to fail.

Instructions for Unloading Grain Cart on a Swivel Upper Vertical Auger



NOTE

Visually become aware of which hydraulic levers control each of the functions on the grain cart.



CAUTION

Never transport with vertical auger in unloading position. Doing so may cause structural damage to the vertical auger and grain cart.

1. Engage tractor hydraulic lever to pressurize control valve body. (**BLUE and RED marked hose**)
2. Check if **RED** light on joystick is illuminated.



NOTE

The **RED** light comes on only when it is safe to fold the upper auger up or down. The upper auger will not move until **RED** light on joystick is illuminated.)

3. If **RED** light is not illuminated, rotate swivel head forward or backward till **RED** light comes on.
4. Engage tractor hydraulic lever to un-fold upper auger until upper auger locks in place. (**ORANGE marked hose**)
5. Start PTO slowly and use maximum modulation on tractor control.
6. Let PTO get up to speed.
7. Press the trigger on the joystick that controls the clutch. Horizontal auger will engage. (**GREEN light on the joystick will be illuminated**)
8. Press the button on the top of the joystick that opens the grain doors. (**Open slowly**)
9. Press the buttons on the top of the joystick that open and close the grain doors to control the amount of grain coming out.
10. When done unloading, press the button on the top of the joystick that closes the grain doors.
11. Press the trigger on the joystick that controls the clutch. Horizontal auger will disengage. (**GREEN light on the joystick will go off**)
12. Allow PTO to run for 3 to 5 seconds to clean out the vertical auger.
13. Disengage PTO.



CAUTION

Do not disengage PTO before clutch has been shut off. This may plug auger with too much grain and you will not be able to re-start auger.

14. Rotate swivel auger head till **RED** light is illuminated.
15. Engage tractor hydraulic lever to fold upper auger down into saddle. (**ORANGE marked hose**)
16. Reload grain cart.



WARNING

Failure to relieve pressure on horizontal auger clutch prior to shutting down the tractor can cause a failure of the swivel fitting. Trapped oil in the clutch circuit can expand due to warm temperatures, causing the swivel fitting to fail.

Running Light Extensions

The running lights on the grain cart are designed to comply with rules set for the width of the grain cart itself. When towing the grain cart with any vehicle wider than the cart itself, there are running light extensions available.

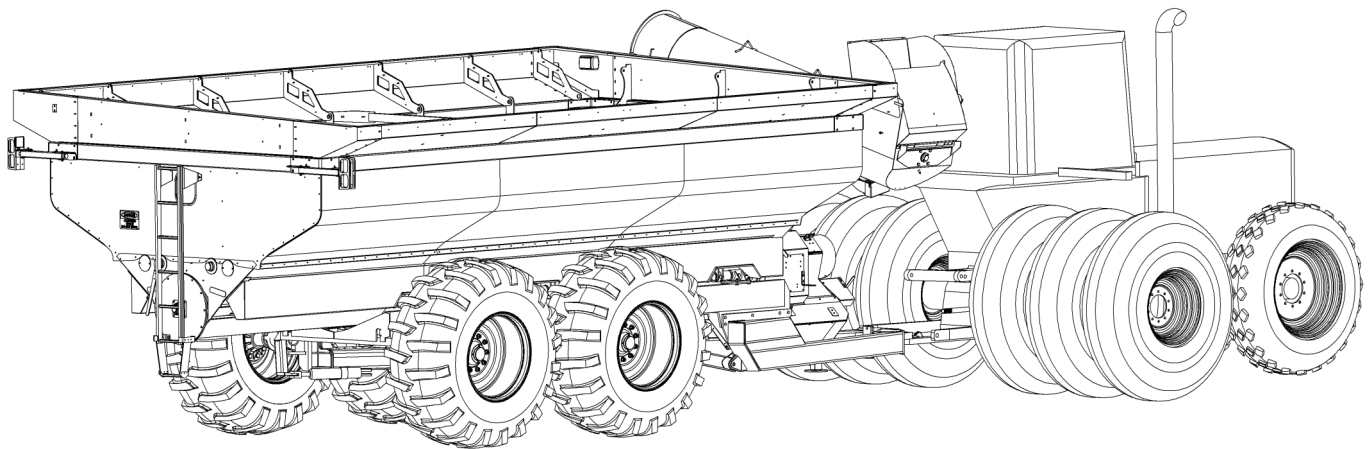



Model 640M Calibration

Included are the configuration codes for the Model 640M indicator for either six or eight weigh bar systems.

System Configuration	Units of Measure	Configuration Code #	Custom Code
6 weigh bar	lb	98390	57640
6 weigh bar	kg	98394	26140
8 weigh bar	lb	98390	74270
8 weigh bar	kg	98394	33690

Follow instructions below:

Model 640M Numeric Entry Procedure

Use the following procedure to enter numbers:

- RM Key Press to increment value
- M+ Key Press to decrement numeric value
- HOLD/MENU Press to move cursor one position to the right for numeric entry

Reference this section anytime it refers to Numeric Entry Procedure

EXAMPLE: How to Enter 640...

See steps A-E on how to enter 640

- A. Press on the RM key 7 times... 6 is displayed
- B. Press the HOLD/MENU key once... 6_ is displayed
- C. Press the RM key 5 times... 64 is displayed
- D. Press the HOLD/MENU key once... 64_ is displayed
- E. Press on the RM key once... 640 is displayed

Model 640M Calibration

Calibration Instructions for Model 640M Indicator (lb, 6 weigh bar)

The following calibration instructions are for setting up an Avery Weigh-Tronix Model 640M for weighing in Lb and a six weigh bar Balzer Grain Cart. If this procedure doesn't get results within 1% then field calibration must be performed.

- | | |
|-------------------------------------------------------------------------------------------|-------------------------------------------------------|
| 1. From the Gross Mode, press and hold the HOLD/MENU Key for three beeps, then release... | SET.PAS is displayed |
| 2. Use the Numeric Entry Procedure and enter in 640 | 640 is displayed |
| 3. Press the PRINT/SELECT key... | 640 is displayed
with all display annunciators lit |
| 4. Press the PRINT/SELECT key... | CONFIG is displayed |
| 5. Press the PRINT/SELECT key... | Current Configuration # is shown |
| 6. Use the Numeric Entry Procedure to enter the following Configuration Code: 098390 | 098390 is shown |
| 7. Press the PRINT/SELECT key... | CONFIG is shown |
| 8. Press the MENU key once... | CUSTOM is shown |
| 9. Press the PRINT/SELECT key... | Current Custom # is shown |
| 10. Use the Numeric Entry Procedure to enter the following custom code number: 057640 | 057640 is shown |
| 11. Press the PRINT/SELECT key... | CUSTOM is shown |
| 12. Press the G/N key twice, busy is shown | returns to Gross weighing mode |

Model 640M Calibration

Calibration Instructions for Model 640M Indicator (kg, 6 weigh bar)

The following calibration instructions are for setting up an Avery Weigh-Tronix Model 640M for weighing in Kg and a six weigh bar Balzer Grain Cart. If this procedure doesn't get results within 1% then field calibration must be performed.

- | | |
|-------------------------------------------------------------------------------------------|-------------------------------------------------------|
| 1. From the Gross Mode, press and hold the HOLD/MENU Key for three beeps, then release... | SET.PAS is displayed |
| 2. Use the Numeric Entry Procedure and enter in 640 | 640 is displayed |
| 3. Press the PRINT/SELECT key... | 640 is displayed
with all display annunciators lit |
| 4. Press the PRINT/SELECT key... | CONFIG is displayed |
| 5. Press the PRINT/SELECT key... | Current Configuration # is shown |
| 6. Use the Numeric Entry Procedure to enter the following Configuration Code: 098394 | 098394 is shown |
| 7. Press the PRINT/SELECT key... | CONFIG is shown |
| 8. Press the MENU key once... | CUSTOM is shown |
| 9. Press the PRINT/SELECT key... | Current Custom # is shown |
| 10. Use the Numeric Entry Procedure to enter the following Custom code number: 026140 | 026140 is shown |
| 11. Press the PRINT/SELECT key... | CUSTOM is shown |
| 12. Press the G/N key twice, busy is shown | returns to Gross weighing mode |



Model 640M Calibration

Calibration Instructions for Model 640M Indicator (lb, 8 weigh bar)

The following calibration instructions are for setting up an Avery Weigh-Tronix Model 640M for weighing in Lb and an eight weigh bar Balzer Grain Cart. If this procedure doesn't get results within 1% then field calibration must be performed.

- | | |
|-------------------------------------------------------------------------------------------|-------------------------------------------------------|
| 1. From the Gross Mode, press and hold the HOLD/MENU Key for three beeps, then release... | SET.PAS is displayed |
| 2. Use the Numeric Entry Procedure and enter in 640 | 640 is displayed |
| 3. Press the PRINT/SELECT key... | 640 is displayed
with all display annunciators lit |
| 4. Press the PRINT/SELECT key... | CONFIG is displayed |
| 5. Press the PRINT/SELECT key... | Current Configuration # is shown |
| 6. Use the Numeric Entry Procedure to enter the following Configuration Code: 098390 | 098390 is shown |
| 7. Press the PRINT/SELECT key... | CONFIG is shown |
| 8. Press the MENU key once... | CUSTOM is shown |
| 9. Press the PRINT/SELECT key... | Current Custom # is shown |
| 10. Use the Numeric Entry Procedure to enter the following custom code number: 074270 | 074270 is shown |
| 11. Press the PRINT/SELECT key... | CUSTOM is shown |
| 12. Press the G/N key twice, busy is shown | returns to Gross weighing mode |

Model 640M Calibration

Calibration Instructions for Model 640M Indicator (kg, 8 weigh bar)

The following calibration instructions are for setting up an Avery Weigh-Tronix Model 640M for weighing in Kg and an eight weigh bar Balzer Grain Cart. If this procedure doesn't get results within 1% then field calibration must be performed.

- | | |
|-------------------------------------------------------------------------------------------|-------------------------------------------------------|
| 1. From the Gross Mode, press and hold the HOLD/MENU Key for three beeps, then release... | SET.PAS is displayed |
| 2. Use the Numeric Entry Procedure and enter in 640 | 640 is displayed |
| 3. Press the PRINT/SELECT key... | 640 is displayed
with all display annunciators lit |
| 4. Press the PRINT/SELECT key... | CONFIG is displayed |
| 5. Press the PRINT/SELECT key... | Current Configuration # is shown |
| 6. Use the Numeric Entry Procedure to enter the following Configuration Code: 098394 | 098394 is shown |
| 7. Press the PRINT/SELECT key... | CONFIG is shown |
| 8. Press the MENU key once... | CUSTOM is shown |
| 9. Press the PRINT/SELECT key... | Current Custom # is shown |
| 10. Use the Numeric Entry Procedure to enter the following custom code number: 033690 | 033690 is shown |
| 11. Press the PRINT/SELECT key... | CUSTOM is shown |
| 12. Press the G/N key twice, busy is shown | returns to Gross weighing mode |



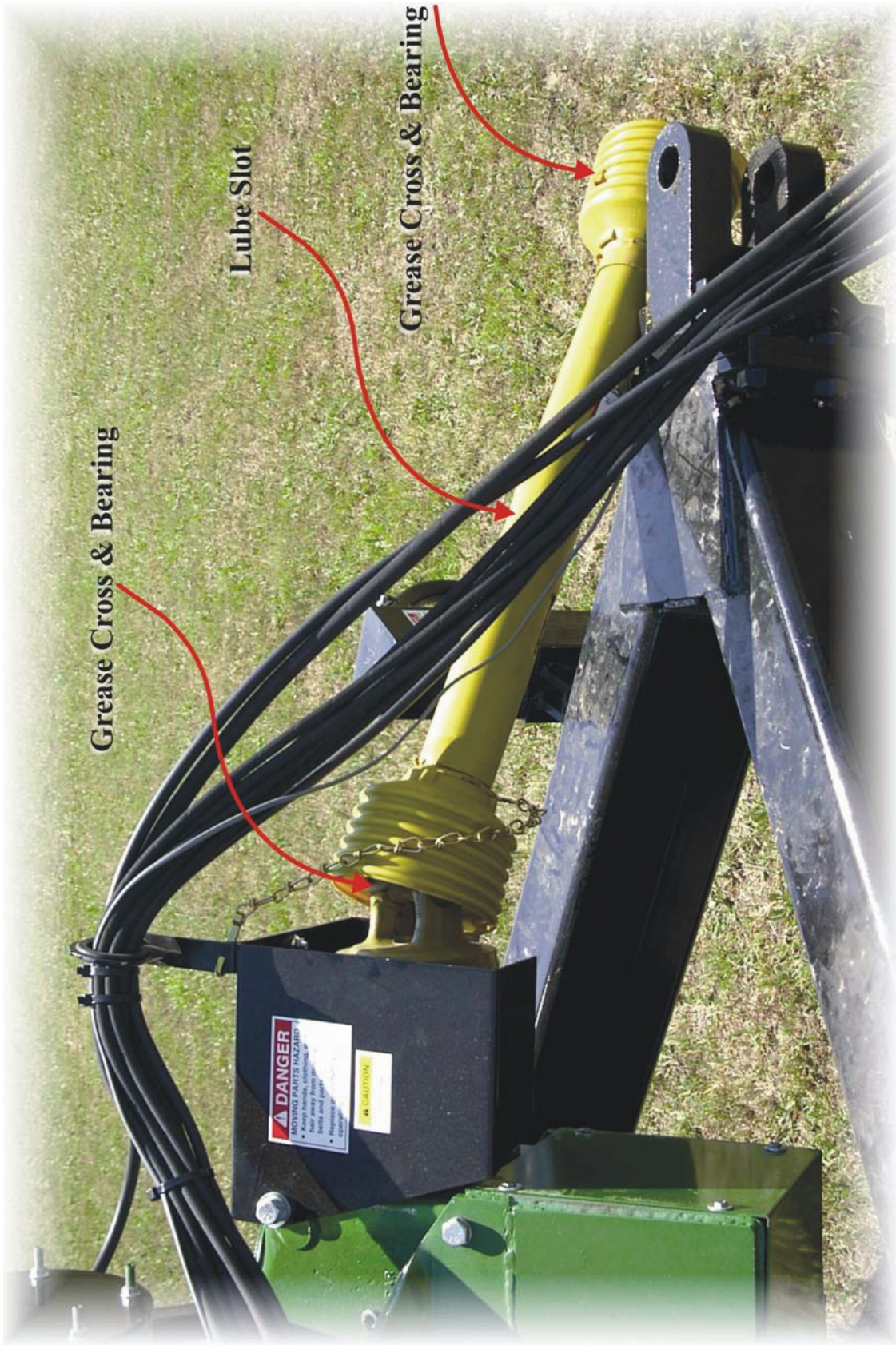

PTO Lubrication Specification

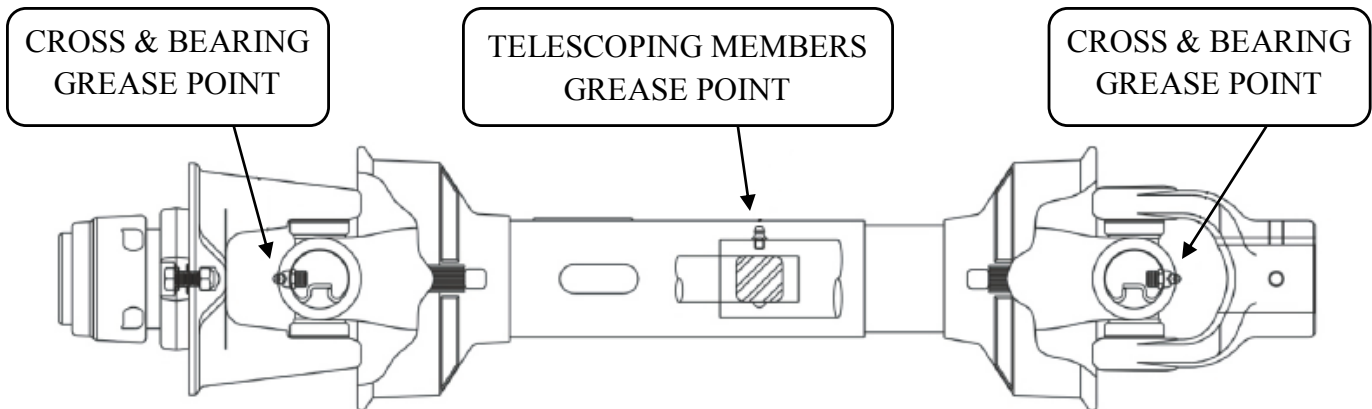

LUBRICATE ALL FITTINGS WITH A GOOD QUALITY LITHIUM SOAP BASE E.P. GREASE MEETING THE N.L.G.I. #2 SPECIFICATIONS AND CONTAINING NO MORE THAN 1% MOLYBDENUM DISULFIDE. (EX. SHELL SUPER DUTY OR EQUIVALENT)

AN E.P. GREASE MEETING THE N.L.G. I. #2 SPECIFICATIONS AND CONTAINING 3% MOLYBDENUM DISULFIDE MAY BE SUBSTITUTED IN THE TELESCOPING MEMBERS ONLY. (EX. MOBIL OIL COMPANY, "MOBILE GREASE COMPANY", SHELL OIL COMPANY, "RETINAX AM", TEXACO, "MOLYTEX EP #0 AND #2.")

GREASE RECOMMENDATIONS

INTERVAL

2 HRS.**

2 HRS.**

LOCATIONS

CROSS & BEARINGS

TELESCOPING MEMBERS

AMOUNT

1 PUMP

4-8 PUMPS

CAUTION!! REPLACEMENT PARTS ARE NOT LUBRICATED

REPLACEMENT PARTS MUST BE LUBRICATED AT TIME OF ASSEMBLY. USE AMOUNT LISTED ABOVE PER LOCATION THEN FOLLOW LUBE RECOMMENDATIONS ABOVE FOR LUBRICATING INTERVALS.

PTO Maintenance

This Manual is intended to point out some of the basic safety situations which may be encountered during the normal operation and maintenance of your machine and to suggest possible ways of dealing with these conditions. Read the manufacturer's operator manuals before operating the equipment. If there are no manuals with the machine — request them from the manufacturer. Study them before you start work.

If there is something in the manuals you don't understand, ask your supervisor or equipment dealer to explain it to you.



**This Safety Alert Symbol means
Attention! Become alert!
Your safety is involved!**

Operating the PTO

When finishing operation of PTO driven equipment, shift PTO control to neutral, shut off the engine and wait until the PTO stops before getting off the tractor.

Do not wear loose fitting clothing or long, free hanging hair when operating the power take-off, or when near rotating equipment.

When operating stationary PTO driven equipment, always apply the tractor parking brake lock and block the rear wheels front and back.

To avoid injury, do not clean, adjust, unplug or service PTO driven equipment when the tractor engine is running.

Never exceed the recommended operating speed for the particular equipment in use (see implement operator's manual).

PTO mounted drive shafts must only be used for their intended purpose

Implement input drivelines, clutches and freewheels are designed for specific machine types and power requirements. They must not be replaced by any shaft other than that recommended by the implement manufacturer. Note the tractor and implement manufacturers' Operating Instructions. Ensure that the implement input driveline is securely connected at both ends.

PTO Maintenance

A) Only use a completely guarded drive system:

PTO drive systems with complete guarding, include the tractor master shield (7), the implement input driveline guard (4 - 6) and the implement shielding (8) and must be installed at all times

If any component of the guarding system has been removed for any reason, it must be replaced or repaired prior to operation of the machine.

1. Quick-release end yoke
2. Overload and overrunning clutches
3. Inner and outer sliding profiles
4. Inner and outer guard tubes
5. Guard cone
6. 1 chain, 2 chains (depending on design)
7. Tractor master shield
8. Implement safety shield

Implement input driveline

Complete implement input driveline guard SC

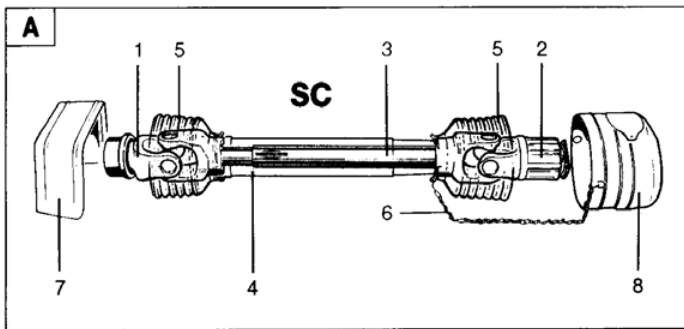

D) Lubrication (Figures D1 - D6)

→ Lubricate with quality grease before starting work and every 8 operating hours. Clean and grease the implement input driveline before each prolonged period of non-use.

Molded nipples on the guard near each guard bearing are intended as grease fittings and should be lubricated every 8 hours of operation! Telescoping members must have lubrication to operate successfully regardless whether a grease fitting is provided for that purpose! Telescoping members without fittings should be pulled apart and grease should be added manually.

* Check and grease the guard tubes in winter to prevent freezing.

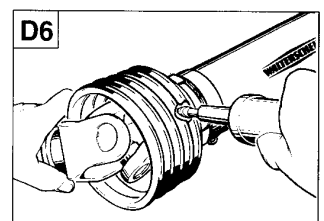
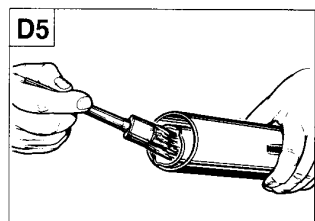
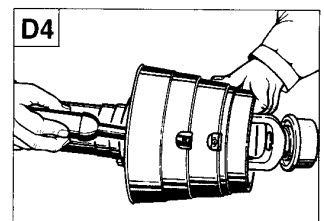
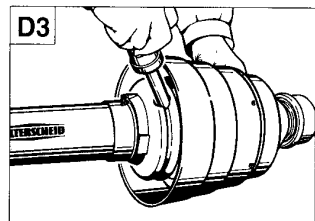
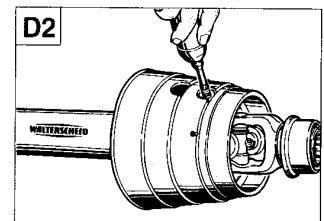
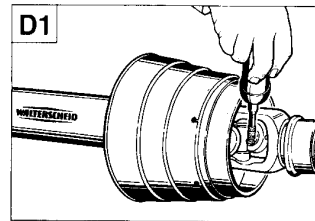
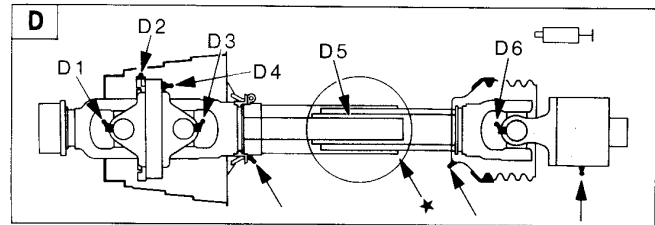

PTO Maintenance

E) Coupling the implement input driveline (Figures. E1—E3)

Clean and grease the PTO and implement input connection (II C)

AS-Lock

1. Pull locking collar and simultaneously push implement input driveline onto PTO shaft until the locking device engages.

QD Pin-Lock

2. Press QD pin and simultaneously push implement input driveline onto PTO shaft until pin engages.

Push-Pull Lock

3. Pull Locking collar and simultaneously push implement input driveline onto PTO shaft until the locking device engages



Check to insure all the locks are securely engaged before starting work with the implement input driveline.

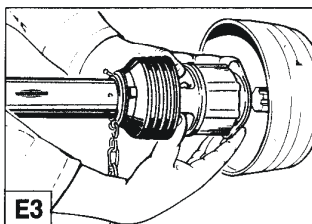
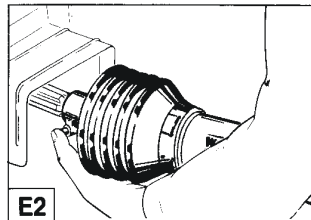
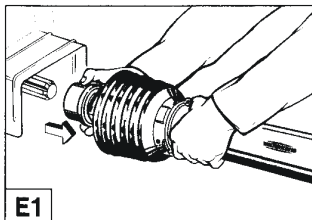

- F)  **Check the length of the telescoping members to insure the driveline will not bottom out or separate when turning and/or going over rough terrain.**

Length modification of the implement input driveline should only be done at the direction of the implement manufacturer!

G) Chains (Figure G1 - G3)

Note: The chain is intended to prevent the guard from rotating against non-moving parts and thereby reducing the likelihood of damage. A properly installed chain will increase the service life of the guard when properly maintained.

1. Chains must be attached to allow sufficient articulation of the shaft in all working positions. Care must be taken to be sure that chain does not become entangled with drawbar hitch or other restrictions during operation or transport of machine.
2. The chain is not designed to carry the weight of the implement input driveline. Damage will occur if suspended by chain.

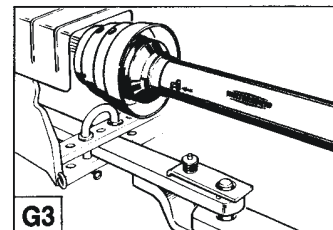
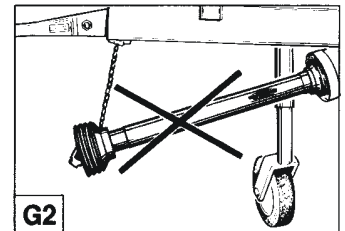
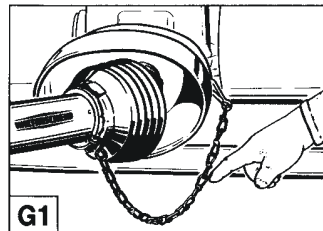

PTO Maintenance

H) Overload and overrunning clutches (Figures. H1—H8)

1. Radial pin™ clutch

When overload occurs, the torque is limited and, during the period of slipping, is transmitted in a pulsating manner. Noise acts as a warning.

2. Cut-out clutches — 3. Cam-type cut-out clutches

When the torque is exceeded, power flow is interrupted. The torque is re-established by reducing the speed of and disengaging the PTO.

4. Shear bolt clutches

When the torque is exceeded, power flow is interrupted due to the bolt shearing. The torque is re-established by replacing the broken shear bolt. Use only the bolt specified in the operator's manual for a replacement!

5. Friction clutches

When overload occurs, the torque is limited and transmitted constantly during the period of slipping. Short-duration torque peaks are limited.

! Prior to initial operation and after long periods out of use, release the pressure on the disks to insure proper function.

- Tighten nuts until friction disks are released. Rotate clutch fully.
- Turn nuts fully back. Now the clutch is ready for use.

Figure. H5 shown, also applies to other models of friction clutch (see Figure H7)

- Overrunning clutches** protect the drive against heavy rotating masses.
- Friction-type overrunning clutches** are a combination of friction clutches and overrunning clutches.
- Elastic clutches** absorb shocks and vibrations.

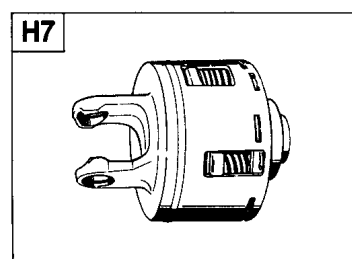
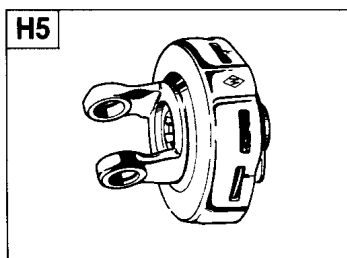
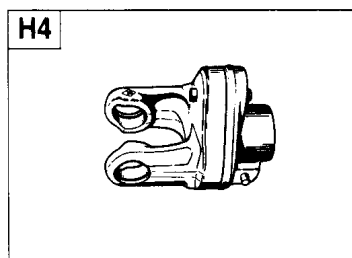

J) To disassemble guard: (Figures. J1—J4)

- Remove locking screw.
- Align bearing tabs with cone pockets.
- Remove half-guard.
- Remove bearing ring.

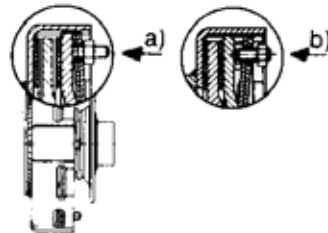
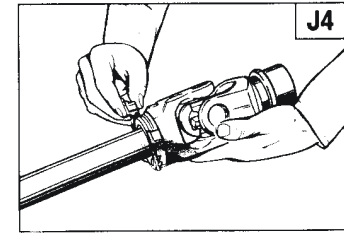
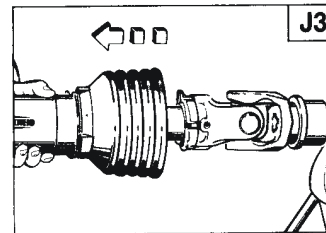
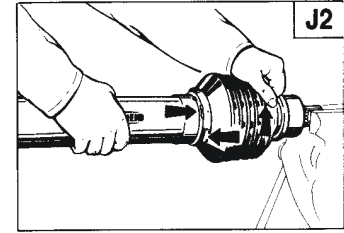
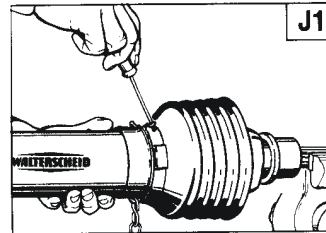

K) To assemble guard: (Figures. K1—K5)

- Grease yoke groove and inner profile tube.
- Fit bearing ring in groove with recesses facing profile tube.
- Slip on half-guard.
- Turn cone until it engages correctly.
- Install locking screw.

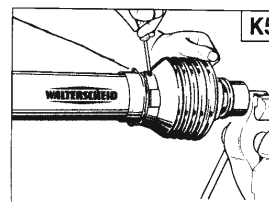
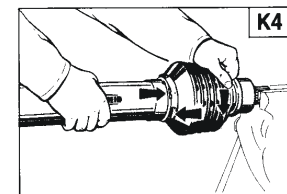
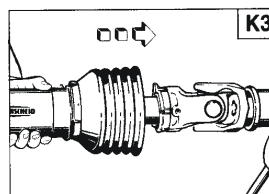
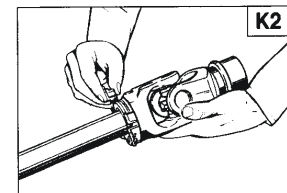
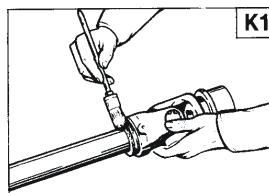

PTO Maintenance

L) To assemble cone:

1. Disassemble guard (Figures. J1 - J3). Remove old cone (e.g. cut open with knife) Take off chain. Place neck of new cone in hot water approx 80°C / 180° F and pull onto bearing housing (Figure. L1)
2. Turn guard cone into assembly position (Figure. L2). Further assembly instructions for guard (Figures. K1 - K5).
3. Reconnect chain if required (Figure. L3).

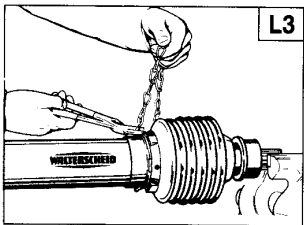
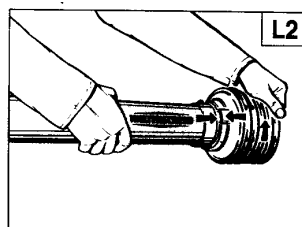
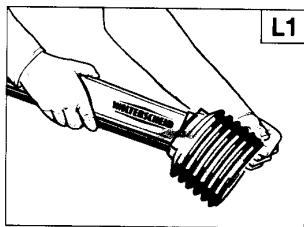

M) Disassembly: Wide-angle implement input driveline guard (Figures. M1 – M7)

1. Remove locking screws
2. Remove double yoke guard cone.
3. Remove bearing ring
4. Remove locking screw.
5. Turn cone to assembly position.
6. Remove half-guard.
7. Remove bearing ring.

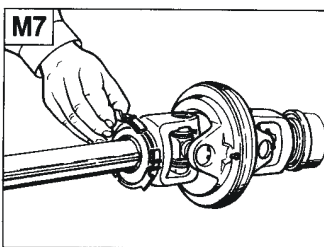
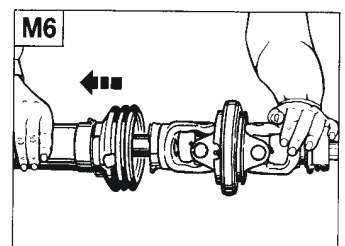
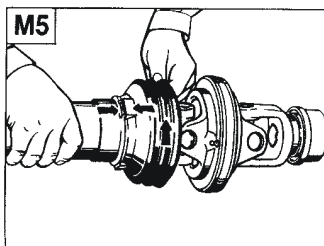
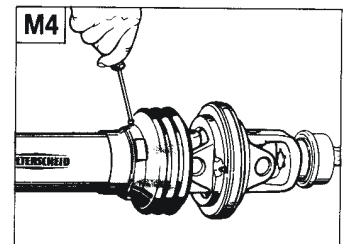
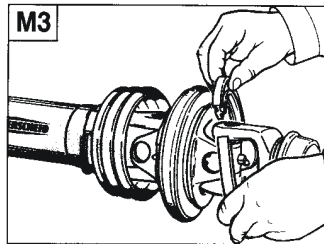
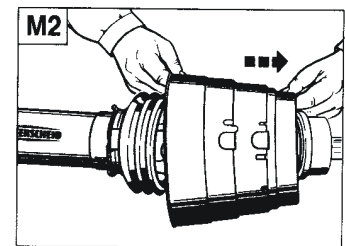
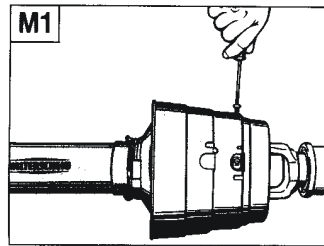

PTO Maintenance

N) Assembly: Wide-angle implement input driveline guard (Figures. N1 - N9)

1. Grease yoke groove and inner profile tube.
2. Fit bearing ring in groove with recesses facing profile tube.
3. Slip on half-guard.
4. Turn cone until it engages correctly.
5. Tighten locking screw.
6. Grease bearing groove in double yoke.
7. Insert bearing ring.
8. Slide guard cone for double yoke over cam from the connecting end. Make sure that holes for screws are visible in the recesses.
9. Tighten locking screws.

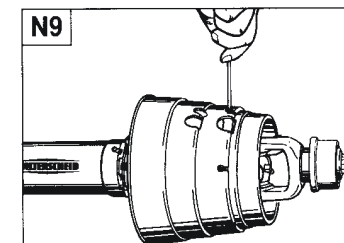
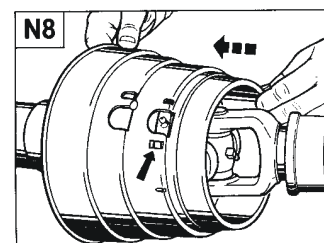
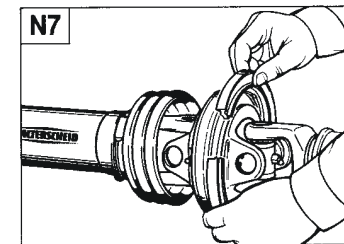
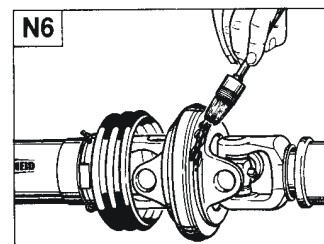
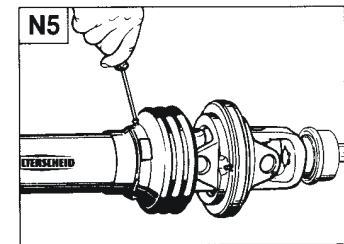
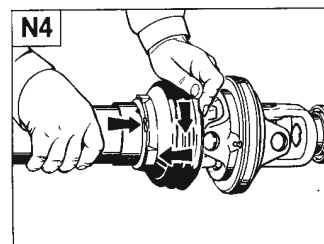
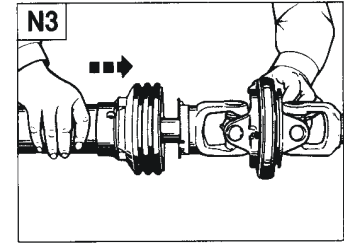
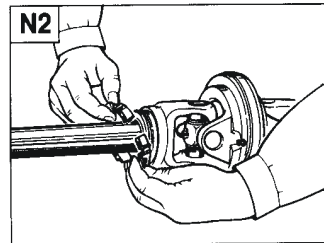
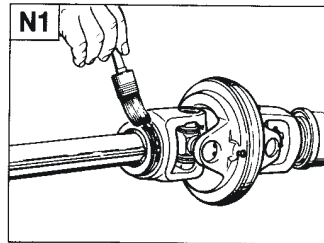

Periodic Maintenance



CAUTION

Before doing any maintenance to the hydraulic system, turn the tractor engine off and relieve all pressure from the hydraulic systems.

DAILY MAINTENANCE & INSPECTIONS BEFORE USE

1. Check air pressure in tires. **(as per recommended tire pressure)**
2. Torque wheel nuts on all tires. **(as per recommended torque specifications)**
3. Inspect all suspension parts for damage. **(repair or replace as needed)**
4. Check all oil chambers for proper oil level. **(as per recommended oil specifications)**
5. Inspect all moving components for damage. **(repair or replace as needed)**
6. Check that brakes are working correctly.
7. Check for any hydraulic oil or any oil that may be leaking out. **(repair or replace as needed)**
8. During cold weather conditions check that there is no ice build up on any moving parts. **(could prevent components from moving)**

DAILY GREASING (AS PER LUBRICATION INSTRUCTIONS)

1. PTO, joints and telescoping shafts.
2. Swivel tow bar hitch.
3. All cylinders pivot bushings.
4. All moving parts that can be greased.
5. Steering system kingpins and axle tube bushings.

EVERY 40 HOURS OF OPERATION

1. Check all oil chambers for proper oil level.
2. Torque wheel nuts on all tires. **(as per recommended torque specifications)**
3. Apply never seize to shaft on the upper vertical auger.

EVERY END OF SEASON OF OPERATION

1. Change oils in all oil chambers with recommended oil.
2. Grease steering system kingpins and axle tube bushings with extra amount of grease while turning axle in both directions in order to push out all the old grease.
3. Remove brass breather vent from bottom of steering cylinder and clean with solvent and compressed air. **DO NOT USE WIRE BRUSH, VENT WILL BE DAMAGED.**



NOTE Refer to “HYD STEERING TANDEM” in Parts Section for location.

4. **Empty unit completely.**
5. Cycle and apply never seize to shaft that goes through pillow block bearing on top of upper vertical auger.
6. Clean exterior and interior of unit thoroughly with a high pressure washer.
7. Drain unit completely. Open all drain plugs and or doors.
8. Wipe a thick coat of grease on all cylinder rods before storing unit.
9. Proceed to a complete lubrication of the unit.
10. Store inside out of the weather.
11. Check for any hydraulic oil or any oil that may be leaking out. **(Repair or replace as needed)**



WARNING

Torque lug nuts to 420 ft/lbs.
Tighten lug nuts before each day's use for the first 5 days.

Steering Lubrication Tandem Axle

There are two (2) grease fittings located on each side of the center pivot tube; one (1) on the upper inner and one (1) on the lower outer point of the round center pivot tube on each Tandem arm.

There is one (1) grease fitting located on each of the kingpins.

To grease the hinge kingpins, it is best to have the wheels steering straight one time, to the left the next time and finally to the right. This process insures that grease is getting to all areas of the kingpin.

Grease each location until new grease can be seen being pushed out.

The king pin requires grease every 4 hours the unit is in operation.

Proper steering is dependent upon adequate greasing.

When conditions are dry and dusty, the tandem arms and kingpins will require grease more often.

The tandem axle pivot tube requires grease every 8 hours the unit is in operation.

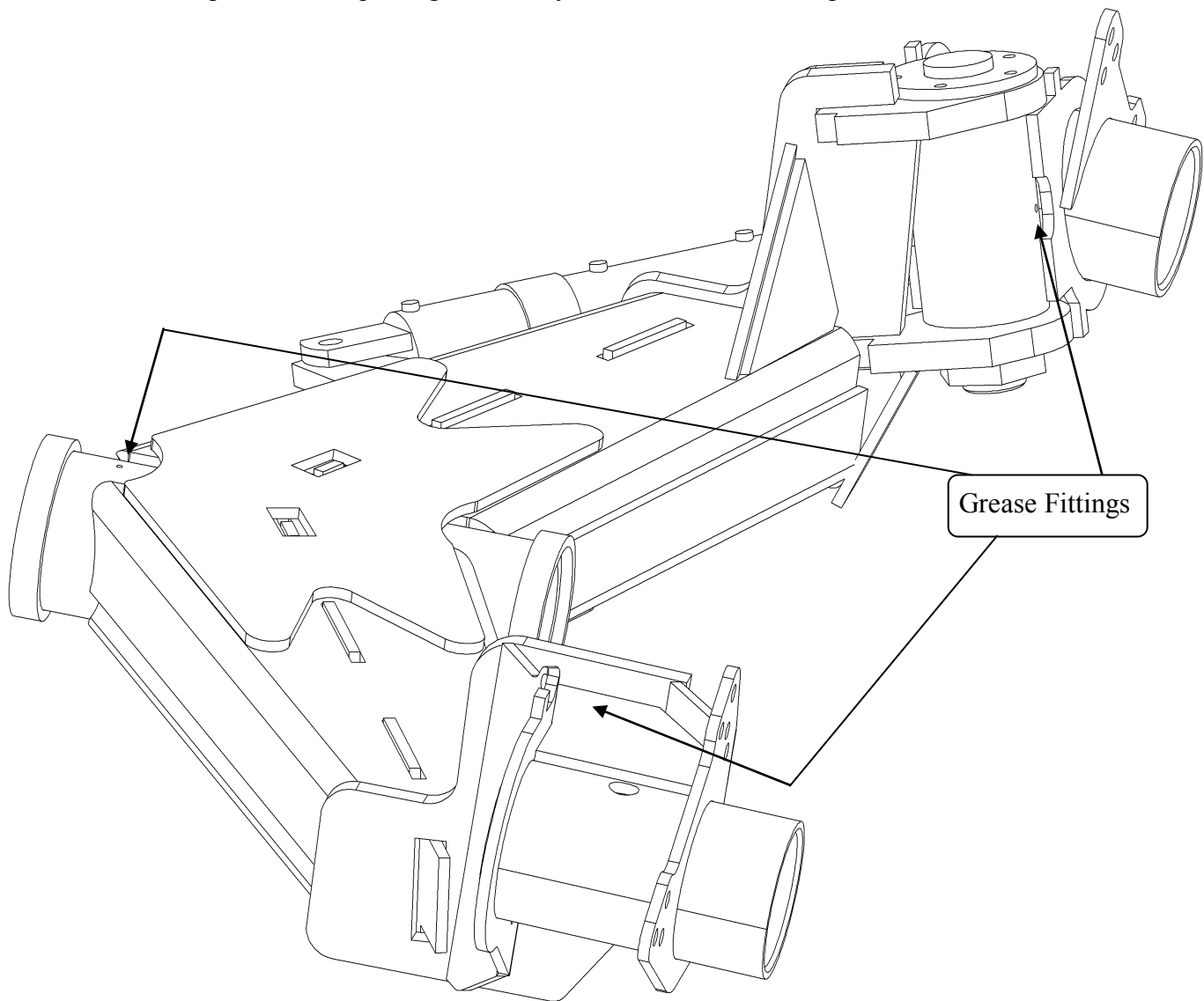

NOTE Grease thoroughly after pressure washing near kingpins.

Steering Lubrication Tridem

There is one (1) grease fitting located on each kingpin.

There is one (1) grease fitting located at each end of the tie rod.

To grease the hinge kingpins, it is best to have the wheels steering straight one time, to the left the next time and finally to the right. This process insures that grease is getting to all areas of the kingpin.

Grease each location until new grease can be seen being pushed out.

The kingpin and tie rod requires grease every 4 hours the unit is in operation.

Proper steering is dependent upon adequate greasing.

When conditions are dry and dusty, the kingpins and tie rods will require grease more often.

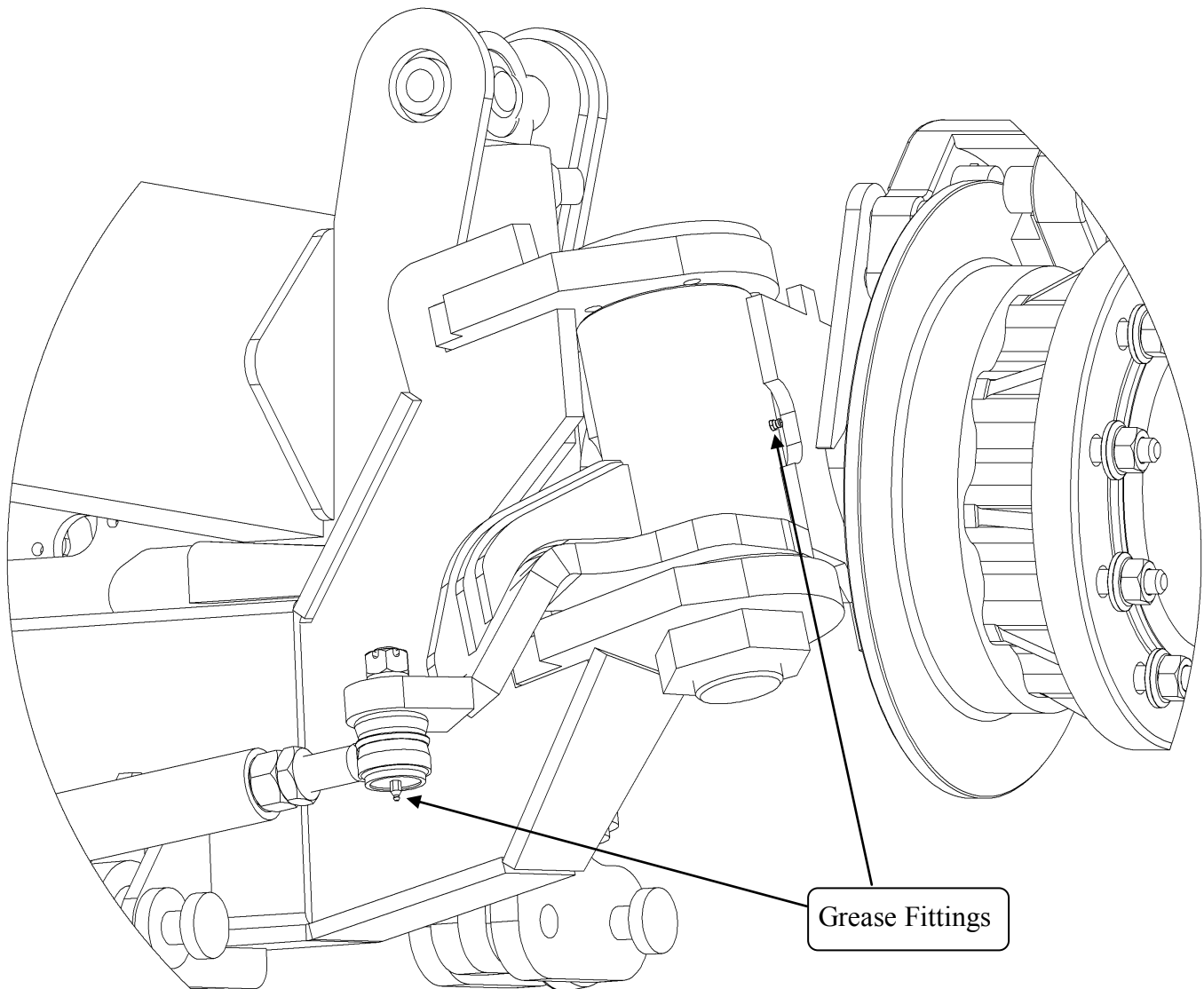

NOTE Grease thoroughly after pressure washing near kingpins.

Hub

Check and pack wheel hub bearings seasonally with an EP2 Grease.

The inside of hub is filled about 75% with grease, leaving an air space to allow for expansion from heat. On all assemblies we tighten the nut with a wrench until the hub doesn't rotate freely by one hand (while tightening turn the hub the opposite direction of the nut), back the nut off 1/2 round and retighten the nut to the next closest slot. NOTE - The washer must be lubricated prior to assembly. If the nut is loose at this next slot, remove the nut and try using another nut. The hub should rotate with one hand, the radial momentum will keep the hub rotating for a partial round (1/8-1/4 turn) after letting go with the hand depending on speed of rotation. This should give the desired preload. Ensure that the wrench does not drag against the hub while tightening.

Check preload after 5-10 hours use.

Remove and check all bearings annually (assembly and preload instructions above).

This applies to all assemblies prior to having wheels mounted on them.

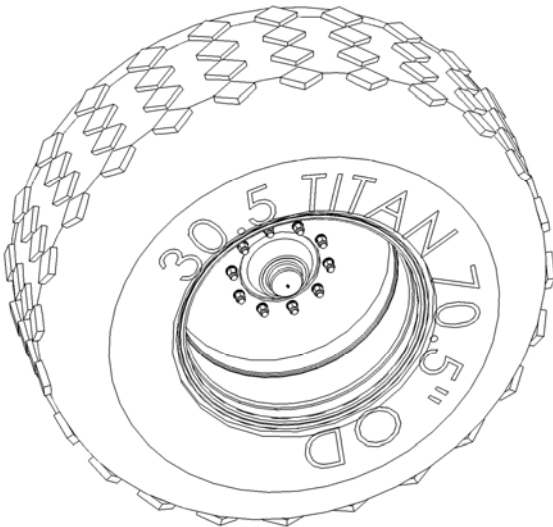

Hitch

A grease fitting is located on top of the hitch. This should be greased every day under normal conditions.

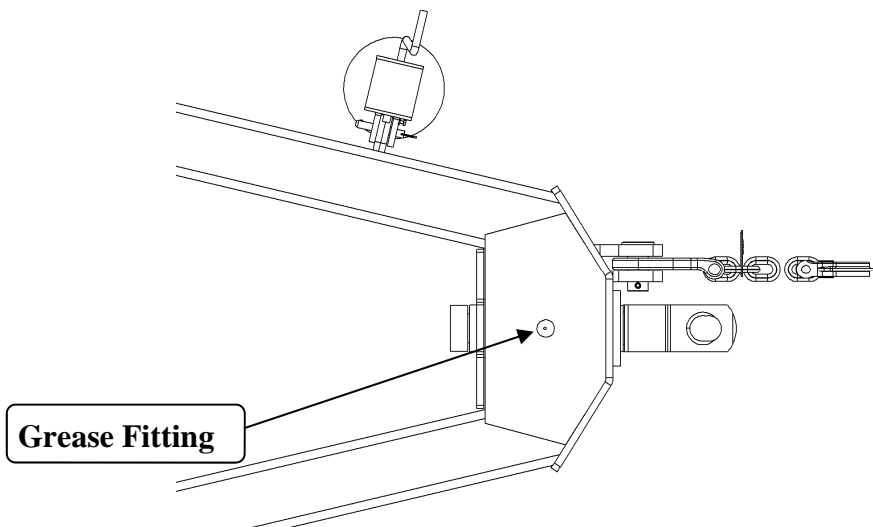

Automatic Chain Oiler

Fill oiler reservoir with chain oil. See Oiler Viscosity Chart below. Remove shields P# 91332 and P# 41704. If grain cart is equipped with the joystick controller, press trigger for auger clutch and check for oil flow at the brushes. If grain cart is not equipped with the joystick controller, engage tractor control for auger clutch and check for oil flow at the brushes. Wait two to three seconds and repeat until oil flow is present.

TO ADJUST THE LUBE MINDER PUMP FOR PROPER OIL OUTPUT

IMPORTANT - USE TWO WRENCHES

- A. One on the bottom flat part of pump
- B. The other on the brass threaded screw

1. First, loosen the jam nut on the bottom of the oiler and
2. For Less Oil – Turn Screw up
3. For More Oil – Turn Screw down

Note: Do not exceed 15 turns in any one direction!



Temperature Range	Oil Viscosity
20-40° F	SAE 20
40-100° F	SAE 30
100-120° F	SAE 40
120-140° F	SAE 50

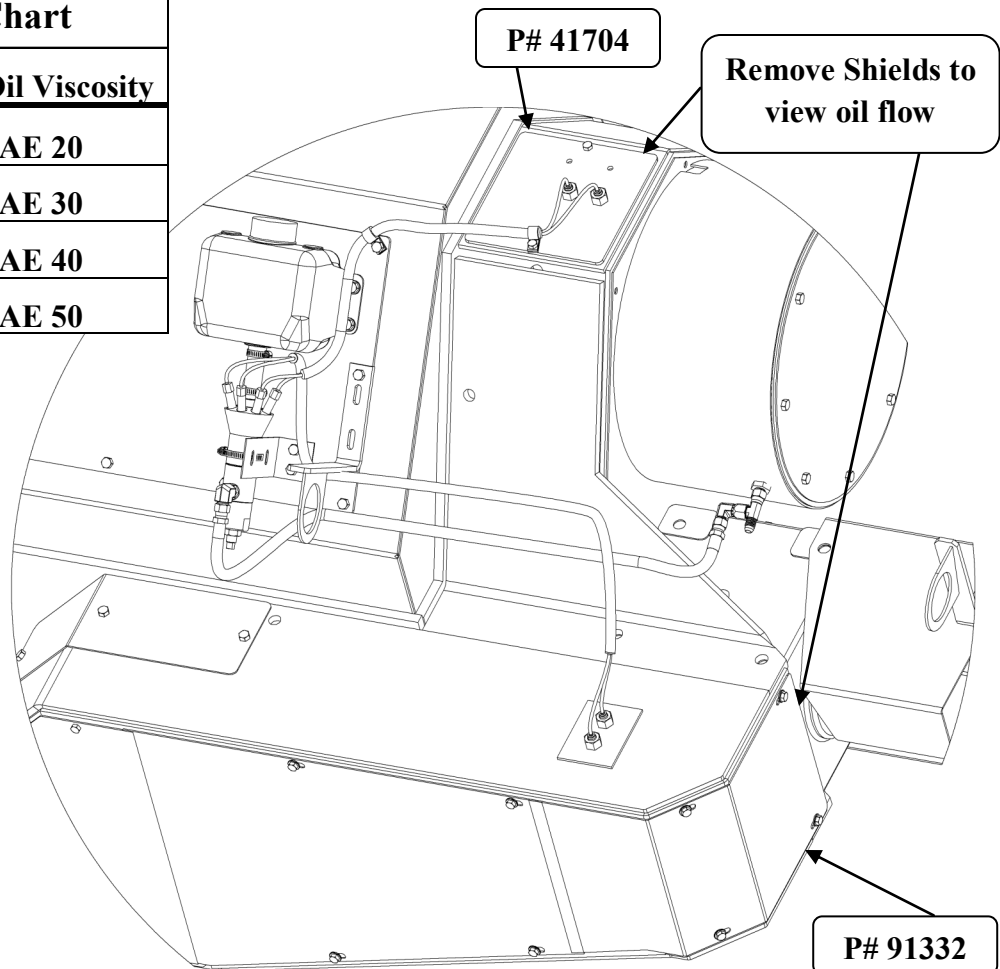

Horizontal Auger

The bearing located at the rear end of the horizontal auger should get 1 to 2 careful pumps of grease every 2 days of constant use.

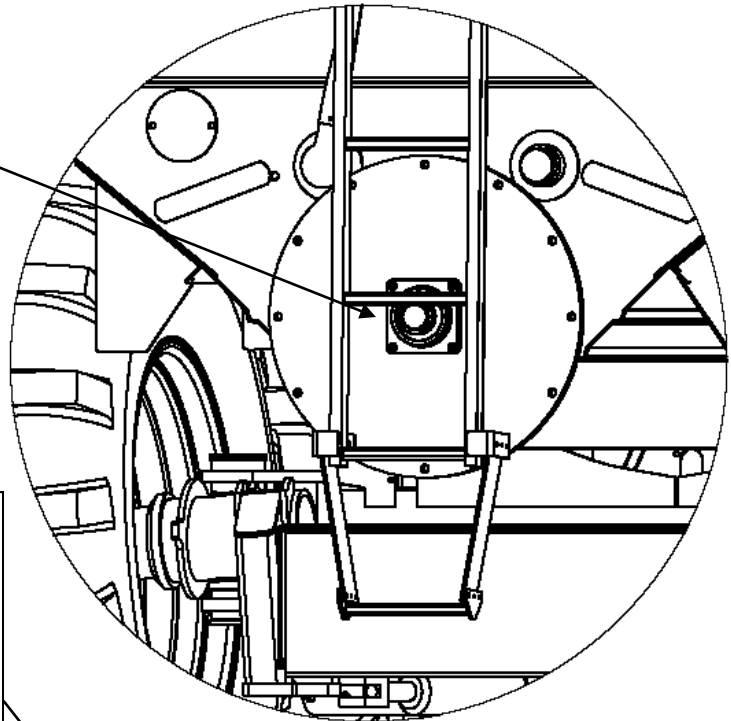

The bearing at the front end of the horizontal auger has a grease line and fitting that permits greasing externally. This location should get 1 to 2 careful pumps of grease every day of constant use.

The bearing at the bottom end of the vertical auger has a grease line and fitting that permits greasing externally. This location should get 1 to 2 careful pumps of grease every day of constant use.

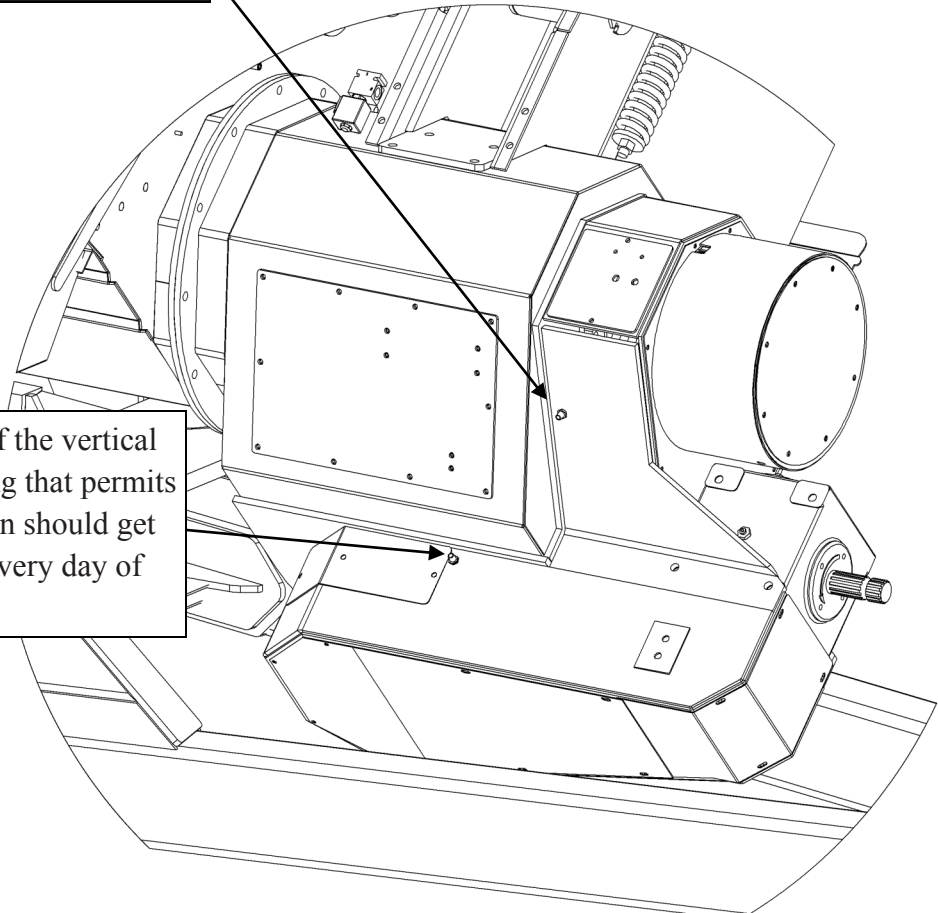

CAUTION

Excessive pressure while applying grease can be harmful to the bearing seals.

Vertical Auger

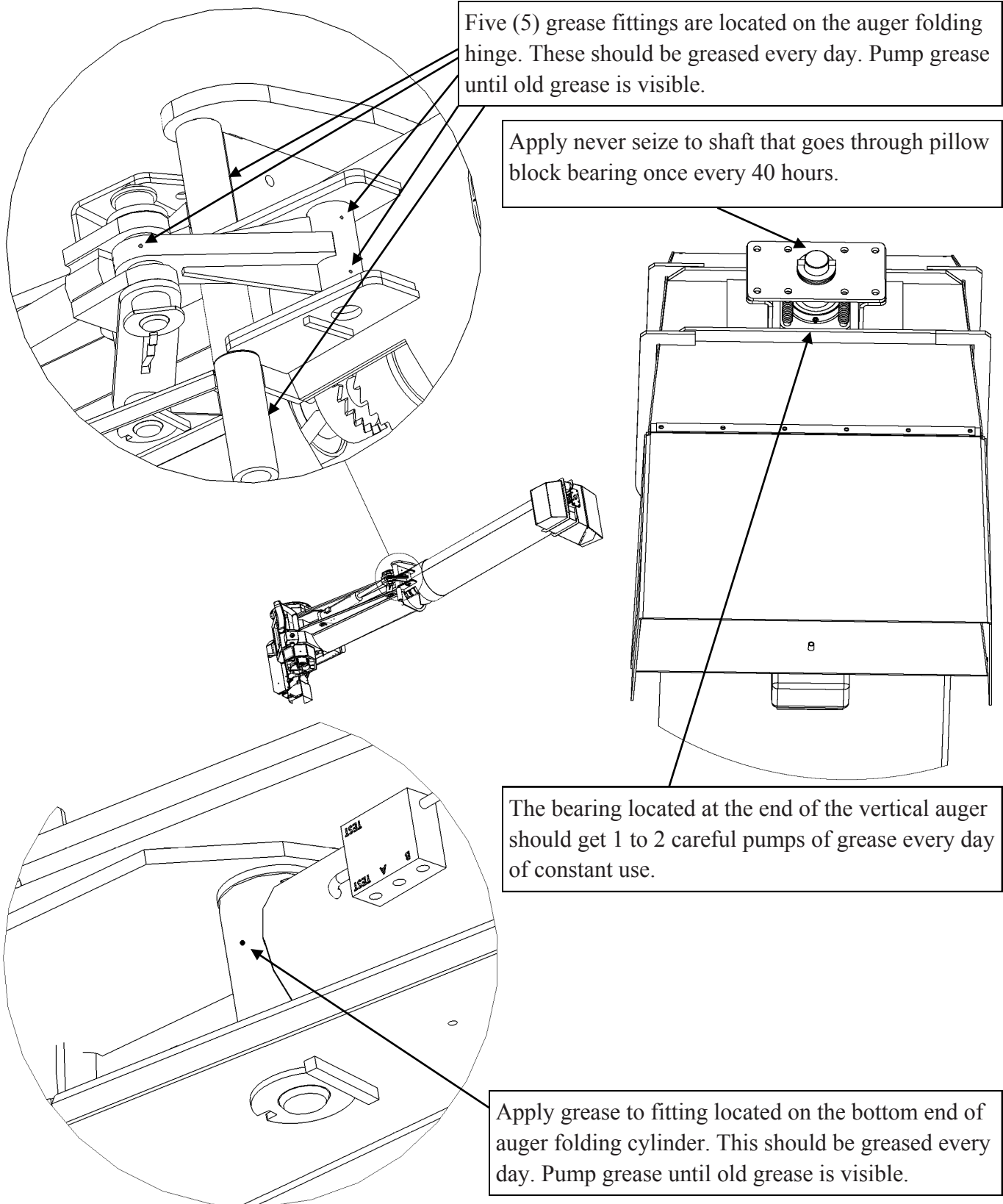

CAUTION Excessive pressure while applying grease can be harmful to the bearing seals.

Vertical Auger Continued

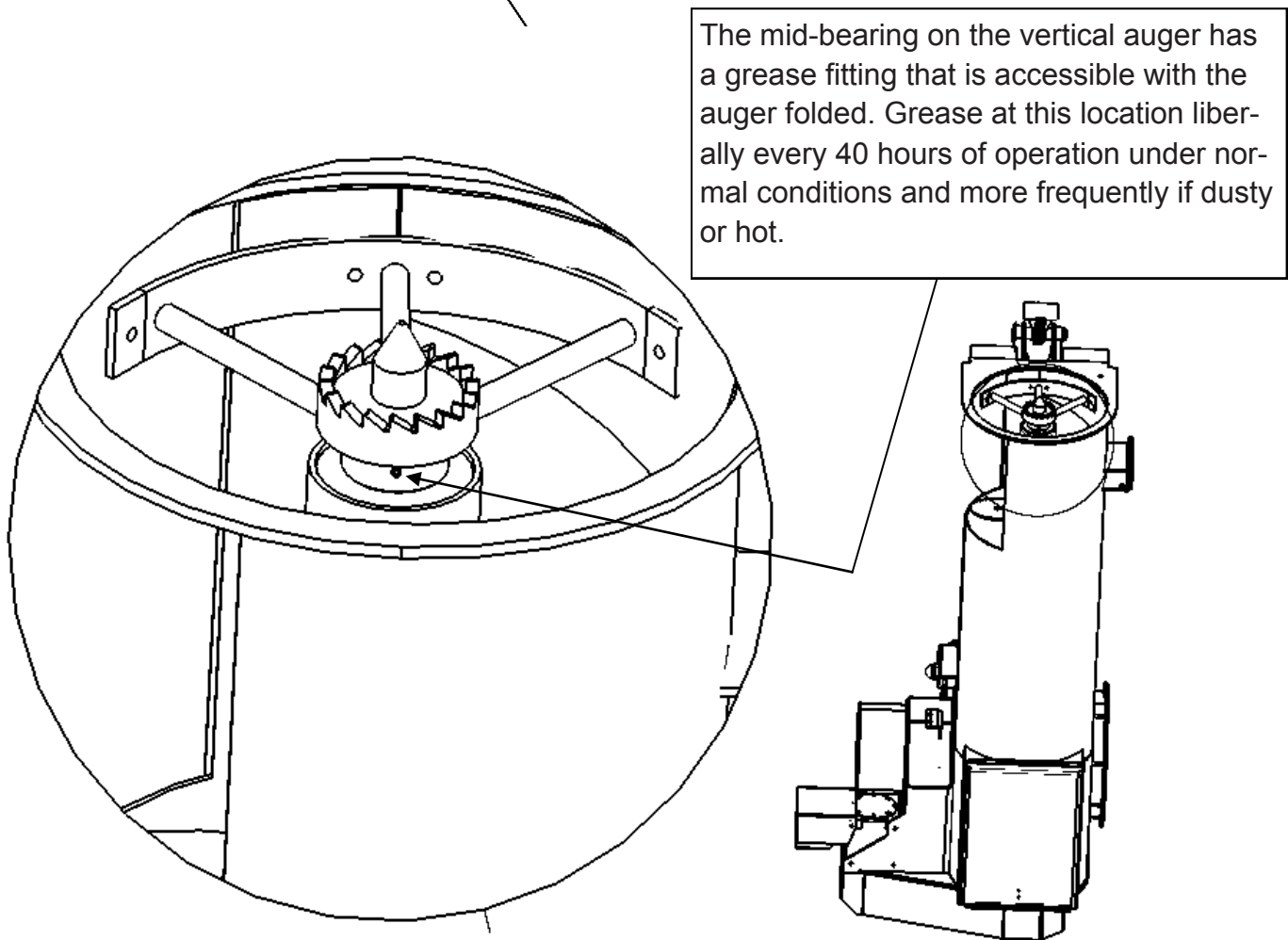
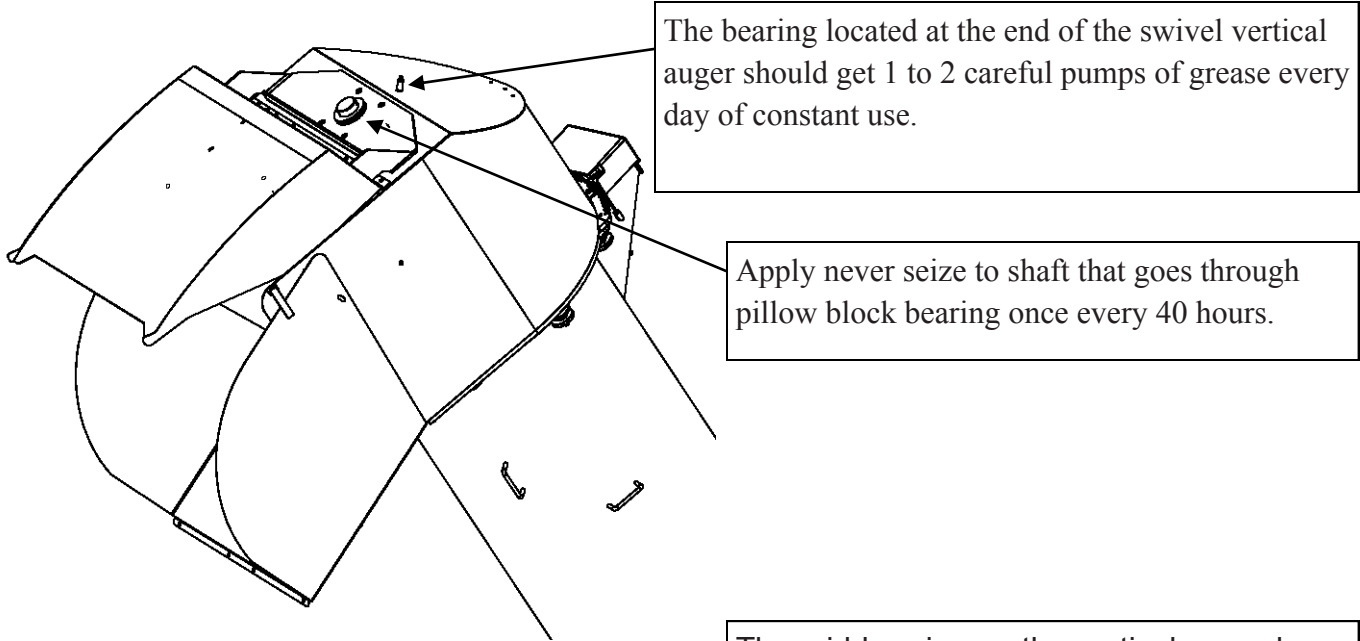

CAUTION Excessive pressure while applying grease can be harmful to the bearing seals.

Gearbox



NOTE

A small amount of moisture in the gearbox is common due to condensation when the warm gearbox is cooled. If this occurs, change the gearbox oil and continue to inspect it frequently. Regular changing of oil will minimize chance for failure and the need for repairs.



NOTE

Fill gearbox with 80W90 oil.

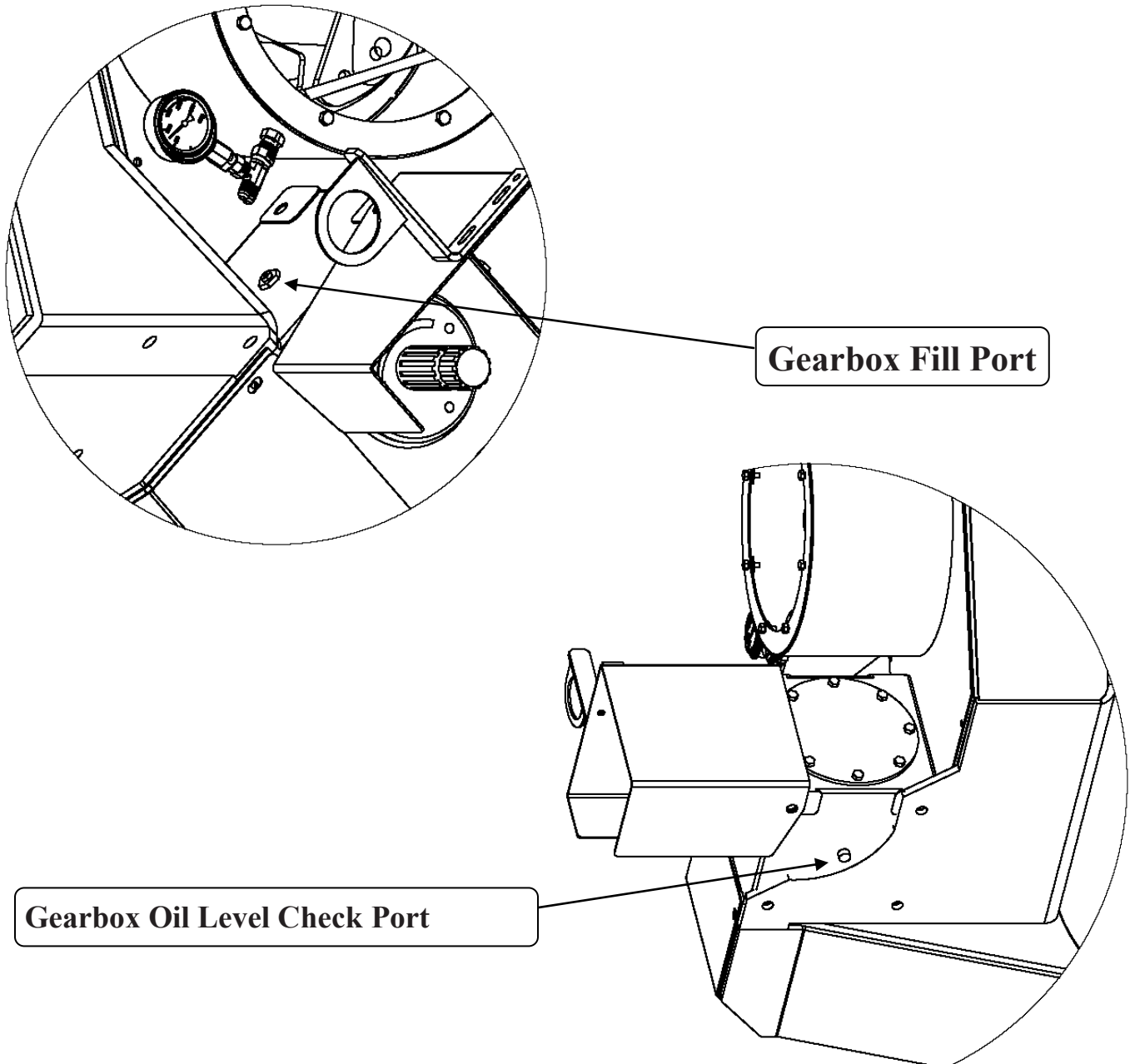



1) Trouble with steering of rear axles on Tandem or front and rear of Tridem models.

- A) Ensure the hydraulic line for the steering (**YELLOW color**) is in the float side of the tractors hydraulic bank.
- B) Grease the kingpin assemblies two (2) grease fittings on both sides in the straight position and in the turned position. This kingpin assembly must be greased daily in order for the steering system to function properly.
- C) Remove brass breather vent from bottom of steering cylinder and clean with solvent and compressed air. **DO NOT USE WIRE BRUSH, VENT WILL BE DAMAGED.**
- D) System may have air trapped inside resulting in a malfunction. This requires the hydraulic steering system to be bled. See “Bleeding Instructions for Tandem Auto Steering” or “Bleeding Instructions for Tridem Auto Steering”
- E) If the system is still not steering properly, call Balzer’s Service Department at 1-800-795-8551 Extension 134 or 0 for the operator.

2) Automatic chain oiler doesn’t appear to let oil drain.

- A) Pump may need to be primed.

TO PRIME THE LUBE MINDER PUMP AT START-UP

IMPORTANT: If oil does not cycle through pump you may have an air lock. To get rid of air lock, you need to:

- A. Remove plug
- B. Wait about 3 seconds for oil to come up to top
- C. Replace plug

Cycle Auger and verify oil is going through the lines.



- B) If this doesn’t work, call Balzer’s Service Department at 1-800-795-8551 Extension 134 or 0 for the operator.

3) Trouble figuring out which hydraulic hoses go where.

- A) RED marked hose = Brake Cylinders (Note: if option is available on your cart.)
- B) YELLOW marked hose = Steering System
- C) BLUE marked hose = Inside Grain Doors
- D) BLUE/RED = Swivel Auger Controls (Note: if option is available on your cart.)
- E) ORANGE marked hose = Unload Auger Fold
- F) NO COLOR = Clutch

4) Unload auger has abnormal vibration.

- A) Ensure the hydraulic fold cylinder is extended to the full stroke position. This is needed in order to lock the two halves together.
- B) May require the clevis on the high end of the hydraulic cylinder to be adjusted to ensure the system is being locked when the cylinder is in the full stroke position.
- C) Ensure the drive train tensioner has been properly adjusted to take the slack out of the chain.
- D) If the vibration does not stop, call Balzer's Service Department at 1-800-795-8551 Extension 134 or 0 for the operator.



NOTE

“Grain Door Timing” In most cases, each time the grain doors are closed, they will re-open evenly. If this is not occurring and is considered a problem contact Balzer for information and help solving the situation.

5) Trouble backing up with steering wheels going in the wrong direction (Note: This may occur in extreme conditions such as mud, ice and/or snow.)

- A) Take the hydraulic line out of the float position and then move the lever to pressurize the cylinders. This will straighten the tires and then lock them.
- B) System is still not steering properly, call Balzer's Service Department at 1-800-795-8551 Extension 134 or 0 for the operator.

6) Vertical upper auger will not fold down.

- A) Unplug the weather pack wire connection from valve body solenoid that controls the clutch. (Marked #3)
- B) Unplug the weather pack wire connection from the solenoid valve that controls the upper auger folding cylinder. (Marked #9)
- C) Plug the wire from the valve body solenoid that controls the clutch (Marked #3) into the wire from the solenoid valve that controls the upper auger folding cylinder. (Female Wire Marked #3)
- D) Rotate swivel auger so it is straight up and down.



WARNING

Make sure that swivel auger clears grain cart body as auger is folded down.

- E) Push and hold trigger to run clutch. This will lower vertical upper auger down to the saddle.



CAUTION

This will temporarily bypass the safety device to prevent folding swivel auger when auger is not rotated correctly.

- F) Now re-adjust magnetic limit switch till RED light on the joystick turns on.
- G) Reconnect the wires. (Wires Marked #3 and #9)
- H) If auger still will not fold up or down, call Balzer's Service Department at 1-800-795-8551 extension 134 or 0 for the operator.

7) When unfolding vertical upper auger to unload, it is slamming down hard.

- A) Unfold vertical upper auger all the way.
- B) There is a bleeder screw on the vertical upper auger on the rod end of the cylinder. Crack open the screw just a little to let the air bubbles out.
- C) Close bleed screw tightly.
- D) You might have to fold and unfold vertical upper auger a couple of times to push all the air out.
- E) If auger is still slamming down hard, call Balzer's Service Department at 1-800-795-8551 extension 134 or 0 for the operator.

8) Joystick will not work.

- A) Check and make sure that you have a minimum of 11 volts at all times.



NOTE

Some tractors with a lot of electrical devices turned on at the same time may run a little low on voltage. Try turning off un-needed devices to obtain the minimum voltage level.

- B) If joystick is still not working, call Balzer's Service Department at 1-800-795-8551 extension 134 or 0 for the operator.
- 9) Auger will not disengage after it is shut off.

NON SWIVEL AUGER

- A) Take the line from the relief block and hook it up to a zero pressure return line on the tractor.

SWIVEL AUGER

- A) Take the return line from the valve body and hook it up to a zero pressure return line from the tractor.



NOTE

May need to have a zero pressure return port installed on the tractor. Not all tractors are equipped with this port. (Contact your tractor dealer to have this installed.)

Horizontal Drive Service Information

For horizontal auger, adjust chain tensioner so that in tightest position there is a 1/2" - 13 mm deflection on the tight side of chain. Ensure all three sprockets are aligned to avoid premature wearing of the chain.

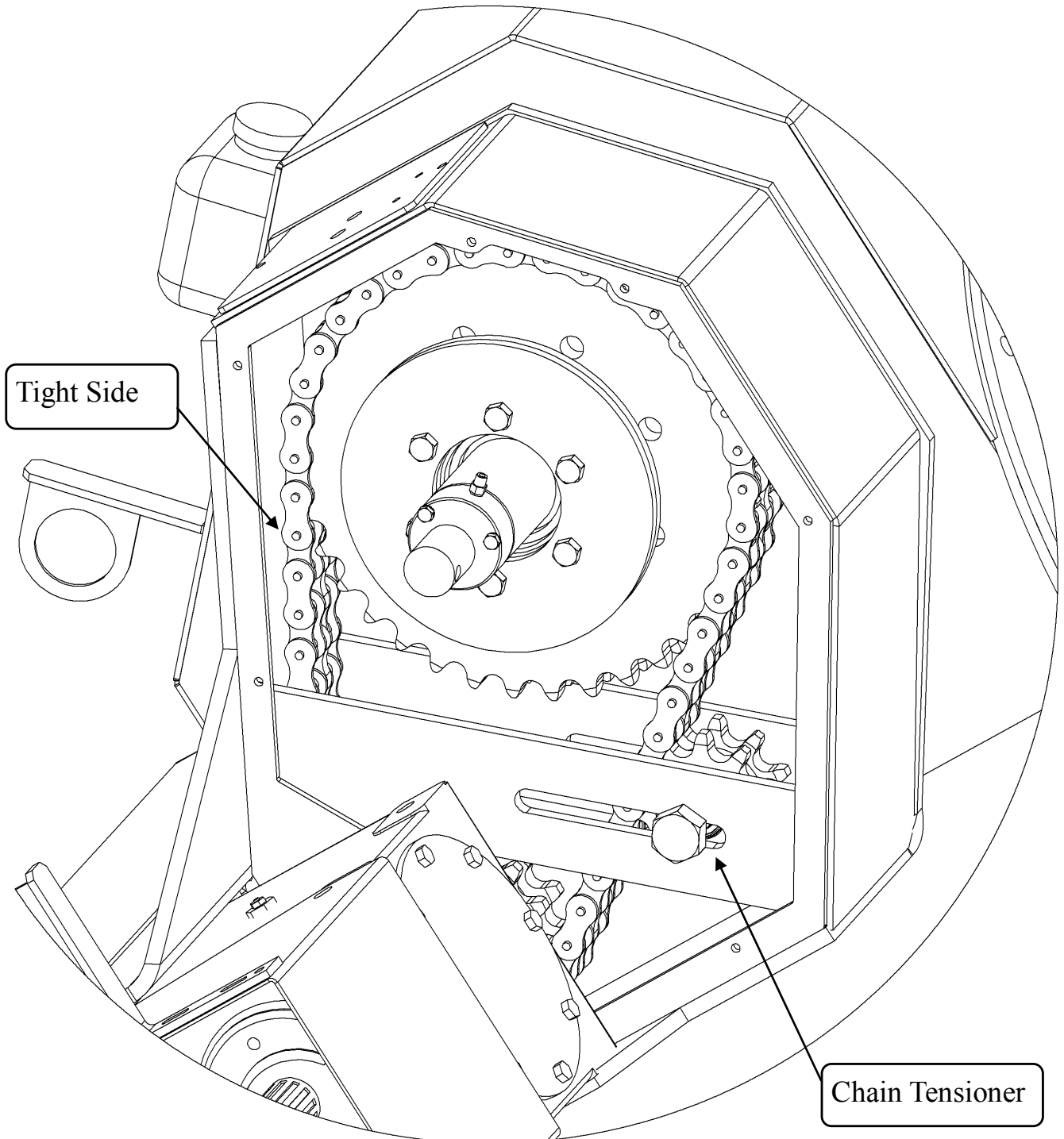

Vertical Drive Service Information

For vertical auger, adjust chain tensioner so that in tightest position there is a 1/2" - 13 mm deflection on the tight side of chain. Ensure all three sprockets are aligned to avoid premature wearing of the chain.

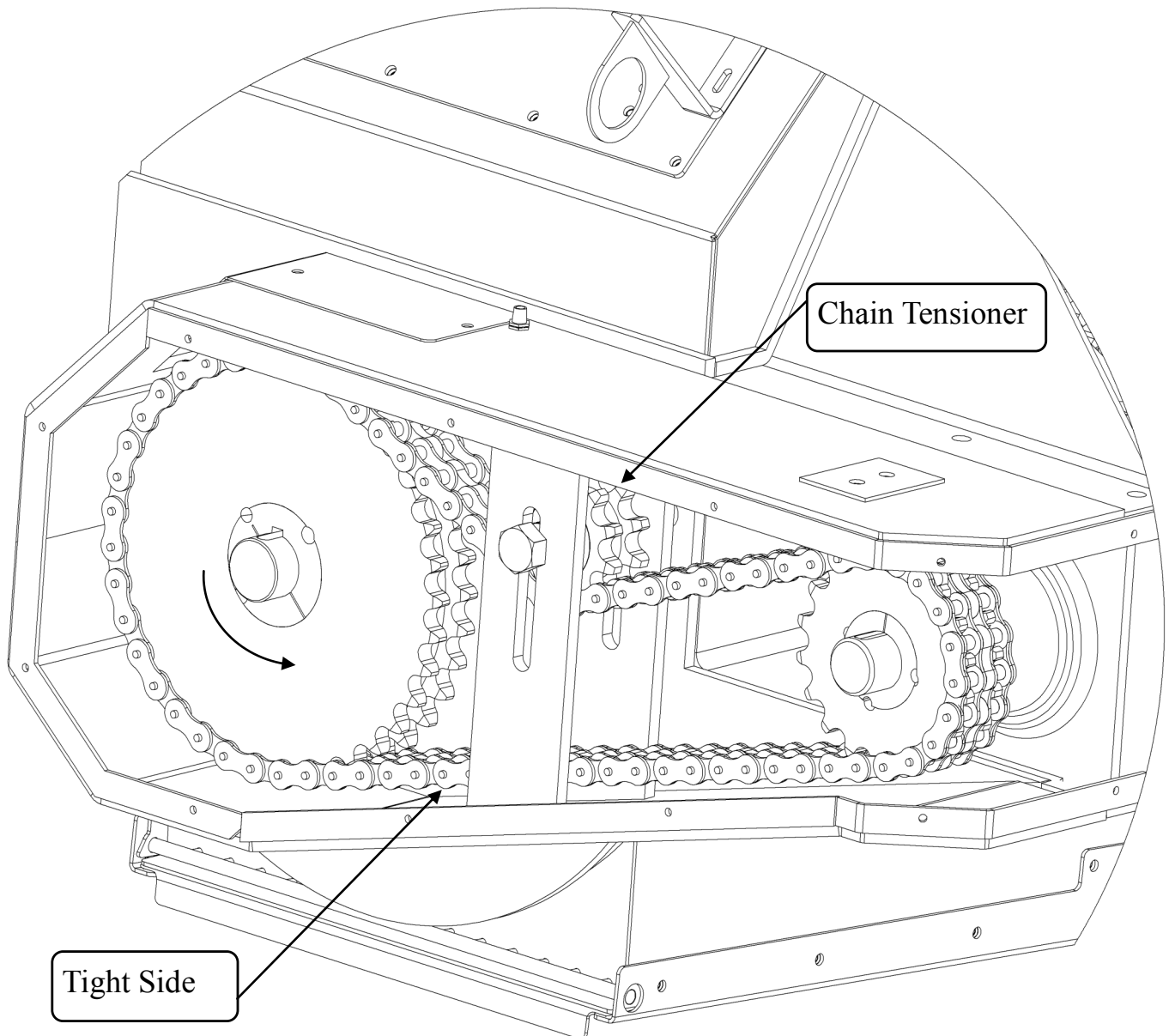

Vertical Auger Engagement Information



WARNING

Auger should be blocked between upper and lower vertical auger sections to prevent potential pinch hazard.

INSTALLATION INSTRUCTIONS

UPPER PORTION

Raise upper vertical auger housing as shown in picture. Measure distance from tooth tip to vertical auger housing flange, the measurement should be 2 1/8" - 2 3/8" or (54-60mm). If dimension is off, lower upper vertical auger housing back down to saddle and add or remove shims to adjust the offset.

LOWER PORTION

Measure distance from tooth tip to lower vertical housing flange, the measurement should be 1 3/8" - 1 1/2" (35-38mm).

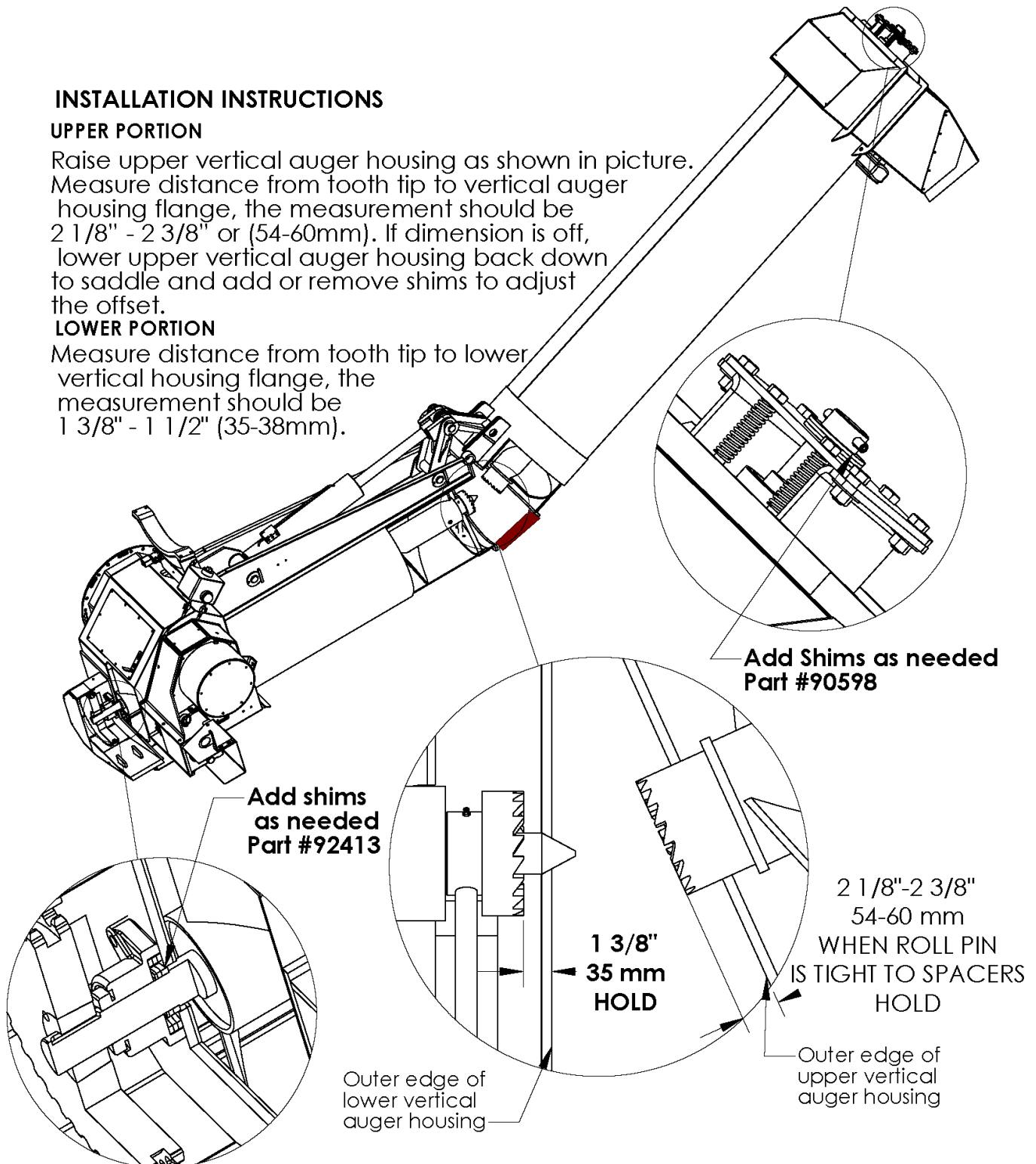

Notes



A series of horizontal black lines for writing notes.



County Road 27 East, PO Box 458, Mountain Lake, MN 56159

Phone Number:

(800) 795-8551

(800) 727-3133

Main:

(507) 427-3133

Fax Number:

(507) 427-3640

Website:

<http://www.balzerinc.com>

