

balzer mfg
corp

highway 60 east
mountain lake, mn. 56159
phone (507) 427-3133

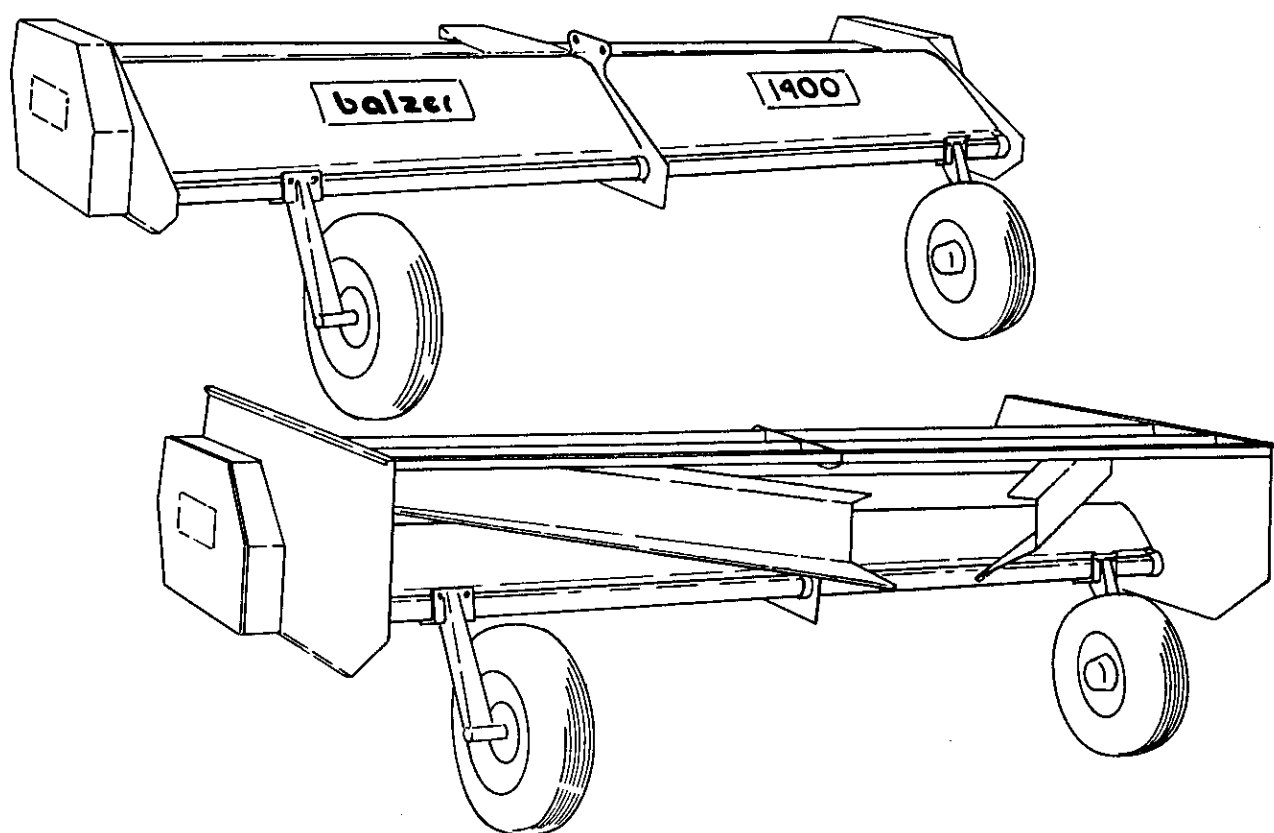

**FLAIL SHREDDERS
OPERATORS & SERVICE MANUAL
for Conventional & Windrow Models
1200, 1400 & 1500**

PN 13024

Table of Contents

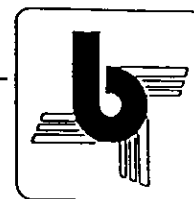

SAFETY	1
TO THE PURCHASER	4
SET-UP & ASSEMBLY	5
OPERATION	7
SERVICE & LUBRICATION	8
INSTRUCTIONS FOR ORDER PARTS	10
CYLINDER ASSEMBLY	11
MAIN ASSEMBLY	12
GEAR BOX ASSEMBLY	14
PTO ASSEMBLIES	16
DRIVE LINES	24
JACK ASSEMBLY	26
TONGUE & FULL MOUNT PARTS	27
WHEEL ASSEMBLY	28
CENTER DIVIDER, DISC HITCH & RATCHET JACK	29

Safety

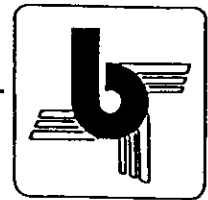

Safety Signs

WHY safety signs are important.

Safety signs or decals provide very important information and instructions designed to promote personal safety. They are designed to alert you to dangers and hazards that can be present during operation of this equipment. However, safety sign instruction does no good if it is not read, understood and followed.

WHEN safety signs must be replaced.

Safety signs or decals must be kept clean and readable. If they become unreadable for any reason they must be replaced with an identical replacement decal. Safety decals must also be replaced if parts are repaired or replaced with new parts that do not already include the necessary safety decals.

HOW to apply safety sign decals.

Surface preparation is very important for safety decals to properly adhere. Grease, oil and dirt must be removed and the surface must be smooth and dry.

Most decals have a split backing which is meant to be removed from the split outward.

1. Position the decal in the proper location and hold firmly over the largest portion of backing.
2. With one hand holding decal in position, the free hand can carefully roll the loose end over and peel backing outward. When the backing is removed as described and shown in Fig. (1), with even and gradual pull, the decal will roll onto the surface smooth and wrinkle free.
3. With the smallest portion of decal attached, the same procedure can be applied to the other half.
4. After the decal is attached in place, use a cloth or soft paper towel to burnish decal onto surface. Work gently from the middle outwards to avoid creating any wrinkles.

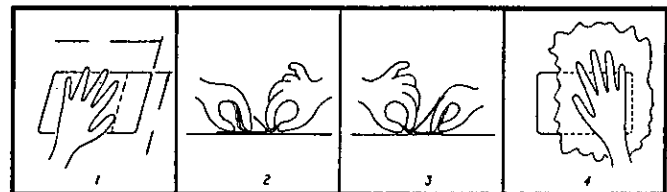
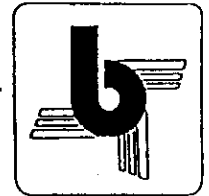

Fig. (1)

WHERE to obtain replacements.

Order replacement decals by part number through your nearest dealer. Part numbers are printed on most decals, later in this section and in the parts' section of this manual.

Safety



BE CAREFUL

1. KEEP ALL SHIELDS IN PLACE.
2. STOP ENGINE BEFORE LEAVING OPERATOR'S POSITION TO ADJUST, OIL, CLEAN OR UNCLOG MACHINES, UNLESS OTHERWISE SPECIFICALLY RECOMMENDED IN THE "OPERATORS MANUAL".
3. WAIT FOR ALL MOVEMENT TO STOP BEFORE SERVICING THE MACHINE.
4. KEEP HANDS, FEET, AND CLOTHING AWAY FROM POWER DRIVEN PARTS.
5. KEEP OFF EQUIPMENT UNLESS SEAT OR PLATFORM FOR OPERATIONS AND OBSERVATION IS PROVIDED.
6. KEEP ALL OTHERS OFF.
7. USE FLASHING WARNING LIGHTS WHEN OPERATING ON HIGHWAYS EXCEPT WHEN PROHIBITED BY LAW.
8. MAKE CERTAIN EVERYONE IS CLEAR OF MACHINE BEFORE STARTING ENGINE OR OPERATION.

10744

PIN 10744 "BE CAREFUL" DECAL

DECALS ARE LOCATED IDENTICALLY AT BOTH ENDS OF SHREDDER



P/N 15295 "DANGER"

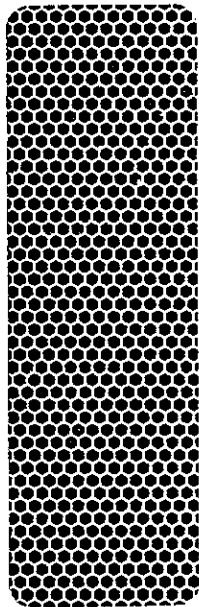

P/N 12795
AMBER REFLECTION

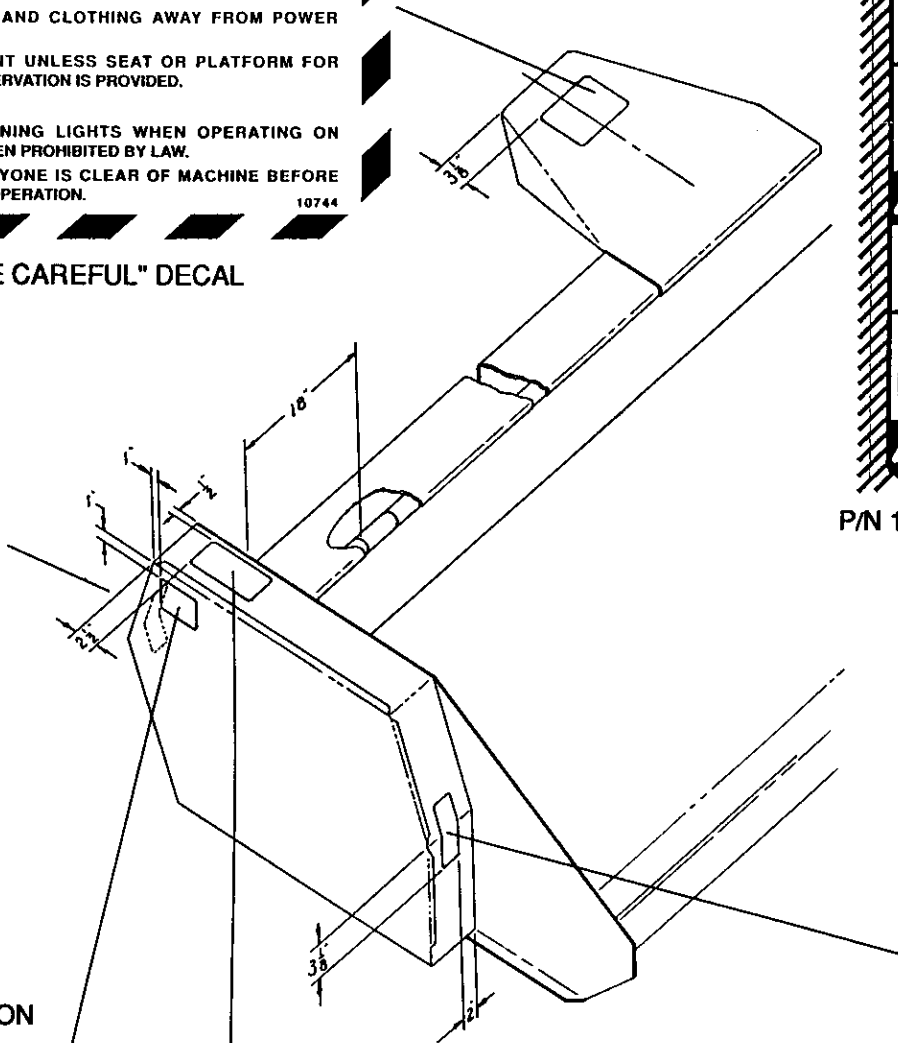

P/N 8154 "CAUTION" DECAL

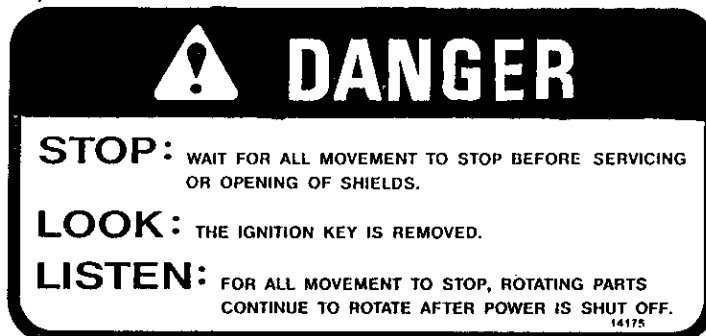

P/N 14175 "DANGER" DECAL



P/N 12794
RED REFLECTION

Shredder Safety

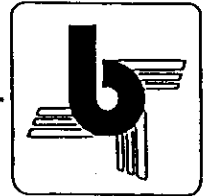

1. This machine must be operated and serviced by qualified persons who have thoroughly read and understand this operator's manual and the safety signs on the machine.

2. Read and follow the instructions on all decals.

3. Never operate shredder with any guards or shields not in place. Replace any missing or damaged shields.

4. Be sure the front flipper shields are in place and swing freely prior to operation.

5. Keep hands and feet away from all moving parts.

6. Never wear any loose clothing when working around moving parts.

7. Keep children away from machinery.

8. Never leave shredder operating unattended.

9. Never allow anyone to ride any place other than tractor's seat.

10. Do not stand in front, behind, or along side of machine when the cylinders are turning.

11. Wait for all movement of cylinders to stop before servicing or opening of the shields on the shredder.

12. Block wheels securely when machine is parked on an incline.

13. Periodically check for loose or missing hardware and tighten or replace as needed.

14. Do not work under the shredder for servicing of cutting knives or other reasons unless the machine has been safely blocked up, and the P.T.O. disconnected.

15. Replace any parts which show signs of excess wear, cracking or likely failure with original equipment service parts.

16. Make certain that everyone and everything is cleared before starting the engine or operation of the shredder.

17. Always start up unit slowly and gradually bring up to speed in order to check for abnormal operation.

18. If your shredder develops abnormal noises or excessive vibration, stop the unit at once and safely determine and correct the cause.

19. When parking always lower the shredder and block wheels.

20. Insure tire pressure is 20 p.s.i. maximum.

21. Hydraulic fluid pressure can be very dangerous and can cause serious personal injury. Be sure to relieve all pressure before disconnecting hydraulic lines.

22. Fluid escaping from a very small hole can be almost invisible. Use a piece of cardboard or wood, not your hand to search for leaks.

23. If injured by escaping hydraulic fluid seek prompt medical attention, serious infection or reaction may develop.

24. Always use a safety chain between towing vehicle and shredder when transporting.

25. Never assume that everyone is as safety conscious as you are.



DANGER

STOP: WAIT FOR ALL MOVEMENT TO STOP BEFORE SERVICING OR OPENING OF SHIELDS.

LOOK: THE IGNITION KEY IS REMOVED.

LISTEN: FOR ALL MOVEMENT TO STOP, ROTATING PARTS CONTINUE TO ROTATE AFTER POWER IS SHUT OFF.

14175

To The Purchaser

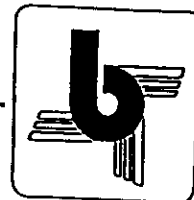

This new Balzer product is designed and manufactured to give years of dependable service when used for the purpose for which it was intended and when properly maintained. NEVER OPERATE THIS EQUIPMENT UNTIL USER FULLY UNDERSTANDS THE COMPLETE CONTENTS OF THIS MANUAL FOR OWNERS WHO DO NOT OPERATE THIS EQUIPMENT, IT IS THEIR RESPONSIBILITY THAT THE USER HAS BEEN PROPERLY INSTRUCTED AND IS FULLY AWARE OF THIS MANUAL'S CONTENTS. This is important in the safe handling of their equipment and also achieving an efficient operation. If there are questions about areas in this manual, it is important to contact your dealer for clarification.

 THIS IS THE SAFETY ALERT SYMBOL. IT IS USED TO ALERT THE OPERATOR TO AN INSTRUCTION CONCERNING THE PERSONAL SAFETY AND RISK FACTOR OF THIS EQUIPMENT. ALWAYS OBSERVE AND HEED THESE VERY IMPORTANT INSTRUCTIONS TO PROMOTE A SAFE OPERATION WITH GOOD PREVENTIVE MAINTENANCE HABITS.

All reference to "LEFT" or "RIGHT" sides is viewing equipment from rear and facing in direction it normally travels when operating.

If any part of this manual is damaged or missing, please contact your dealer to complete your manual.

ALWAYS OBTAIN ORIGINAL EQUIPMENT SERVICE PARTS FROM YOUR DEALER. NEVER ACCEPT ANY TYPE OF SUBSTITUTE ITEMS, AS THIS COULD AFFECT THE EQUIPMENT PERFORMANCE.

THIS MACHINE IS WARRANTED AS STATED ON REAR OUTSIDE COVER. HOWEVER, A REGISTRATION CARD IS TO BE FILLED IN BY YOUR DEALER WITH YOUR NAME AND ADDRESS, AND PROMPTLY RETURNED TO THE FACTORY. THE CARD PROVIDES A READY REFERENCE TO HELP YOU IN SECURING WARRANTY AND IN ANSWERING QUESTIONS THAT YOU MAY HAVE AT A LATER DATE. FURNISH THE SAME INFORMATION TO DEALER WHEN YOU ARE OBTAINING SERVICE PARTS.

We urge the return of this card so that you will receive maximum service benefits. This card does not put you on a mailing list nor is the information on the card available to anyone else.

IDENTIFICATION NO.

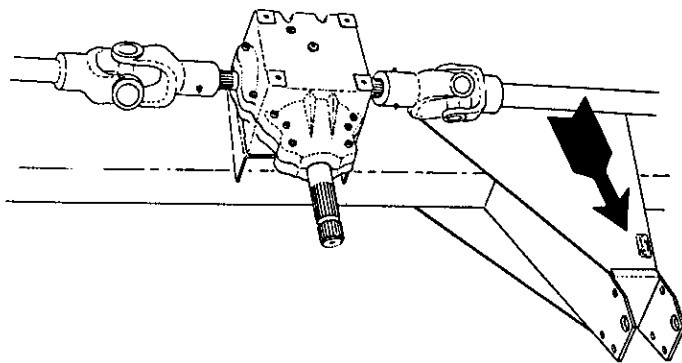

The location of either the serial number or identification number on this equipment is as shown above.

PLEASE FILL IN THE FOLLOWING INFORMATION FOR YOUR RECORDS

DATE OF PURCHASE _____

OWNER'S NAME _____

DEALER'S NAME _____

SERIAL NO. or IDENTIFICATION NO. _____

Set-Up & Assembly

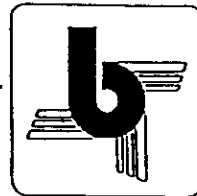

IMPORTANT INFORMATION

! If shredder must be raised off the ground to install any equipment, be sure to safely block it up. Be certain that the entire area is safe before doing anything.

WHEEL ARM ASSEMBLY

Remove hardware bag from box of parts. It contains hardware for 2 arms. If additional arms have been ordered, there will be an additional hardware bag with them.

Position the wheel arms on rock-shaft as shown for the desired row spacing. Be sure to position the wheel arms so that the tire will be in the center of the rows for best operation. The customer supplied tires should be inflated to 15-20 p.s.i.

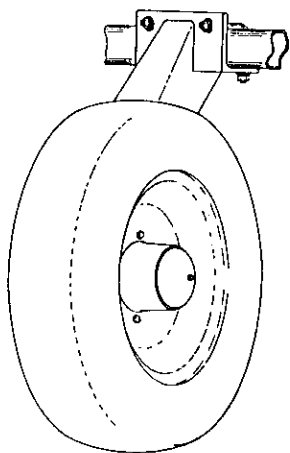

HYDRAULIC CYLINDER OR RATCHET JACK

Install a standard agricultural 3x8 hydraulic cylinder or compatible ratchet jack between the cylinder arm on the rockshaft and the mounting bracket on top of the main housing.

HOSE STAND

Remove the right front bolt on the top of the gear box shiel and stall the hose stand. Run hydraulic hoses from hydraulic cylinder through stand to the tractor. The stand is in the box of parts.

IMPLEMENT JACK

Remove jack from the box of parts. Install it onto mount that is located on the outside of the left hitch arm at the front of the shredder.

HINGING GUARDS

Remove hinging guards and 2 roll pins from box of parts, and locate the 2 hinge rods. Each are either 6 or 7 foot long, depending on model. Slide one hinge rod halfway through the center hinge tab while positioning hinging guard between center hinge tab and the next one. Slide the hinge rod through the hinge pipe, repeat until are in place on one side. Insert roll pin in rod hole that appears between the outside hinge tab and the end panel. Refer to illustrations below. Hinging guard installation.

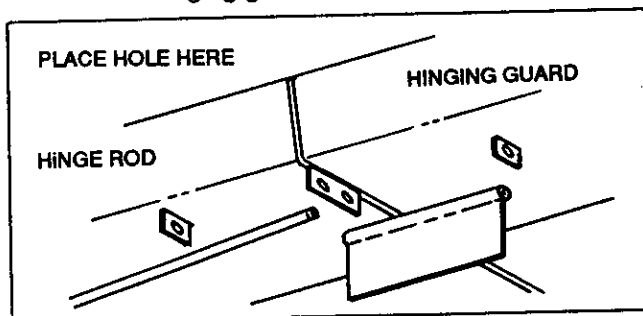

ROLL PIN PLACEMENT

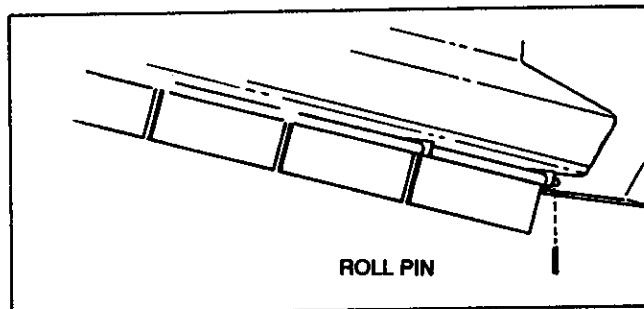

TORQUE CHART

RECOMMENDED TORQUE IN FOOT-POUNDS COARSE AND FINE THREAD	
BOLT MARKING	GRADE 5
BOLT DIA.	TORQUE
1.4	10
5/16	18
3/8	39
7/16	58
1/2	87
9/16	111
5/8	173
3/4	290
7/8	500
1	620

Set-Up & Assembly

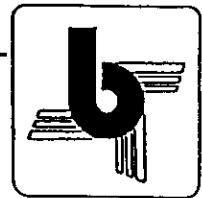

SUGGESTED MOUNTING ADJUSTMENT FOR FULL MOUNT & PULL TYPE

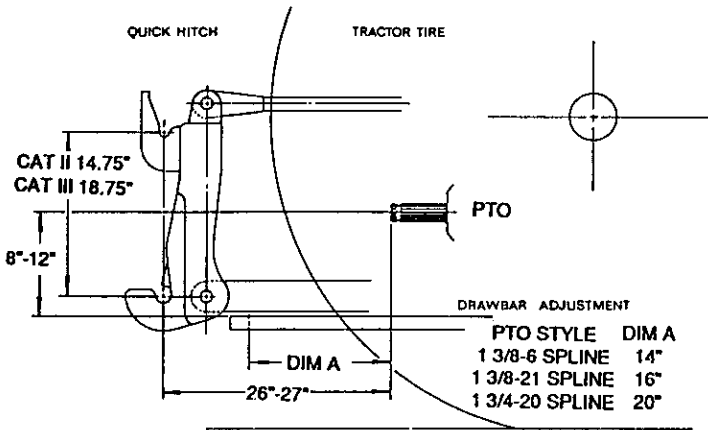

PULL TYPE

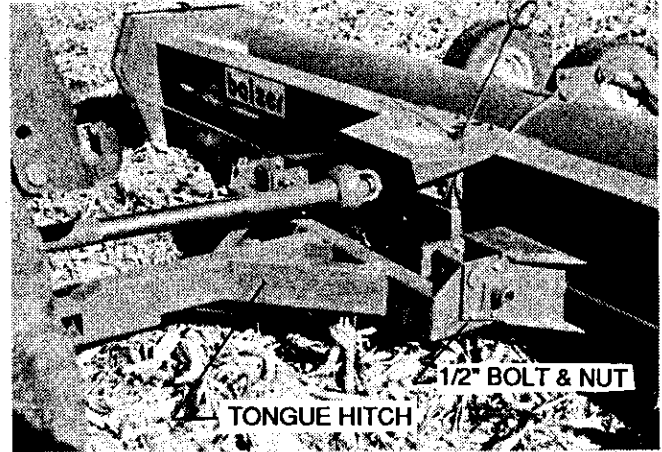

The diagram above shows ASAE standard dimensions. Safe and proper operation is dependant on correct adjustment. Compare these dimensions to your tractor, and make any necessary adjustments. If these dimensions are not possible on your tractor, contact your dealer for assistance.

Pictured above is a pull type unit showing the bolt-on tongue hitch. Mounting hardware is placed in appropriate holes in tongue.

FULL MOUNT (3 point)

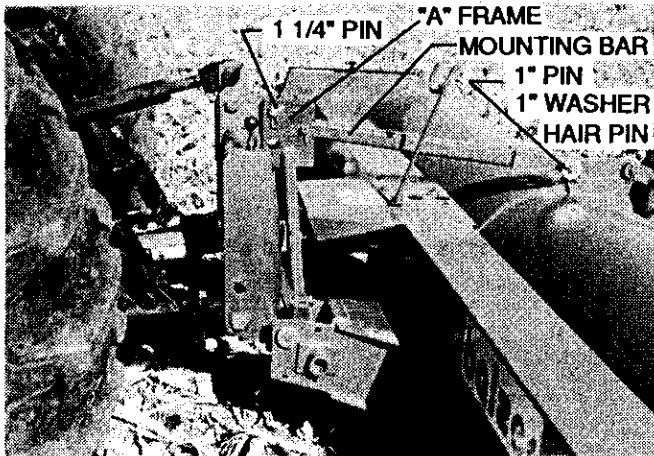

Pictured above is a full mount unit with the required quick hitch. The parts labeled are taped together along with a bag containing the attaching hardware.

PTO DRIVES

Pull type and full mount units require different PTO's. Be sure you have the correct PTO before running the shredder. Measure the PTO and compare the dimensions to the following chart. If it does not match, contact your dealer for the correct PTO.



IMPROPER PTO LENGTH CAN RESULT IN SERIOUS INJURY AND EQUIPMENT DAMAGE.

P/N	TYPE	RPM	Tractor SPLINE	Compressed
				Overall LENGTH
15369	Pull Type	540	1 3/8- 6	53"
15380	Pull Type	1000	1 3/8-21	53"
6985	Pull Type	1000	1 3/4-20	53"
16791	Pull Type	CV1000	1 3/8-21	52 1/4"
17166	Pull Type	CV1000	1 3/4-20	52 1/4"
17490	Mounted	540	1 3/8- 6	31 1/8"
17478	Mounted	1000	1 3/8-21	31 1/8"
17534	Mounted	1000	1 3/4-20	31 1/8"

Operation

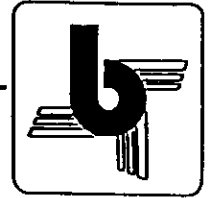

CAUTION: DISENGAGE TRACTOR P.T.O. DRIVE IMMEDIATELY SHOULD EXCESSIVE VIBRATION OCCUR WHILE SHREDDER IS IN OPERATION. SHUT OFF TRACTOR AND REMOVE IGNITION KEYS BEFORE DETERMINING THE CAUSE OF THE VIBRATION.

The tractor should be operated at recommended P.T.O. speed for maximum effectiveness of the shredder.

CAUTION: ALWAYS START UP UNIT SLOWLY AND GRADUALLY BRING UP TO OPERATING SPEED.

The shredder knives must be run a minimum of 2 inches above the ground to prevent excessive wear and knife damage. Position wheels to run in valley between rows.

Do not make sharp turns while tractor P.T.O. is engaged. This practice will damage shredder and tractor drive lines. Constant velocity P.T.O.'s are available which permit sharper turns. Consult with your local dealer for more information.

Never operate shredder with any broken or missing knives, this will cause structural and bearing damage to the unit.

Keep all hinging guard shields in place and free swinging. Replace any broken or bent guards.

FULLY MOUNTED UNITS

IMPORTANT: Reduce travel speed when on a rough or bumpy surface with shredder raised.

ADDITIONAL WEIGHT MAY NEED TO BE ADDED TO THE FRONT OF TRACTOR, TO COUNTERACT THE SHREDDER WEIGHT.

WINDROW

CAUTION: ALWAYS KEEP DEFLECTORS IN PLACE. IF WINGS MUST BE ADJUSTED, ALSO REPOSITION DEFLECTORS TO AVOID UNSAFE OPERATION.

Adjust wings to change the desired windrow width. Loosen the bolts holding the wing clamps and spread wings open. Reposition deflectors to the required width, close wings until they make contact with the deflectors and tighten the wing clamp bolts.

If used as a conventional shredder with the wings wide open, the deflectors must also be adjusted outward. To cover the maximum area.

Service & Lubrication

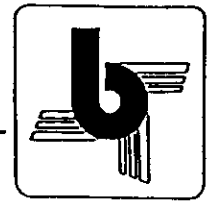

BELT TENSIONING

Loose belts cause heat, glazing and slippage, reducing belt life.

To achieve proper belt tension, use pliers or similar tool and push outside end of spring tightener tab downward to release spring tension. To retighten use screwdriver or similar tool as shown until spring just starts to stretch, then tighten two (2) more notches.

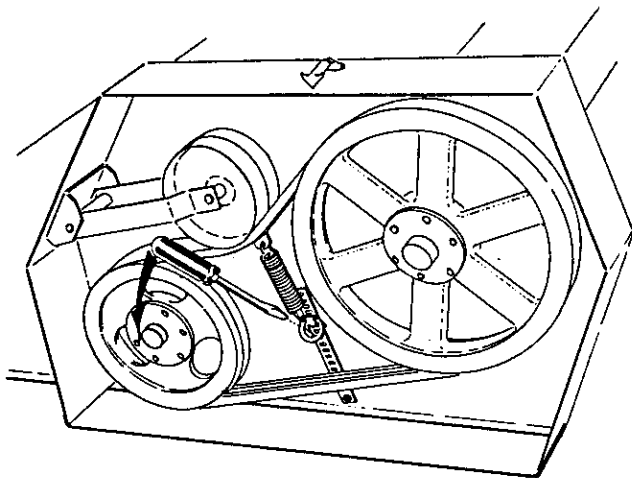

IMPORTANT: Caution must be used when greasing sealed bearings, not to damage bearing seals.

Before greasing, wipe all fittings. Any damaged one's should be replaced.

Use a good grade of MP-2 grease on all fittings. One pump with a hand gun in good condition is recommended on all sealed bearings.

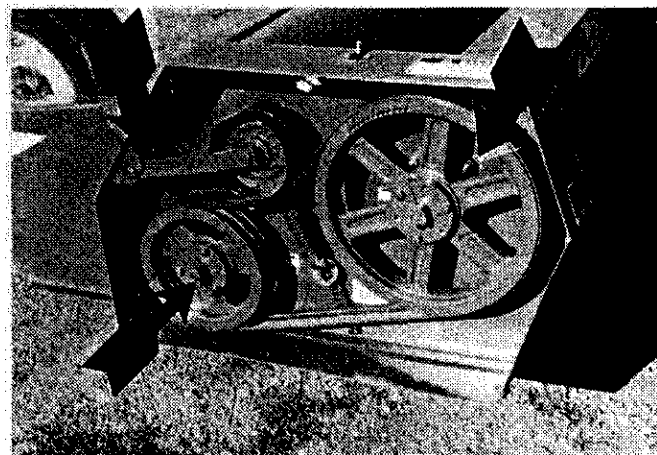

DRIVE SHEAVE ALIGNMENT

Sheave alignment should be checked while unit is being lubricated. If sheaves do become misaligned, first try to determine the cause (i.e. bearing locking collar loose, sheave hub loose). Correct reason for misalignment and then re-align sheaves.

CYLINDER SIDE KNIVES

The side knives have a double edge and may be reversed to cut on the opposite edge. When knife is half worn, it should be reversed to get full use of the knife.

WHEN A KNIFE REQUIRES REPLACEMENT, IT IS NECESSARY TO REPLACE THE KNIFE 180 DEGREES OPPOSITE IT ON THE CYLINDER TUBE. THIS IS NECESSARY TO INSURE PROPER CYLINDER BALANCE AND REDUCE MACHINE WEAR.

PERIODICALLY CHECK ALL HARDWARE FOR PROPER TIGHTNESS ACCORDING TO TORQUE CHART IN THE SET-UP & ASSEMBLY SECTION

- No. 1 -- Idler -- Every 10 hours.
- No. 2 -- Lineshaft Bearings -- Every 10 hours.
- No. 3 -- Outside Cylinder Bearings -- Every 10 hours.

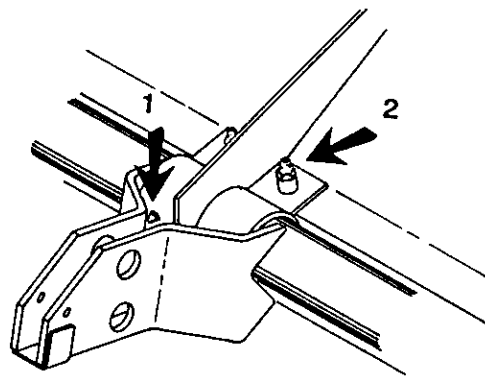

- No. 1 -- Rockshaft -- Daily Prior to using.
- No. 2 -- Inside cylinder bearings -- every 10 hours.

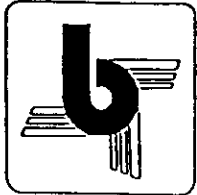

Service & Lubrication

PTO

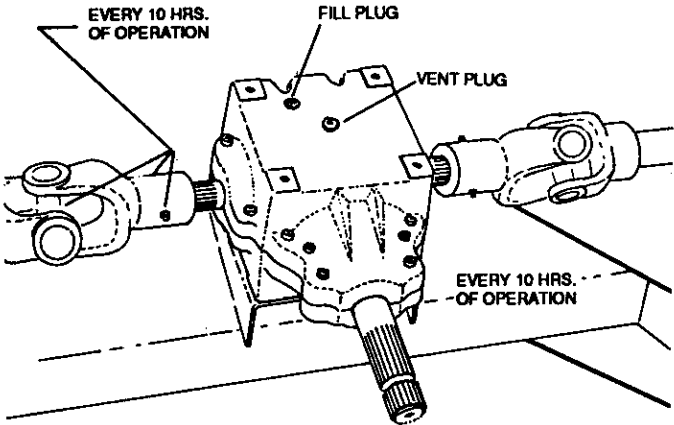

Grease all PTO joints prior to operating and after every eight hours of operation. Some PTO's have a grease fitting for the slide. If your PTO doesn't, the PTO should be pulled apart and the slide cleaned and greased occasionally to insure proper and safe operation.

Check oil level by removing fill plug and reading level on the dipstick. Use a good quality SAE 90 oil with anti-foaming additives.

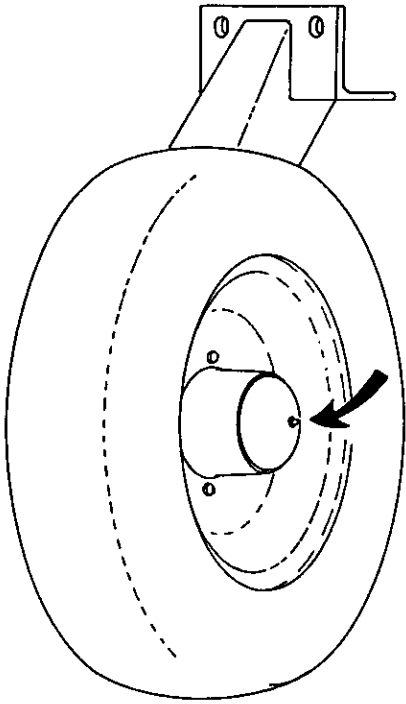

Grease wheel bearings every 50 hours of operation.

Parts

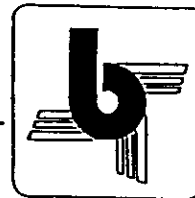

It is the policy of Balzer Mfg. Corp. to constantly improve its products whenever it is practical to do so.

The Balzer Mfg. Corp. must therefore reserve the right to redesign or change its equipment or component parts thereof without incurring the obligation to install or furnish such changes on equipment previously delivered.

INSTRUCTIONS FOR ORDERING PARTS

1. Order all parts by their part number and name. NOTE: All reference to left and right, front and rear apply to the machine as viewed from the rear and facing in direction it normally travels when operating.
2. Parts should never be ordered from item numbers only.
3. Always mention the model and serial numbers found on name plate of unit on which part is to be used. Much delay and confusion can be avoided when correct model and serial numbers are specified on parts order and correspondence.
4. Owners, order all parts thru your local dealer.
5. Dealers must indicate how to ship: whether by truck, rail, freight, express or parcel post.
6. Collect phone calls will not be accepted.
7. Address all orders for parts as follows:

balzer mfg
corp
highway 60 east
mountain lake, mn. 56159
phone (507) 427-3133

INSTRUCTIONS FOR RETURNING PARTS FOR ADJUSTMENT

1. To assure prompt handling of claims, your dealer or distributor should follow standard claim procedure and forward claim within thirty (30) days of any part failure or malfunction believed to be a warranty claim to the Balzer Mfg. Corp. service department for processing.
2. No returned parts will be accepted unless they are transportation prepaid and accompanied by the packing list copy.
3. Parts returned should have a tag attached with senders name and address clearly printed.

Cylinder Assembly

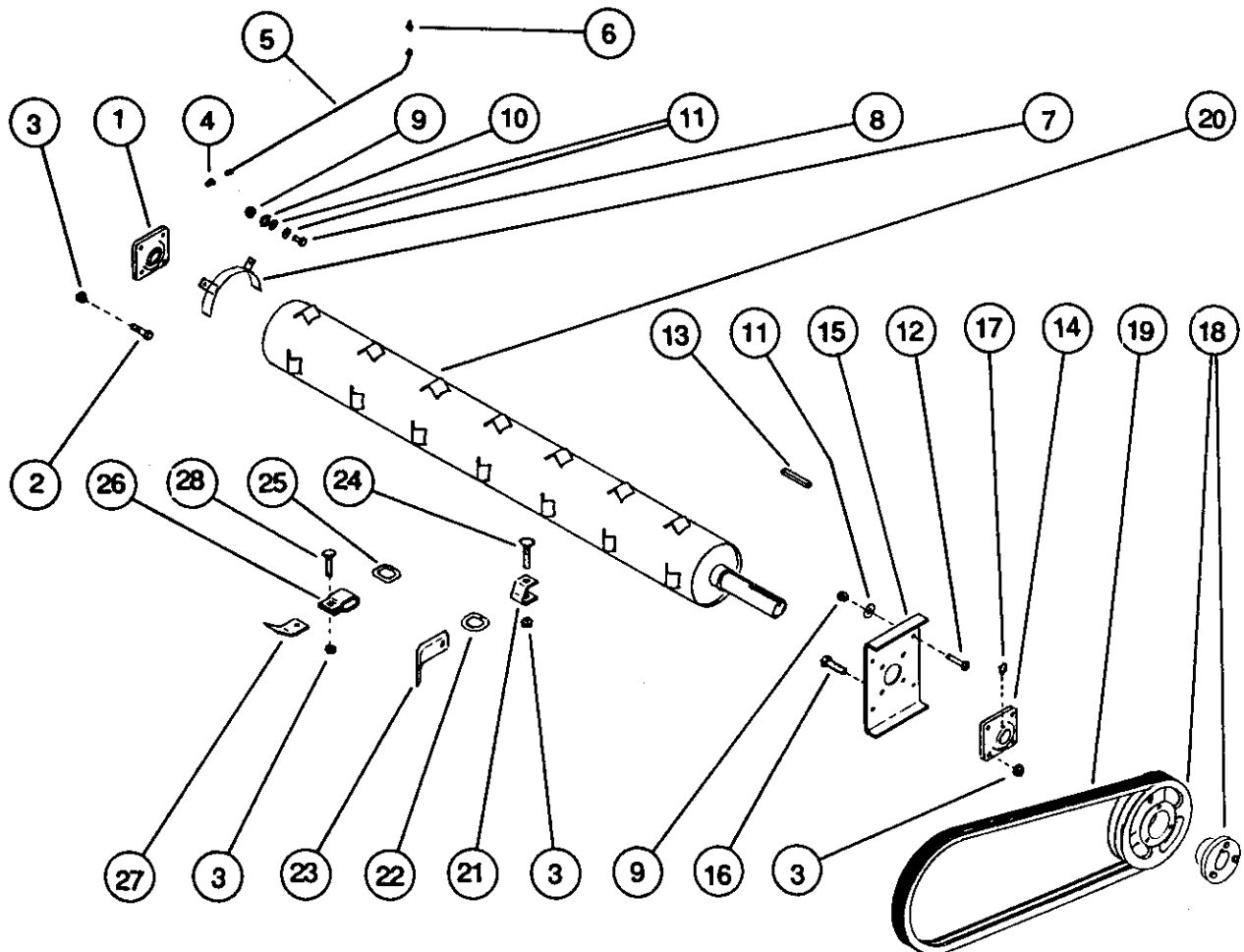
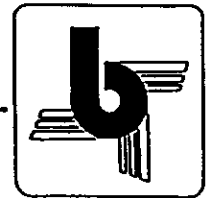

ITEM	P/N	DESCRIPTION	ITEM	P/N	DESCRIPTION
1	12338	Bearing 1 1/2	15	12358	Bearing Stiffener
2	1253	Bolt, Hex Hd 1/2 x 2 1/4	16	1251	Bolt, Hex Hd. 1/2 x 1 3/4
3	2539	Nut, Hex Hd 1/2	17	2291	Zerk 1/8 NPT
4	15306	Fitting 1/8 NPT	18	17191	Sheave 2C-8.0 (540)
	15307	Adaptor 1/4-28 Male		12388	Sheave 2C-10.6 (1000)
5	15304	Grease Tube 22 1/2		12390	Bushing ASBY 1 1/2
6	2291	Zerk 1/8 NPT	19	17192	Belt "C"
7	12366	Grass Ring	20	12345	Cylinder (12 ft.)
8	1186	Bolt, Hex Hd 5/16 x 1 1/4		12475	Cylinder (14 ft.)
9	2475	Nut, Hex Hd 5/16	21	12355	Knife Bracket
		(top lock)	22	12356	D-Ring
10	1635	Lockwasher 5/16	23	12357	Knife
11	1597	Washer, Flat 5/16	24	2530	Bolt, Carriage 1/2 x 3 1/4 GR.5
12	1185	Bolt, Hex Hd 5/16 x 1	25	12295	Ring Attaching
13	2408	Key 3/8 sq. x 2 1/2	26	12296	Hanger, Knife
14	12359	Bearing 1 1/2	27	12297	Cup Knifel
			28	1095	Bolt, Carriage 1/2 x 1 1/2 GR.5

19	12393	Belt C 81 - 1000 RPM
----	-------	----------------------

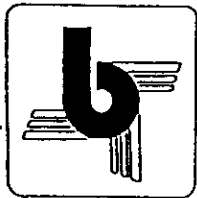

Main Assembly

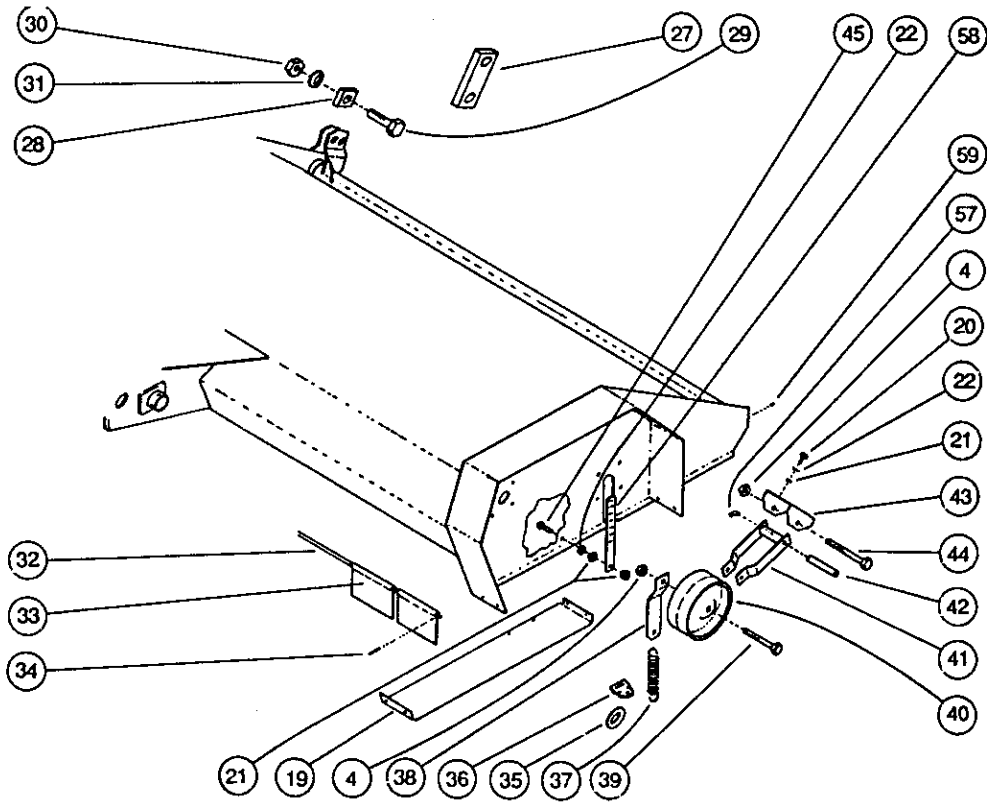
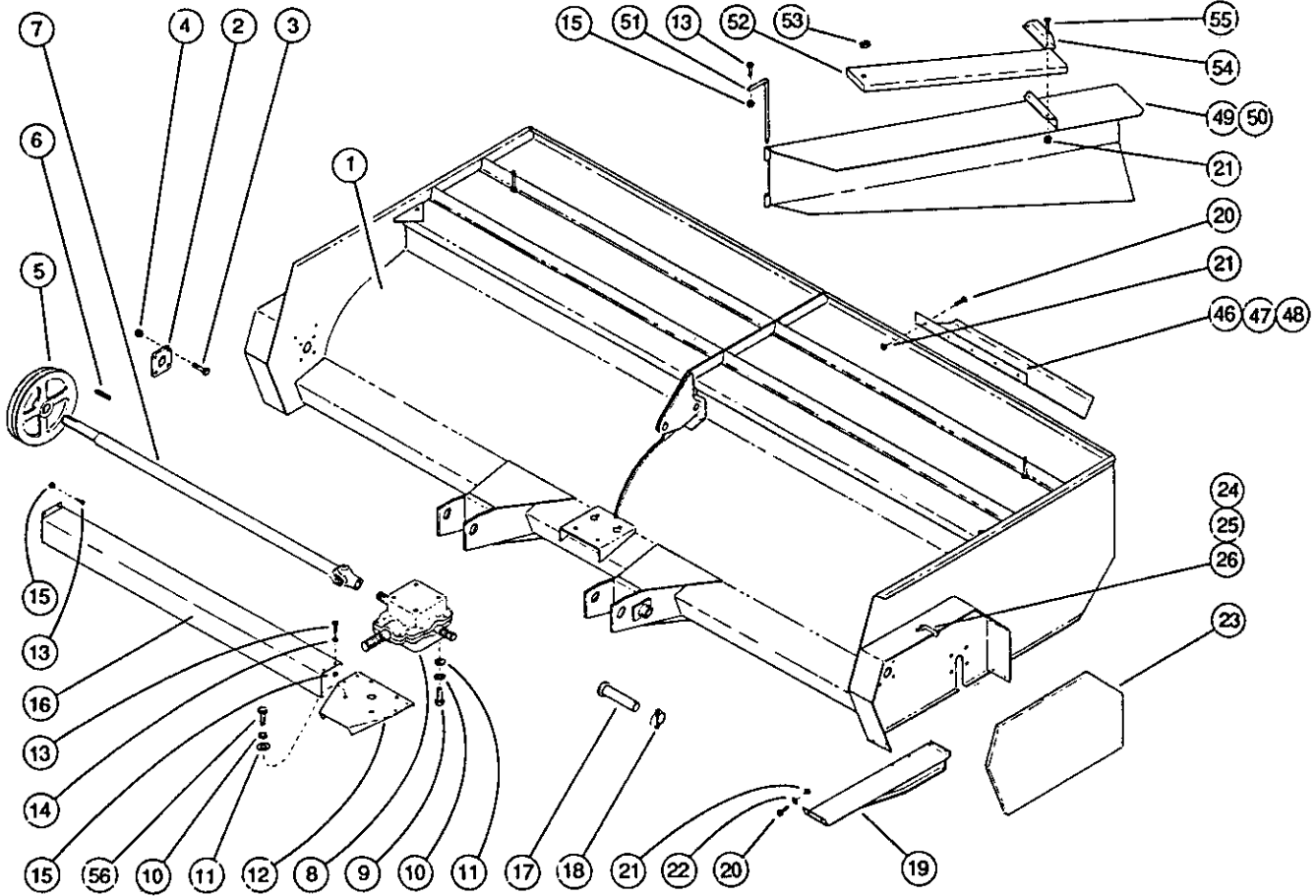

Main Assembly

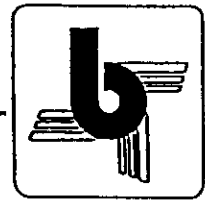

ITEM	P/N	DESCRIPTION	ITEM	P/N	DESCRIPTION
1	17469	Main Housing, 12 ft. Conventional	23	14400	End Shield, R.H.
	17285	Main Housing, 14 ft. Conventional		14401	End Shield, L.H.
	18102	Main Housing, 12 ft. Windrow	24	14403	Hood Latch
	18103	Main Housing, 14 ft. Windrow	25	1161	Bolt, Hex Hd. 1/4 x 5/8
2	16894	Bearing 1 1/2	26	2564	Nut, Hex Hd 1/4 (toplock)
3	1251	Bolt, Hex Hd 1/2 x	27	12427	Cylinder Arm
4	2539	Nut, Hex Hd 1/2	28	12428	Rockshaft Stop
5	12391	Sheave 2C - 16.0	29	1343	Bolt, Hex Hd. 1 x 3
	12390	Bushing ASBY 1 1/2	30	1699	Nut, Hex Hd. 1"
6	2408	Key 3/8 Sq. x 2 1/2	31	1643	Lockwasher 1"
7	12378	Drive Line R.H. 12 ft.	32	12365	Hinge Rod 12 ft.
	12379	Drive Line L.H. 12 ft.		12476	Hinge Rod 14 ft.
	12478	Drive Line R.H., 14 ft.	33	12362	Hinging Guard
	12479	Drive Line L.H., 14 ft.	34	1850	Roll Pin 1/8 x 1
8	17182	Gear Box ASBY 540	35	2003	Bushing, Mach. 1 1/2- 14 GA.
	17472	Gear Box ASBY 1000	36	14476	Spring Tightener
9	1249	Bolt, Hex Hd 1/2 x 1 1/4	37	12401	Spring, Extension
10	1638	Lockwasher 1/2	38	12399	Tightening Plate
11	1600	Washer, Flat 1/2	39	1260	Bolt, Hex Hd. 1/2 x 4
12	17307	Shield, Gear Box	40	12398	Idler Pulley
13	1185	Bolt, Hex Hd. 5/16 x 1	41	12395	Tightener
14	1597	Washer, Flat 5/16	42	12400	Pipe Bushing
15	2475	Nut, Hex Hd 5/16 (top lock)	43	24101	Idler Bracket
16	12422	Shield, Line Shaft, R.H. 12 ft.	44	1263	Bolt, Hex Hd. 1/2 x 5 1/2
	12423	Shield, Line Shaft, L.H. 12 ft.	45	1208	Bolt, Hex Hd. 3/8 x 1 1/2
	12480	Shield, Line Shaft, R.H. 14 ft.	46	18148	Deflector, R.H.
	12481	Shield, Line Shaft, L.H. 14 ft.	47	18149	Deflector, L.H.
17	17299	Pin 1 7/16	48	18150	Deflector
18	2584	Lynch Pin	49	18134	Right Hand Wing
19	18130	End Panel w/Skid, R.H.	50	18135	Left Hand Wing
	18131	End Panel w/Skid, L.H.	51	18143	Wing Hinge Pin
	12404	End Panel, Bottom, R.H.	52	18144	Wing Adjust Arm
	12403	End Panel, Bottom, L.H.	53	2546	Nut, Hex Hd 5/8 (toplock)
20	1206	Bolt, Hex Hd. 3/8 x 1	54	18147	Wing Clamp
21	2496	Nut, Hex Hd 3/8 (toplock)	55	1212	Bolt, Hex Hd. 3/8 x 2 1/2
22	1598	Washer, Flat 3/8	56	1252	Bolt, Hex Hd. 1/2 x 2
			57	2282	Zerk 1/4-28 x 45°
			58	14477	Tightening Bar
			59	2286	Zerk 1/4-28

Gear Box Assembly (1000)

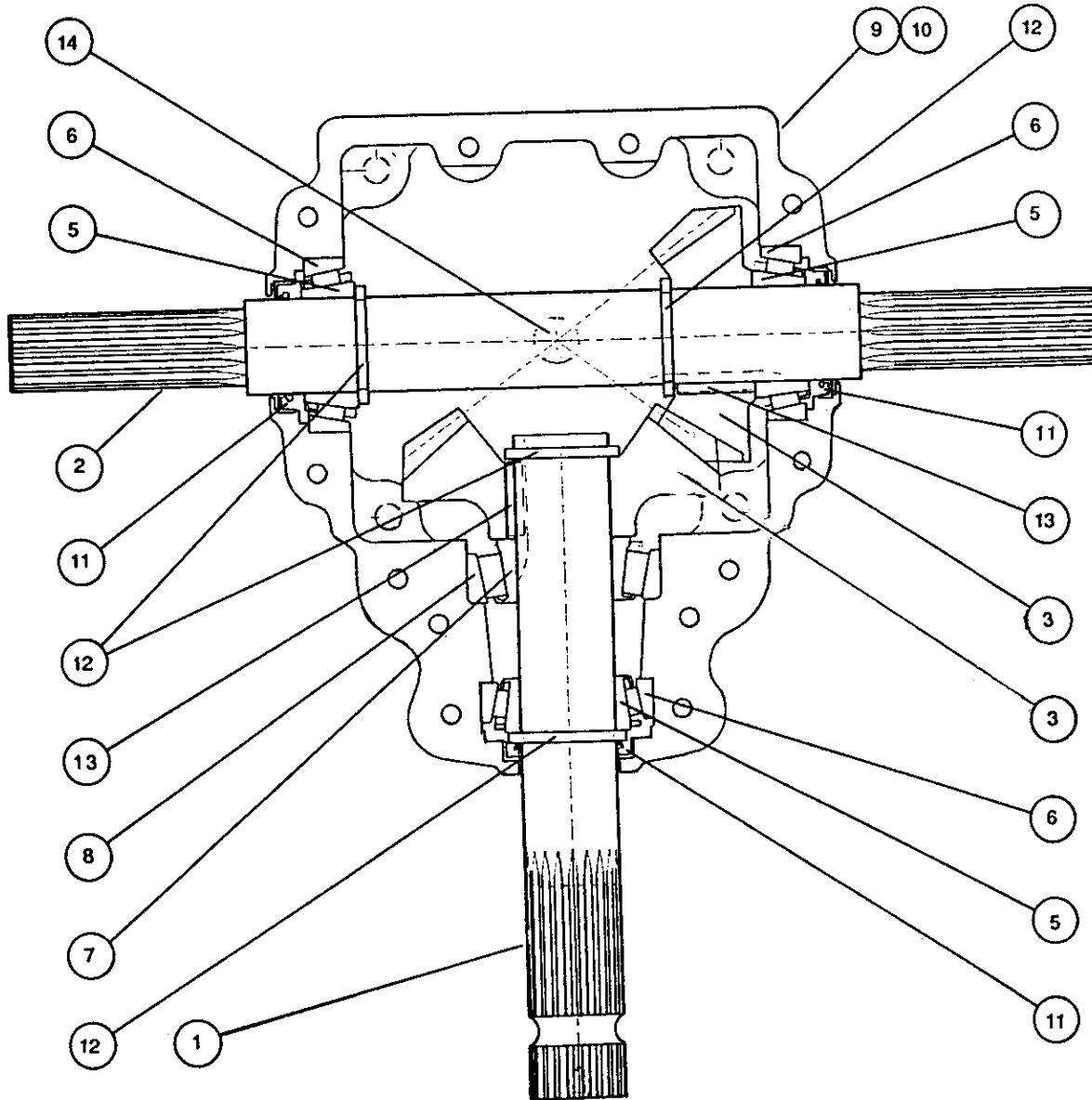
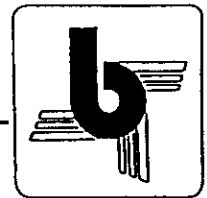

ITEM	P/N	DESCRIPTION	ITEM	P/N	DESCRIPTION
1	17186	Pinion Shaft	12	17204	Retaining Ring
2	17189	Cross Shaft	13	17185	Key 3/8 x 1.45
3	17473	Gear 22T	14	13181	Solid Plug 1/2 NPT
4			15	13038	Bushing 1/8 x 1/2 NPT
5	14322	Bearing Cone, Small	16	13097	Pressure Relief 1/8 NPT -5 PSI
6	11477	Bearing Cup, Small	17	2267	Bolt, SHCS 3/8 x 2 1/4
7	17205	Bearing Cone, Large	18	17190	Dip Stick
8	12886	Bearing Cup, Large	19	8163	Oil SAE 90
9	17184	Casting, Tapped Holes	20	14256	Decal "1000 RPM"
10	17188	Casting, Through Holes			
11	17203	Seal 1 3/4			

Gear Box Assembly (540)

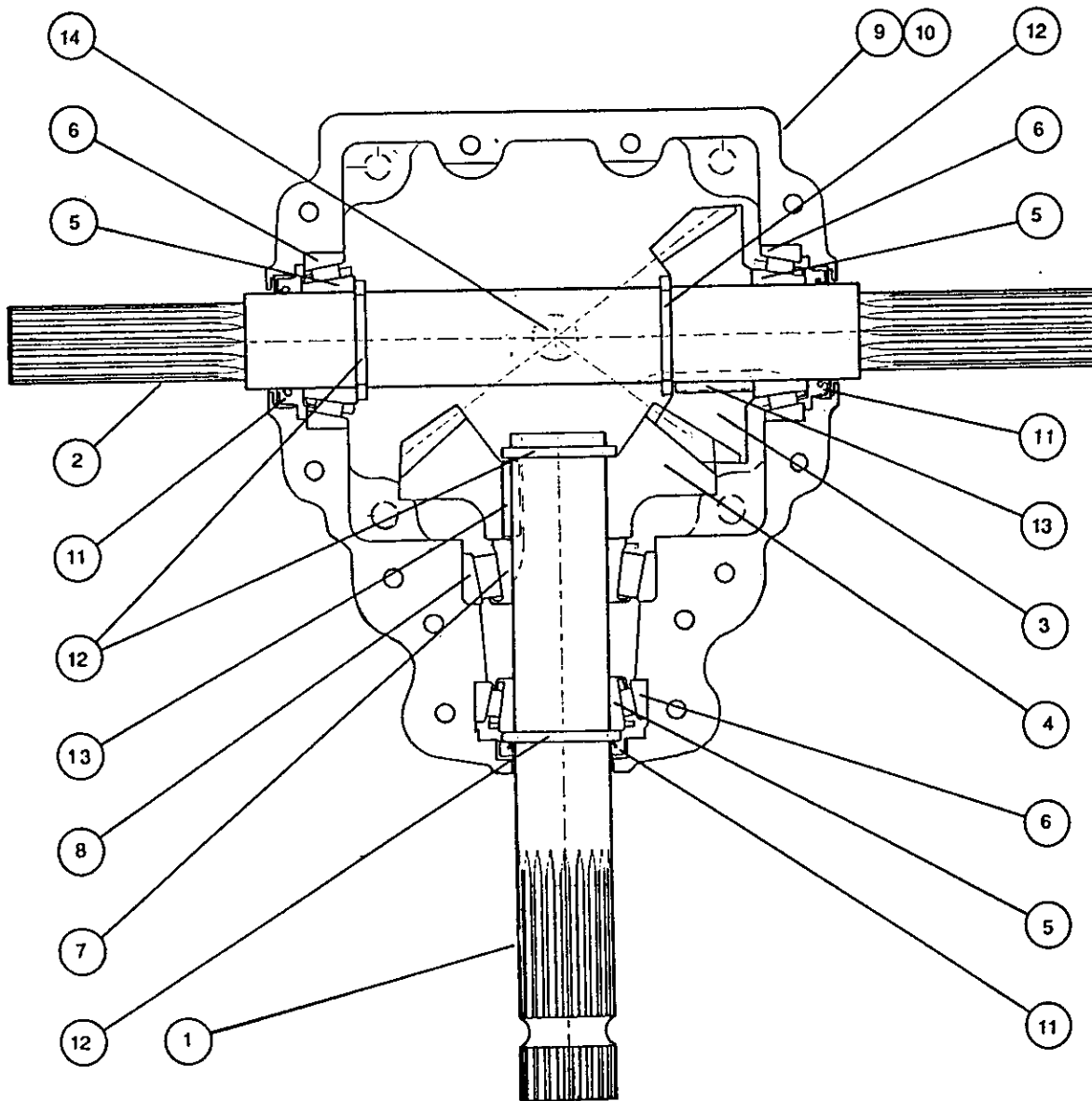

ITEM	P/N	DESCRIPTION	ITEM	P/N	DESCRIPTION
1	17186	Pinion Shaft	12	17204	Retaining Ring
2	17189	Cross Shaft	13	17185	Key 3/8 x 1.45
3	17187	Gear 20T	14	13181	Solid Plug 1/2 NPT
4	17183	Gear 27T	15	13038	Bushing 1/8 x 1/2 NPT
5	14322	Bearing Cone, Small	16	13097	Pressure Relief 1/8 NPT -5 PSI
6	11477	Bearing Cup, Small	17	2267	Bolt, SHCS 3/8 x 2 1/4
7	17205	Bearing Cone, Large	18	17190	Dip Stick
8	12886	Bearing Cup, Large	19	8163	Oil SAE 90
9	17184	Casting, Tapped Holes	20	14255	Decal "540 RPM"
10	17188	Casting, Through Holes			
11	17203	Seal 1 3/4			

PTO-1000 RPM CV-1 3/8-21 TRACTOR SPLINE

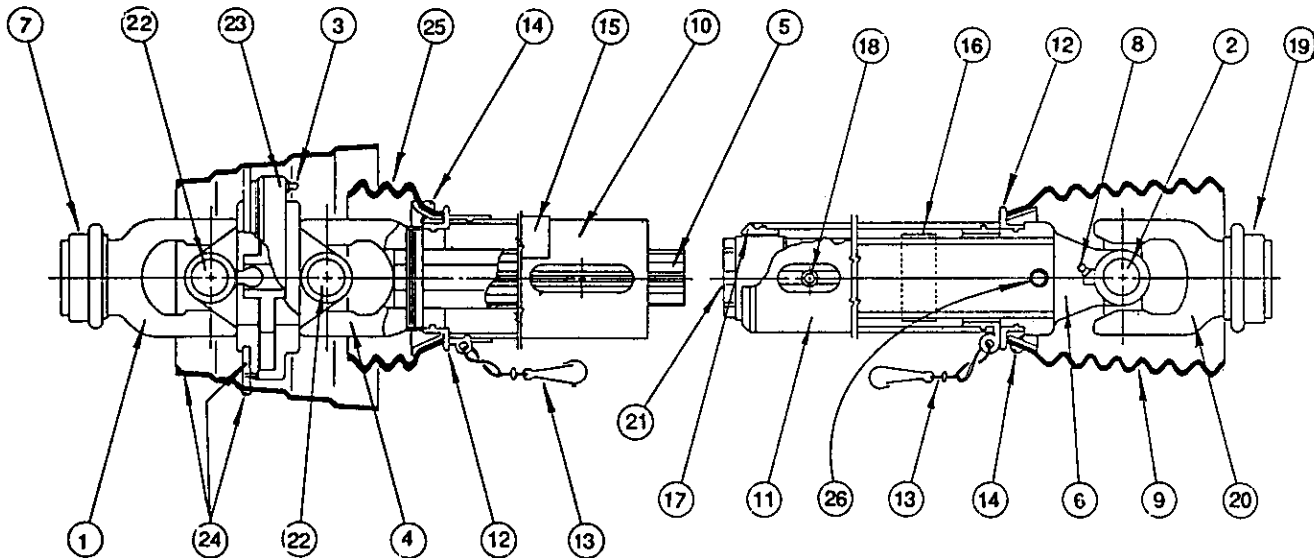
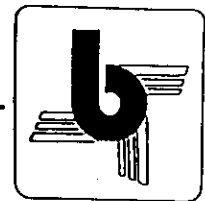

ITEM	P/N	DESCRIPTION	ITEM	P/N	DESCRIPTION
1	17169	Yoke 1 3/8-21 Spline	14	16818	Screw
2	17157	Cross & Bearing Kit	15	16816	Decal - Outer
3	17195	Grease Zerk	16	16817	Decal - Inner
4	17196	Inboard Yoke	17	17171	Support Bearing
5	17198	Inner Profile	18	16820	Grease Zerk
6	17162	Inboard Yoke	19	17173	A.S. Collar Kit
7	17172	A.S. Collar Kit	20	17200	Yoke 1 3/4-20 Spline
8	2293	Grease Zerk 60° M8	21	17199	Profile & Sleeve
9	17163	Shield Cone 7 Rib	22	17197	Cross & Bearing Kit
10	17170	Outer Shield Tube-Oval	23	17194	Double Yoke
11	17175	Inner Shield Tube Rnd	24	17201	CV Cone & Bearing Asby.
12	16814	Bearing Ring	25	17202	Shield Cone- 3' rib
13	16815	Safety Chain	26	17158	Spring Pin M10x90

CV PTO COMPLETE - 16791 (Pull Type Units)

PTO-1000 RPM CV-1 3/4-20

TRACTOR
SPLINE

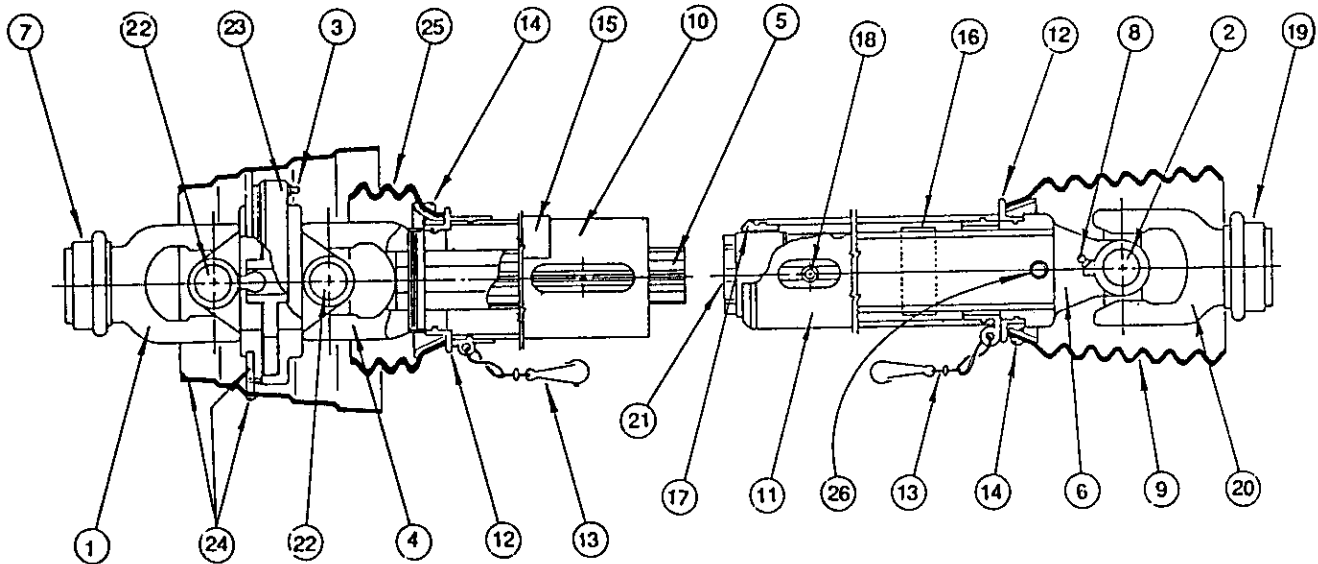
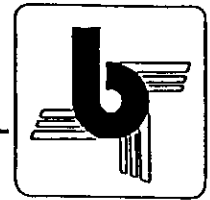

ITEM	P/N	DESCRIPTION	ITEM	P/N	DESCRIPTION
1	16792	Yoke 1 3/4-20 Spline	14	16818	Screw
2	17157	Cross & Bearing Kit	15	16816	Decal - Outer
3	17195	Grease Zerk	16	16817	Decal - Inner
4	17196	Inboard Yoke	17	17171	Support Bearing
5	17198	Inner Profile	18	16820	Grease Zerk
6	17162	Inboard Yoke	19	17173	A.S. Collar Kit
7	17173	A.S. Collar Kit	20	17200	Yoke 1 3/4-20 Spline
8	2293	Grease Zerk 60° M8	21	17199	Profile & Sleeve
9	17163	Shield Cone 7 Rib	22	17197	Cross & Bearing Kit
10	17176	Outer Shield Tube-Oval	23	17194	Double Yoke
11	17175	Inner Shield Tube Rnd	24	17201	CV Cone & Bearing Asby.
12	16814	Bearing Ring	25	17202	Shield Cone- 3' rib
13	16815	Safety Chain	26	17158	Spring Pin M10x90

CV PTO COMPLETE - 17166 (Pull Type Units)

PTO-1000 RPM- 44 Series-1 3/8-21

TRACTOR
SPLINE

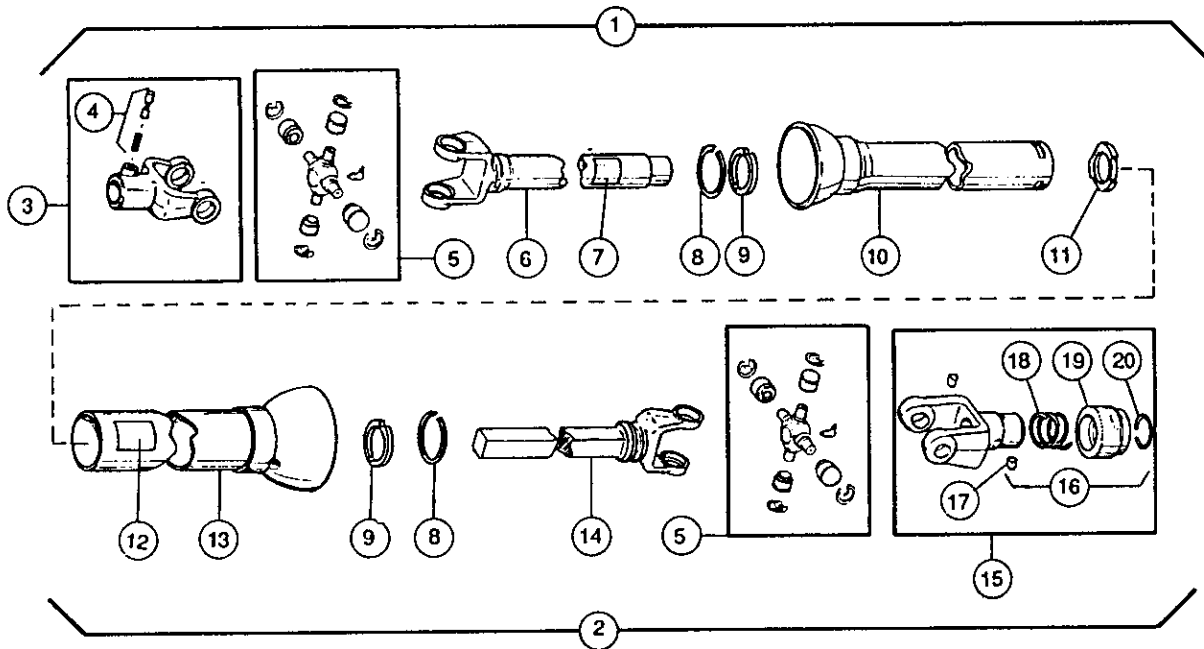
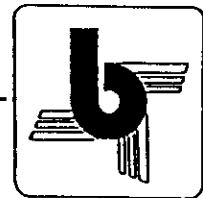

<u>ITEM</u>	<u>P/N</u>	<u>DESCRIPTION</u>	<u>ITEM</u>	<u>P/N</u>	<u>DESCRIPTION</u>
1	15370	Implement Half Asby.	11	12916	Nylon Centralizer
2	15378	Tractor Half Asby.	12	11040	Decal "PTO"
3	15371	Lock Yoke Asby. 1 3/4-20	13	12918	Outer Guard
4	12910	Saf-T-Pin & Spring Kit	14	15376	Yoke & Shaft
5	15372	Repair Kit	15	15379	Lock Yoke Asby 1 3/8-21
6	15373	Yoke & Tube	16	12921	Slide Lock Asby
7	15295	Decal "Danger"	17	12922	Pawl
8	12913	Bearing Retaiier	18	12923	Spring
9	12914	Nylon Bearing	19	12924	Collar
10	15374	Inner Guard	20	12925	Retaining Ring

PTO COMPLETE - 15380 (Pull Type Units)

PTO-1000 RPM- 44 Series-1 3/8-6

TRACTOR
SPLINE

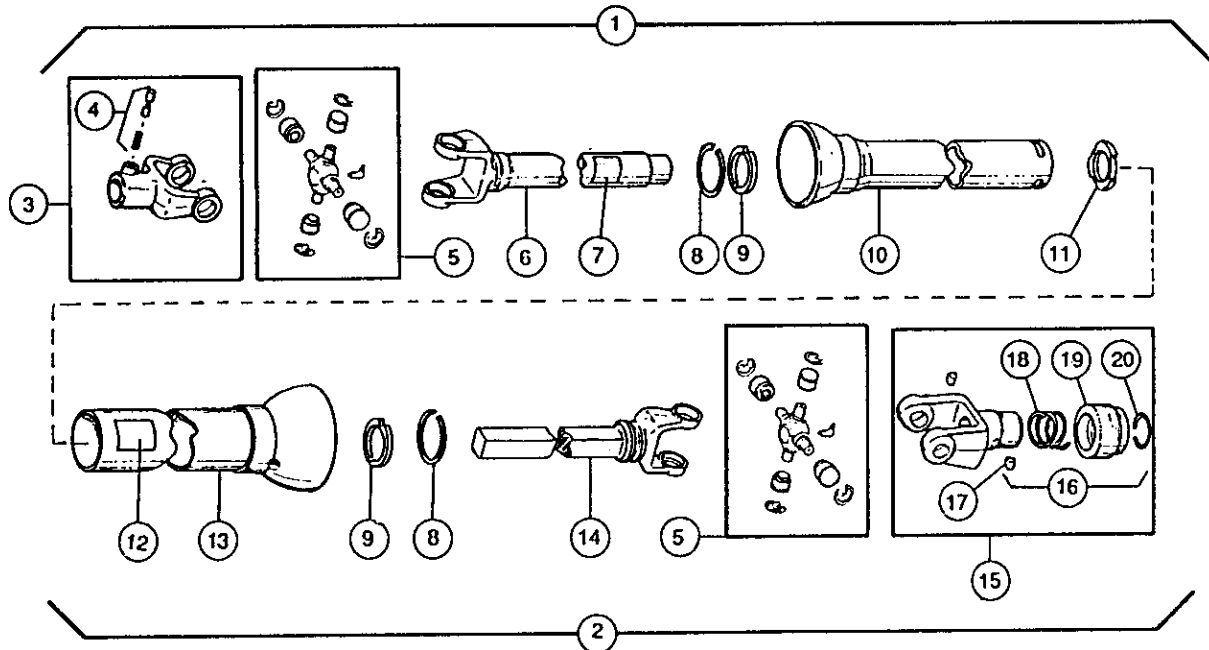
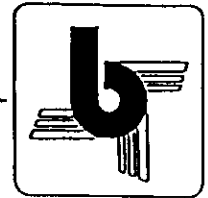

<u>ITEM</u>	<u>P/N</u>	<u>DESCRIPTION</u>	<u>ITEM</u>	<u>P/N</u>	<u>DESCRIPTION</u>
1	15370	Implement Half Asby.	11	12916	Nylon Centralizer
2	15375	Tractor Half Asby.	12	11040	Decal "PTO"
3	15371	Lock Yoke Asby. 1 3/4-20	13	12918	Outer Guard
4	12910	Saf-T-Pin & Spring Kit	14	15376	Yoke & Shaft
5	15372	Repair Kit	15	15377	Lock Yoke Asby 1 3/8-6
6	15373	Yoke & Tube	16	12921	Slide Lock Asby
7	15295	Decal "Danger"	17	12922	Pawl
8	12913	Bearing Retainer	18	12923	Spring
9	12914	Nylon Bearing	19	12924	Collar
10	15374	Inner Guard	20	12925	Retaining Ring

PTO COMPLETE - 15369 (Pull Type Units)

PTO-1000 RPM- 44 Series-1 3/4-20

TRACTOR
SPLINE

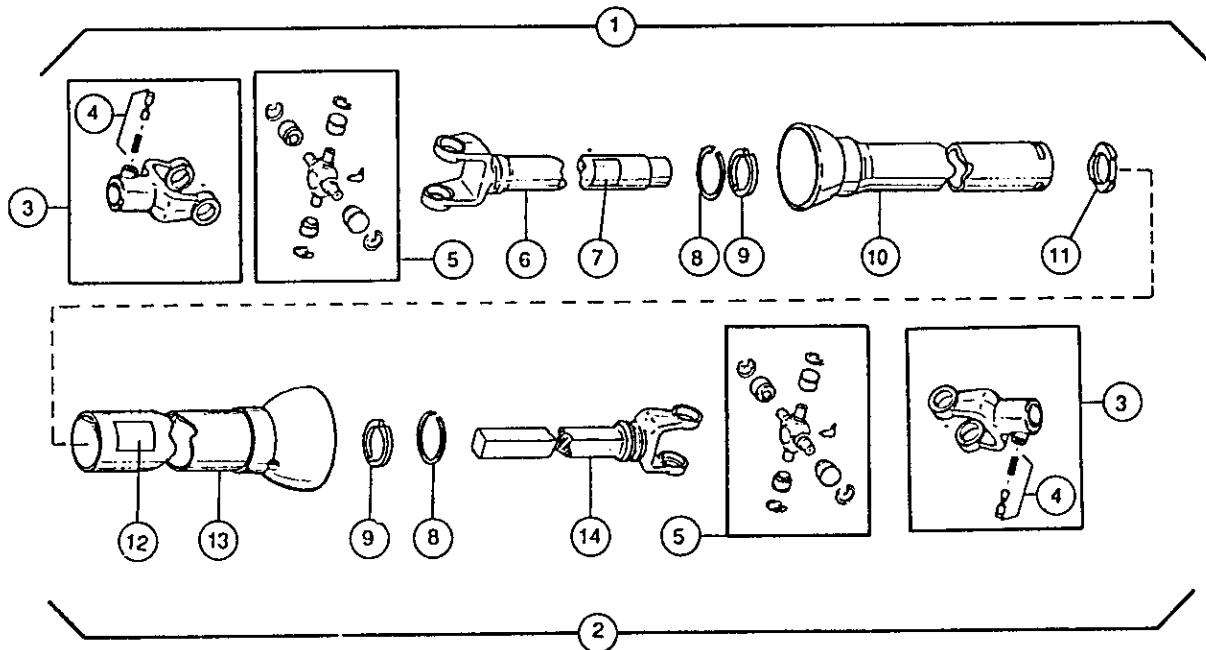
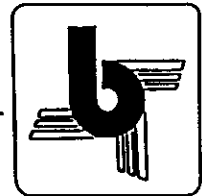

ITEM	P/N	DESCRIPTION
1	15370	Implement Half Asby.
2	6986	Tractor Half Asby.
3	15371	Lock Yoke Asby. 1 3/4-20
4	12910	Saf-T-Pin & Spring Kit
5	15372	Repair Kit
6	15373	Yoke & Tube
7	15295	Decal "Danger"
8	12913	Bearing Retainer

ITEM	P/N	DESCRIPTION
9	12914	Nylon Bearing
10	15374	Inner Guard
11	12916	Nylon Centralizer
12	11040	Decal "PTO"
13	12918	Outer Guard
14	15376	Yoke & Shaft
15	15371	Lock Yoke Asby 1 3/4-20

PTO COMPLETE - 6985 (Pull Type Units)

PTO-1000 RPM-1 3/4-20

TRACTOR
SPLINE

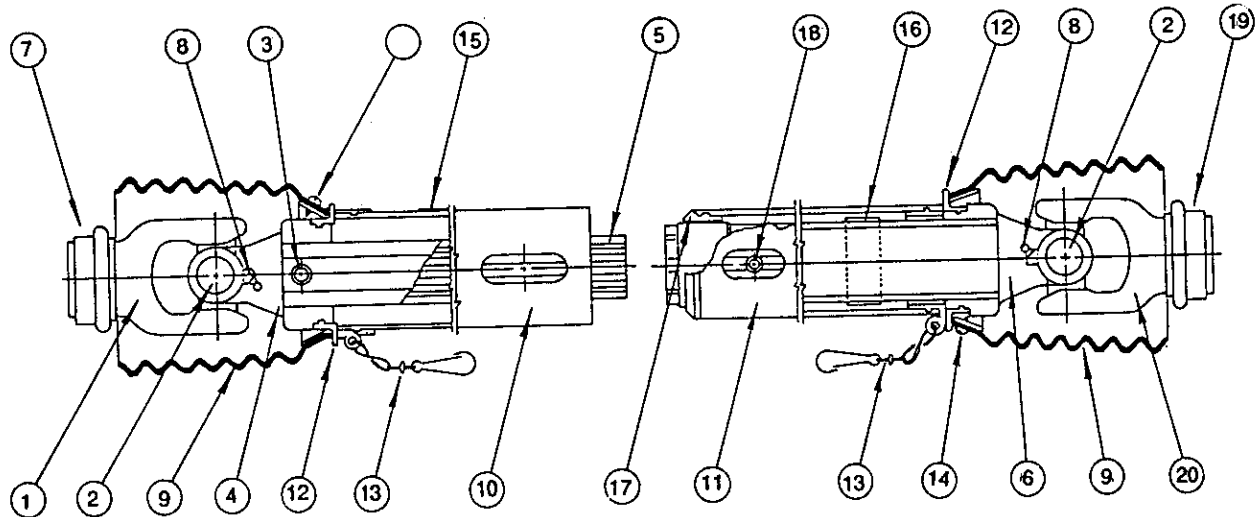
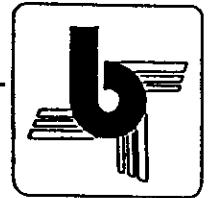

ITEM	P/N	DESCRIPTION	ITEM	P/N	DESCRIPTION
1	17200	Yoke 1 3/4-20 Spline	11	17483	Inner Shield Tube Rnd
2	17157	Cross & Bearing Kit	12	16814	Bearing Ring
3	17158	Spring Pin M10x90	13	16815	Safety Chain
4	17159	Inboard Yoke	14	16818	Screw
5	17480	Inner Profile	15	16816	Decal - Outer
6	17481	Profile, Sleeve and Inner Yoke	16	16817	Decal - Inner
7	17173	A.S. Collar Kit	17	17171	Support Bearing
8	2293	Grease Zerk 60 ° M8	18	16820	Grease Zerk
9	17163	Shield Cone 7 Rib	19	17173	A.S. Collar Kit
10	17482	Outer Shield Tube Oval	20	17200	Yoke 1 3/4-20 Spline

PTO COMPLETE - 17534 (Mounted Units)

PTO-1000 RPM-1 3/8-21

TRACTOR
SPLINE

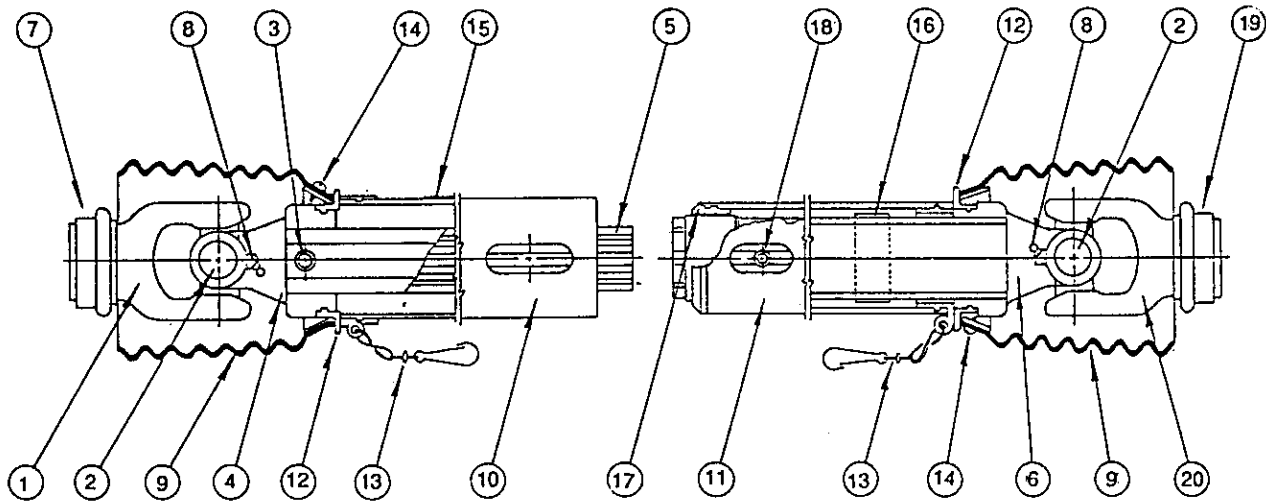
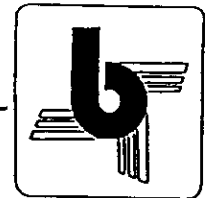

ITEM	P/N	DESCRIPTION
1	17479	Yoke 1 3/8-21 Spline
2	17157	Cross & Bearing Kit
3	17158	Spring Pin M10x90
4	17159	Inboard Yoke
5	17480	Inner Profile
6	17481	Profile, Sleeve and Inner Yoke
7	17172	A.S. Collar Kit
8	2293	Grease Zerk 60 ° M8
9	17163	Shield Cone 7 Rib
10	17482	Outer Shield Tube Oval

ITEM	P/N	DESCRIPTION
11	17483	Inner Shield Tube Rnd
12	16814	Bearing Ring
13	16815	Safety Chain
14	16818	Screw
15	16816	Decal - Outer
16	16817	Decal - Inner
17	17171	Support Bearing
18	16820	Grease Zerk
19	17173	A.S. Collar Kit
20	17200	Yoke 1 3/4-20 Spline

PTO COMPLETE - 17478 (Mounted Units)

PTO-540 RPM-1 3/8-6

TRACTOR SPLINE

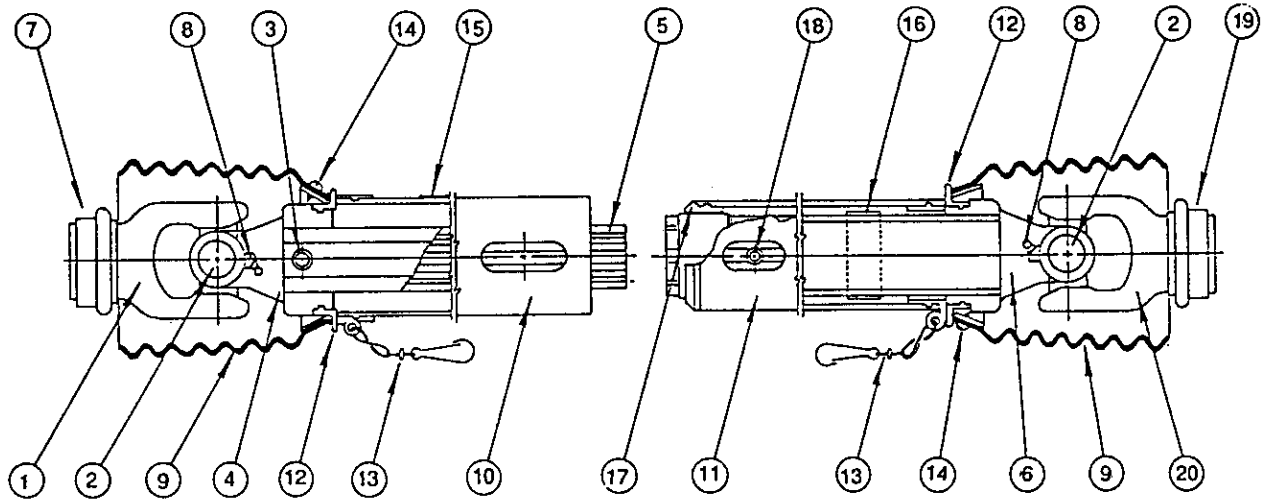

ITEM	P/N	DESCRIPTION
1	17491	Yoke 1 3/4- 6 Spline
2	17157	Cross & Bearing Kit
3	17158	Spring Pin M10x90
4	17159	Inboard Yoke
5	17480	Inner Profile
6	17481	Profile, Sleeve and Inner Yoke
7	17172	A.S. Collar Kit
8	2293	Grease Zerk 60 ° M8
9	17163	Shield Cone 7 Rib
10	17482	Outer Shield Tube Oval

ITEM	P/N	DESCRIPTION
11	17483	Inner Shield Tube Rnd
12	16814	Bearing Ring
13	16815	Safety Chain
14	16818	Screw
15	16816	Decal - Outer
16	16817	Decal - Inner
17	17171	Support Bearing
18	16820	Grease Zerk
19	17173	A.S. Collar Kit
20	17200	Yoke 1 3/4-20 Spline

PTO COMPLETE - 17490 (Mounted Units)

Drive Line 1200

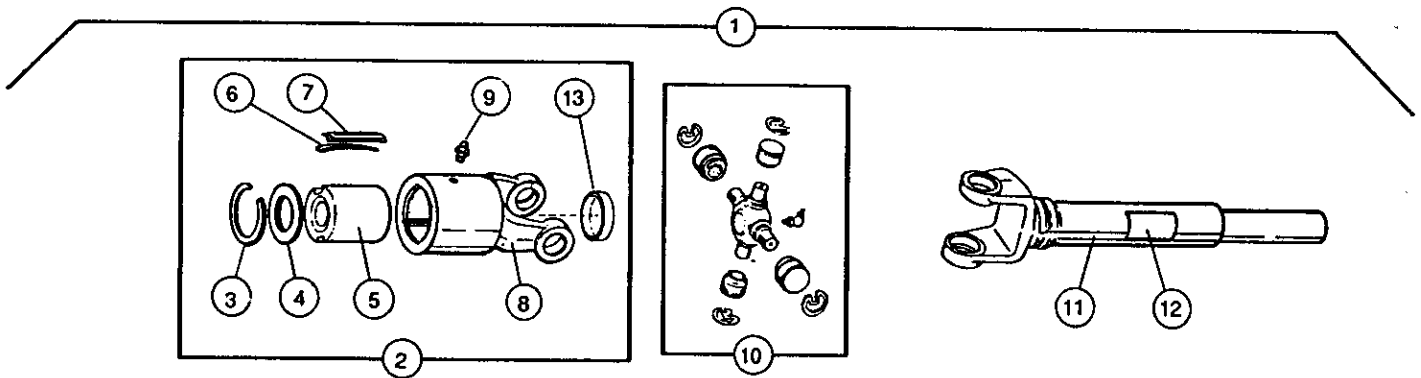
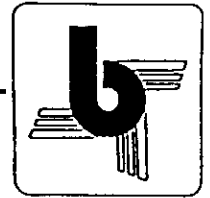

RIGHT HAND

ITEM	P/N	DESCRIPTION
1	12378	Drive Line, R.H.
2	13040	Clutch Asby, R.H.
3	12382	Retaining Ring
4	12381	Washer
5	12380	Inner Sleeve
6	12384	Leaf Spring
7	12383	Drive Key
8	12389	Yoke & Housing, R.H.
9	12385	Zerk Fitting
10	12386	35 PW Kit
11	12387	Drive Line
12	15295	Decal "Danger"
13	15355	Frost Plug 1½

LEFT HAND

ITEM	P/N	DESCRIPTION
1	12379	Drive Line, L.H.
2	13039	Clutch Asby L.H.
3	12382	Retaining Ring
4	12381	Washer
5	12380	Inner Sleeve
6	12384	Leaf Spring
7	12383	Drive Key
8	12906	Yoke & Housing, L.H.
9	12385	Zerk Fitting
10	12386	35 PW Kit
11	12387	Drive Line
12	15295	Decal "Danger"
13	15355	Frost Plug 1½

Drive Line 1400

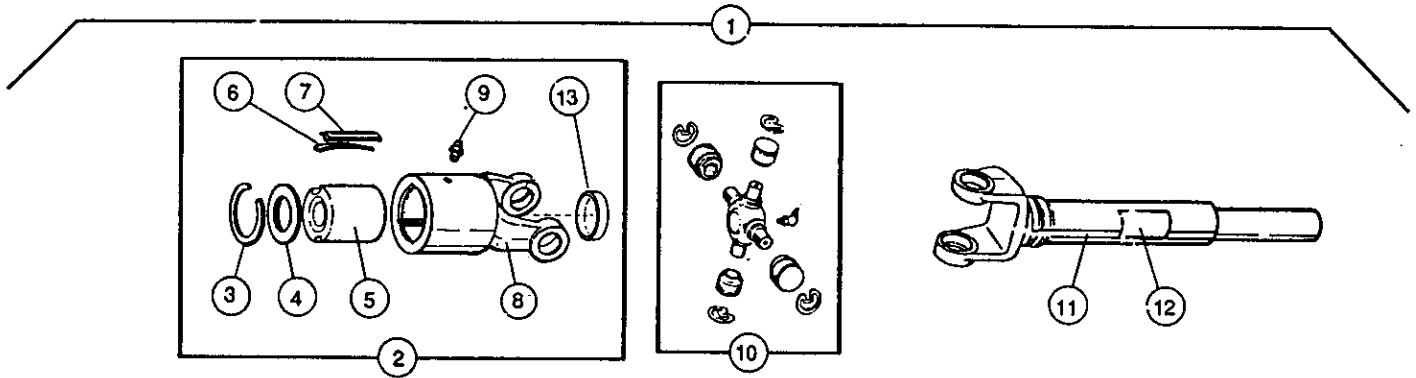
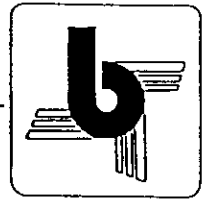

RIGHT HAND

ITEM	P/N	DESCRIPTION
1	12478	Drive Line, R.H.
2	13040	Clutch Asby, R.H.
3	12382	Retaining Ring
4	12381	Washer
5	12380	Inner Sleeve
6	12384	Leaf Spring
7	12383	Drive Key
8	12389	Yoke & Housing, R.H.
9	12385	Zerk Fitting
10	12386	35 PW Kit
11	12477	Drive Line
12	15295	Decal "Danger"
13	15355	Frost Plug 1½

LEFT HAND

ITEM	P/N	DESCRIPTION
1	12479	Drive Line, L.H.
2	13039	Clutch Asby L.H.
3	12382	Retaining Ring
4	12381	Washer
5	12380	Inner Sleeve
6	12384	Leaf Spring
7	12383	Drive Key
8	12906	Yoke & Housing, L.H.
9	12385	Zerk Fitting
10	12386	35 PW Kit
11	12477	Drive Line
12	15295	Decal "Danger"
13	15355	Frost Plug 1½

Weasler Overrunning Clutches - Part #'s 13039, 13040, 24146, 24147

**Left Hand Pictured*

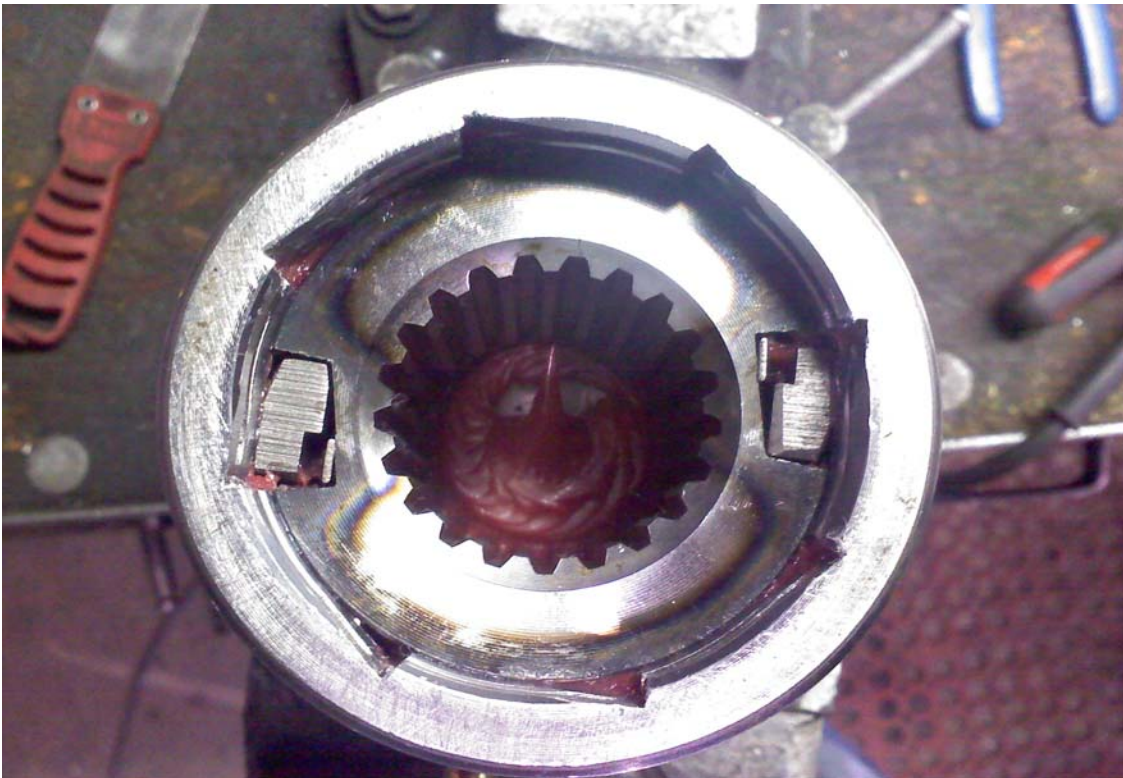
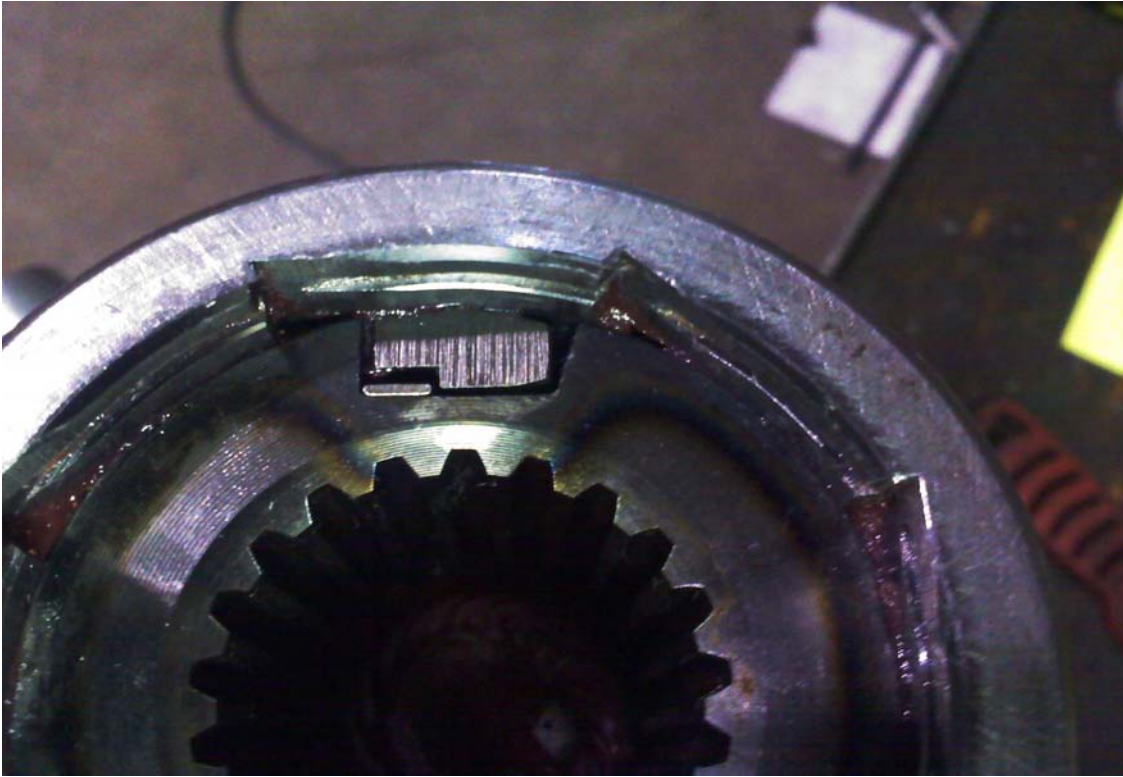

Jack Assembly

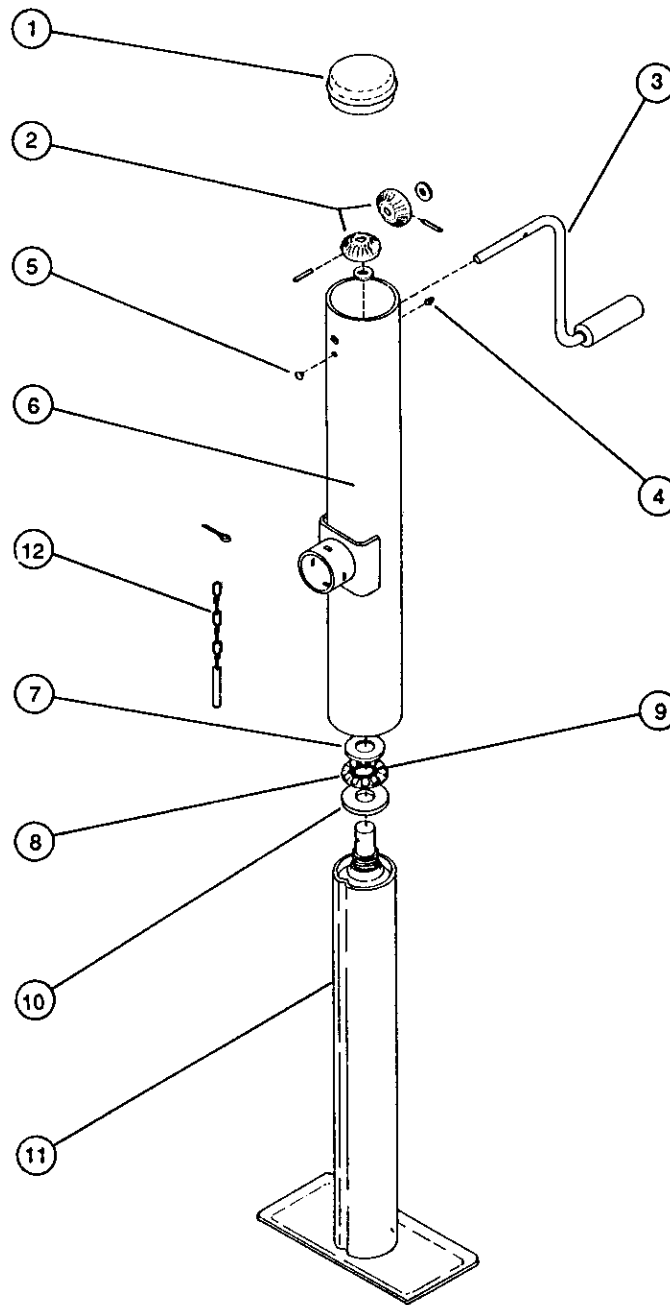

COMPLETE JACK ASBY (10517)

<u>ITEM</u>	<u>P/N</u>	<u>DESCRIPTION</u>	<u>ITEM</u>	<u>P/N</u>	<u>DESCRIPTION</u>
1	13047	SW Tube Cap	8	13053	Ball & Cage Bearing
2	13046	Bevel Gear Kit	9	13052	Felt Spacer
3	13045	Crank Assembly	10	13051	Support Washer
4	2288	Zerk 3/16 Drive-In	11	13050	Inner Tube Assembly
5	13048	Rubber Grommet	12	13049	Pull Pin & Chain
6	13055	Outer Tube Asby	13	13172	Drive Screw
7	13054	Thrust Washer			

Tongue & Full Mount Parts

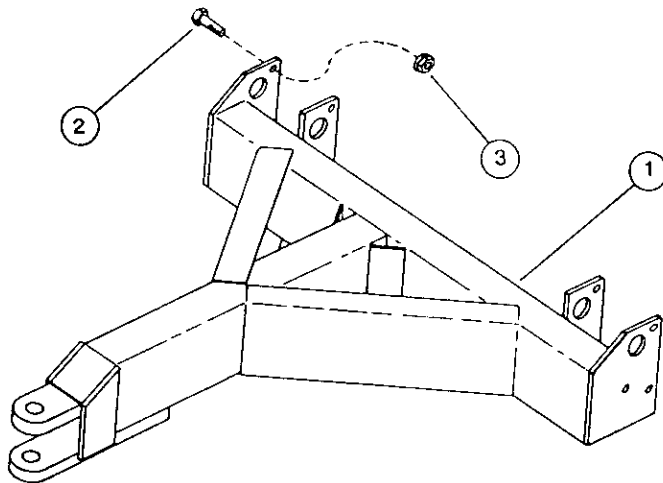
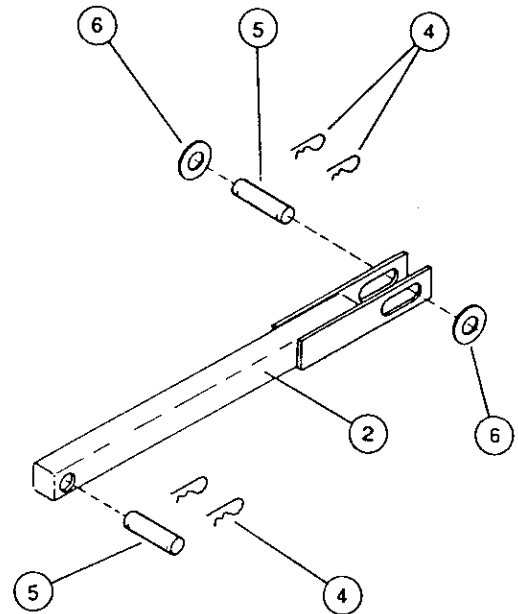
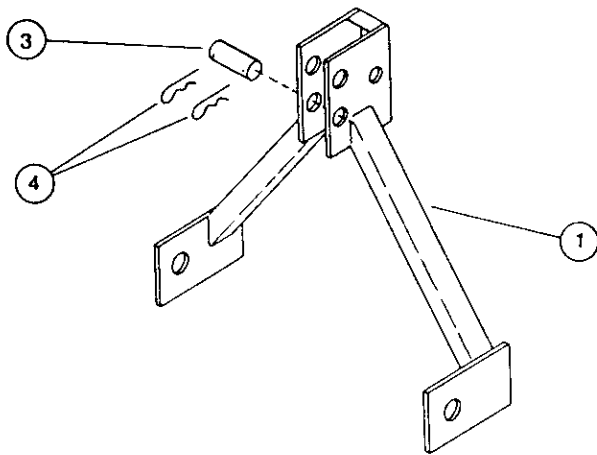
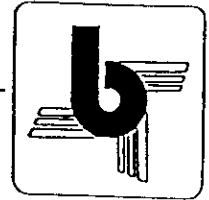

PULL TYPE TONGUE

ITEM	P/N	DESCRIPTION
1	17393	Hitch
2	1250	Bolt, Hex Hd 1/2 x 1 1/2
3	2084	Nut, Hex Hd 1/2

FULL MOUNT

ITEM	P/N	DESCRIPTION
1	17294	"A" Frame
2	17300	Mounting Bar
3	17303	Pin 1/4"
4	11059	Hair Pin Cotter 5/32
5	17305	Pin 1"
6	1605	Washer, Flat 1"

Wheel Assembly

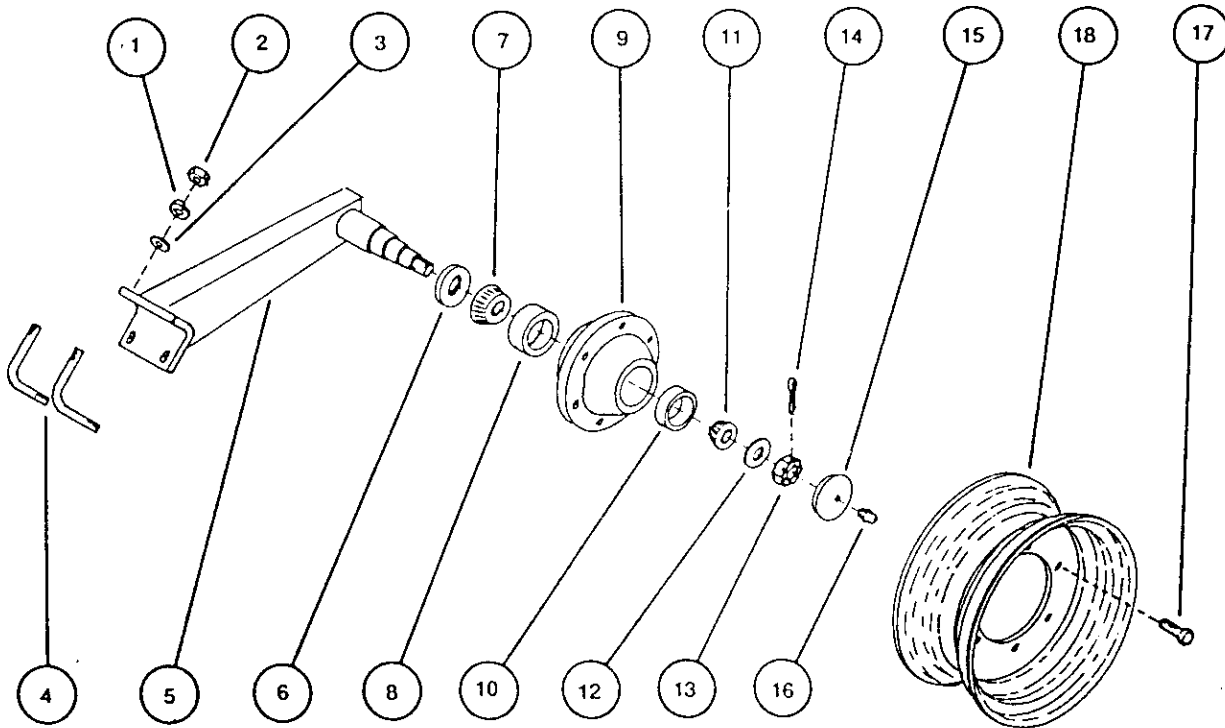
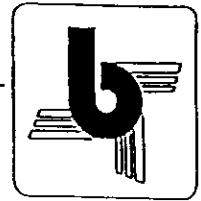

<u>ITEM</u>	<u>P/N</u>	<u>DESCRIPTION</u>	<u>ITEM</u>	<u>P/N</u>	<u>DESCRIPTION</u>
1	1640	Lockwasher 5/8	10	6663	Cup, Outer
2	1696	Nut, Hex Hd 5/8	11	6665	Cone, Outer
3	1602	Washer, Flat 5/8	12	1605	Washer, Flat 1"
4	15354	Bolt, Mounting Bracket	13	1754	Nut, Hex Castle 1"
5	15351	Wheel Arm	14	2045	Cotter Pin 5/32 x 1 1/2
6	6572	Seal	15	12442	Hub Cap w/Zerk
7	6573	Cone, Inner	16	2286	Zerk 1/4 - 28
8	6574	Cup, inner	17	9089	Wheel Bolt
9	12441	Hub 6-Bolt	18	8125	Wheel 15x6 6-Bolt

COMPLETE WHEEL ASSEMBLY (15349)

Center Divider, Disc Hitch & Ratchet Jack

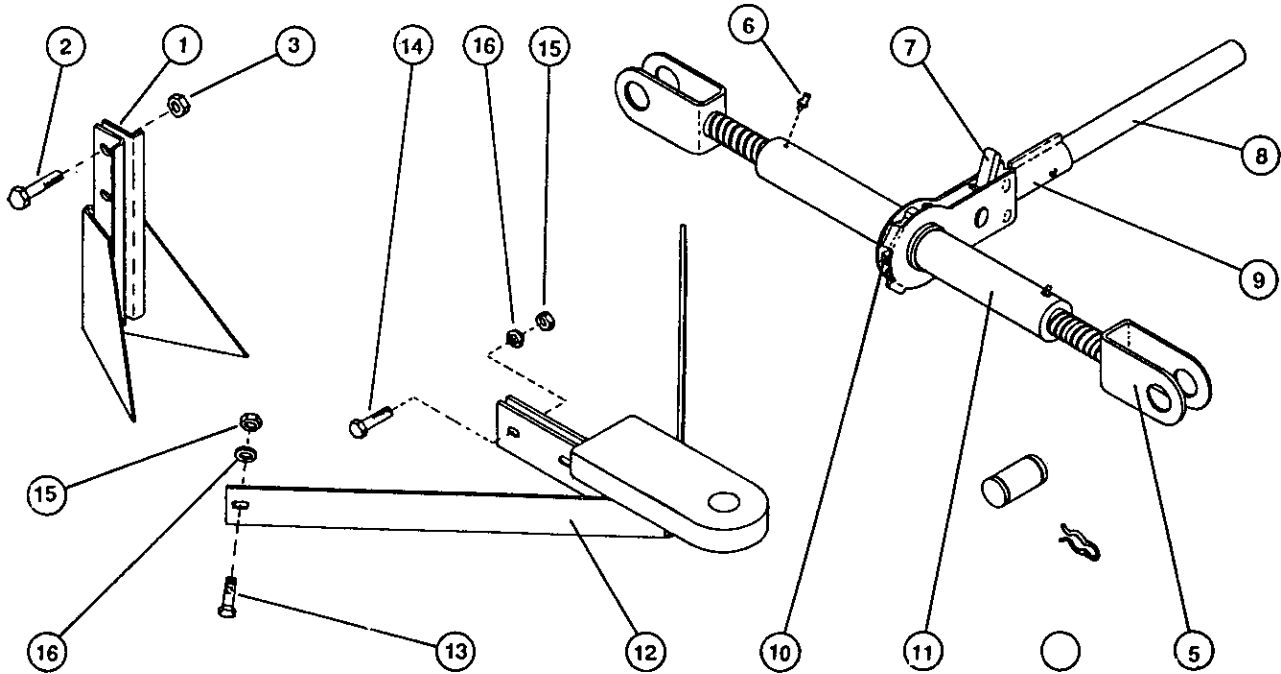
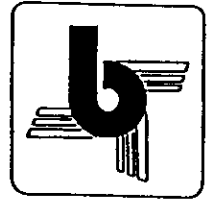

ITEM	P/N	DESCRIPTION	ITEM	P/N	DESCRIPTION
1	24021	Center Divider	9	12955	Ratchet Housing
2	1250	Bolt, Hex Hd ½ x 1½	10	12953	Ratchet
3	2539	Nut, Hex Hd ½ (Top Lock)	11	12952	Main Housing
4	1600	Washer, Flat ½	12	12438	Disc Hitch
5	12951	Screw Yoke Asby	13	1249	Bolt, Hex Hd ½ x 1¼
6	2289	Grease Fitting	14	1251	Bolt, Hex Hd ½ x 1¾
7	12954	Ratchet Finger	15	1694	Nut, Hex Hd ½
8	12956	Handle	16	1638	Lockwasher ½

CENTER DIVIDER COMPLETE (24027)
RATCHET JACK COMPLETE (12267)
DISC HITCH COMPLETE (12269)