



PM-MST-2

March 16, 2015
ECR: 101408R

BALZER



MAGNUM SLURRY TANKS (TRIDEM) PARTS MANUAL

Serial Number: _____

Date of Purchase: _____

Purchased From: _____

Dealer's Address: _____

Dealer's Telephone: _____

INDEX

Company Statements	1	Wheels	33
Accuracy Statement	1	Spindle and Wheel Hub	34
Instructions for Ordering Parts	1	Tires	36
Instructions for Receiving Replacement Parts	1	Braking System	37
Contact Information	1	Disc Brake Assembly	38
Safety Statement	3	Hydraulic Brake Return	39
Mandatory Shut Down Procedure	4	Electrical	41
Additional Safety Reminders	5	Light Location	42
Personal Safety	5	Lighting Assemblies	43
Towing Safety	5	Wiring Diagram	45
Operation Safety	6	Slurry Tank	47
Hydraulic Safety	7	Float	48
Safety Signs and Decals	7	Top Caps and Seals	49
Technical Data	9	Discharge Tube	50
Specifications	10	Recirculation Connection	51
Main Components	12	Slurry Pump	53
Frame	13	Pump System	54
Tridem Frame	14	Pump	55
Tridem Frame Assembly	15	Hydraulic Drive	58
Tongue Assembly	16	Discharge System	59
Bull Pull Hitch Inserts	17	Discharge System with Flow Control	60
Suspension	19	Rite Rate Flow Control	61
Tridem Suspension Hydraulics	20	Decals	63
Tridem Suspension Hydraulic Ports	21		
Tridem Suspension Hydraulic Fittings	22		
Tridem Suspension Hydraulic Connections	23		
Steering	25		
Straight Axle Assembly	26		
Steering Axle Assembly	27		
Steering Hydraulics	30		

Accuracy

Balzer Incorporated is dedicated to providing the most reliable and durable agricultural related products available. We have made every attempt to provide the most accurate and readily understandable information on our equipment. Due to our continuing efforts to produce the best products available, updates and improvements to our equipment may precede updates to this and other manuals. Therefore, the contents of this manual are based on the information in effect at the time of publication and are subject to change without notice.

It is the policy of Balzer Incorporated to constantly improve its products whenever it is practical to do so. Therefore, Balzer Incorporated reserves the right to redesign or change its equipment or component parts thereof without incurring the obligation to install or furnish such changes on equipment manufactured prior to date of redesign or change.

Instructions for Ordering Parts

To enable our customer service department to provide you with the correct replacement parts promptly, follow the ordering instructions as listed below:

1. Identify your equipment by serial number whenever possible
2. Use the illustrations and parts lists included in this manual to correctly identify the parts needed
3. Use Part Numbers and Descriptions from the illustrations and parts lists included in this manual
4. Include the appropriate quantity of each replacement part needed
5. Owners must order all replacement parts through your local dealer
6. All parts being replaced under warranty are to have a Return Merchandise Authorization (RMA)
7. All parts being replaced under warranty are to be returned to Balzer Incorporated within 15 days of receiving the replacement parts
8. Dealers must indicate their company name, shipping point, mailing address (if different than shipping point), and desired shipping method (freight, express, parcel, or other handling)

Instructions for Receiving Replacement Parts

Instructions for dealers and customers (when applicable):

1. Dealers must inspect all parts immediately when received
2. Shortages or damages should be noted by the carrier's agent at the time parts are accepted by the dealer
3. Shipper's responsibility ceases upon delivery of shipment to the customer in good order
4. Claims for damage, loss, or malfunction are to be reported within 30 days for warranty consideration
5. All parts being returned must have a Return Merchandise Authorization (RMA), a copy of the original packing list, and shipping prepaid

Contact Information

Telephone Numbers	Toll-Free:	(800) 795-8551 (800) 727-3133
	Outside North America:	(507) 427-3133
	Fax:	(507) 427-3640
Replacement Parts	Ken Classen	Ext. 104
	Doug Wellman	Ext. 108
Service	Dave Bennett	Ext. 134
Mailing/Shipping	Balzer Inc.	
	County Road 27 East	
	PO Box 458	
	Mountain Lake, MN 56159	
Website	www.balzerinc.com	

BALZER

Safety

The following Safety Alert Symbols mean **ATTENTION! BECOME ALERT! YOUR SAFETY IS INVOLVED!** They stress an attitude of “**HEADS UP FOR SAFETY**” and can be found throughout this manual and on the equipment itself.

BEFORE YOU ATTEMPT TO OPERATE, MAINTAIN, OR SERVICE THIS EQUIPMENT, READ AND STUDY THE FOLLOWING SAFETY INFORMATION. IN ADDITION, MAKE SURE THAT EVERY INDIVIDUAL WHO OPERATES, WORKS WITH, OR OTHERWISE USES THIS EQUIPMENT IS FAMILIAR WITH THESE SAFETY PRECAUTIONS.

Our company **ALWAYS** takes operator safety into consideration when designing its machinery, guards, and exposed moving parts for operator protection. However, some areas can **NOT** be guarded or shielded in order to assure proper operation. In addition to this manual, decals on the machine warn of further danger and should be read and observed closely.

READ and **FOLLOW** the instructions on all decals.

REMEMBER it is the owner’s responsibility for communicating all information on the safe use and proper maintenance of this machine! This includes providing understandable interpretation of these instructions for operators who are not fluent in reading or understanding English.

	DANGER	DANGER indicates an imminently hazardous situation which if not avoided will result in serious injury or death or irreparable damage to the machine.
---	---------------	---

	WARNING	WARNING indicates a potentially hazardous situation which if not avoided may result in serious injury or death or moderate to severe damage to the machine.
--	----------------	--

	CAUTION	CAUTION indicates a potentially hazardous situation which if not avoided may result in minor to moderate injury or minor to moderate damage to the machine.
--	----------------	--

Mandatory Safety Shutdown Procedure

BEFORE cleaning, adjusting, lubricating, or servicing this equipment:

1. Remove the ignition key from the power unit engine.
2. Make sure ALL movement throughout this equipment has ceased! **ONLY** when you have taken these precautions can you be sure it is safe to proceed. Failure to follow the above procedure may lead to serious injury or death.
3. Properly attach the jack to this equipment and raise up to transfer weight to the jack.
4. Keep the hitch pin attached to help prevent this equipment from moving.
5. Disconnect the PTO shaft from the power unit.

Additional Safety Reminders

USER/OPERATOR SAFETY PRACTICES are included in this manual and are intended to promote SAFE OPERATION of this equipment.

These guidelines do not preclude the use of good judgment, care, and common sense as may be indicated by the particular job site work conditions.

It is essential that all operators be physically and mentally free of any mind altering drugs and chemicals and thoroughly trained in the safe operation of this equipment. Such training should be presented completely to all new operators and **NOT** condensed for those claiming previous experience.

FOR ILLUSTRATION PURPOSES ONLY some photographs and images in this manual may show doors, guards, and shields open or removed. **BE SURE** all doors, guards, and shields are in their proper operating positions **BEFORE** operating this equipment. **NEVER** operate this equipment with any guards or shields damaged or not in place. **REPLACE** any damaged or missing guards and shields.

KEEP HANDS AND FEET AWAY FROM ALL MOVING PARTS!

The operator **MUST** know the capabilities and work applications for this equipment and operate it at speeds slow enough to ensure complete control at all times. When working on uneven ground or near the edge of roadbeds there is no substitute for good judgment and only operators with sufficient experience should attempt such work.

NEVER assume everyone is as safety conscious as you are.

Personal Safety

NEVER allow minors and/or any unqualified personnel to operate or be near this equipment unless properly supervised.

NEVER allow anyone to ride on this equipment at any time.

NEVER leave this equipment running unattended.

NEVER wear loose or torn clothing while working around moving parts.

NEVER step on the PTO drive shaft at any time.

ALWAYS wear appropriate personal safety equipment and gear as called for by the job or working conditions.

ALWAYS be aware of pinch point areas on this equipment.

ALWAYS keep hands, feet, hair, and clothing away from moving parts.

ALWAYS stop and disengage the PTO and shut off the tractor before doing any adjusting or servicing to this equipment.

Towing Safety

THE MAXIMUM SPEED FOR TOWING THIS EQUIPMENT IS 20 MPH.

Observe the recommended maximum road speed limit, local speed limit, or maximum recommended towing speed whichever is the lesser speed.

ALWAYS MOVE THIS EQUIPMENT WITH A FARM TRACTOR ONLY.

Always engage power steering (on equipment with steering capabilities) before turning with a load.

DO NOT DISENGAGE power steering (on equipment with steering capabilities) before the turning process is completed.

Tractor must be heavy and powerful enough and have adequate braking power for the towed load.

STOPPING DISTANCE increases with speed and weight of towed loads and on slopes. Towed loads, with or without brakes, which are too heavy for the tractor or are towed too fast can cause loss of control. Consider the total weight of all equipment and the load.

Use additional caution when towing loads under adverse surface conditions (ice, mud, loose gravel, etc.), turning, or slopes.

Operation Safety

Before each tow check the electrical connection, tail lights, brake lights, and turn signals. Damaged lights or improper electrical connection between the tractor and this equipment will result in inoperable lights and/or inoperable electric brakes.

Do not operate on public roads after dark without warning lights.

Be sure the rear of this equipment has a visible and clean "Slow Moving Vehicle" emblem properly displayed. If towing at speeds less than 20 MPH on any public roadway at night, proper warning and running lights are necessary as required by state law!

DO NOT pull this equipment without having safety chains (not supplied) securing this equipment to the tractor.

Refer to local transportation laws for regulation on safety chain use. **MAXIMUM TOWING SPEED IS 20 MPH.**

The tractor must be of sufficient size to maintain vehicle stability when this equipment is fully loaded.

ALWAYS use a hitch pin which has a safety clip pin!

If this equipment includes a braking system, check oil level and braking capacity with a full load before operating or moving this equipment.

Check the wheel lug bolts and lug nuts daily and tighten as needed.

Replace any parts showing signs of excessive wear, cracking, or likelihood of failure with original equipment service parts.

Be familiar with all valves, doors, gates, and hydraulic controls.

BEFORE USE make sure this equipment does **NOT** have any foreign objects or materials which can cause equipment damage or personal injury.

NEVER ENTER THIS EQUIPMENT UNLESS ABSOLUTELY NECESSARY! If entry is necessary, take proper safety precautions to include but not limited to:

- Additional person on site and on the outside near the point of entry
- Safety harness and ropes where appropriate or required by law
- Proper life support system where appropriate or required by law
- Mechanical and electrical power disconnected
- Contacting your Balzer dealer for more information before entering

Check that the PTO slides freely, is not damaged, and is properly secured to the tractor and this equipment. Make sure there is approximately 1/3 overlap of engagement.

Be alert and avoid loose, soft, or icy surface conditions which could cause tipping or loss of control.

When possible, travel straight up or down a slope. Avoid traveling along side of hills, ditches, or other sloped surfaces.

Slow down prior to going down any steep grade.

Always check the job site for hazardous terrain, obstructions, or bystanders.

Never take tractor out of gear when going up or down a hill.

Do not exceed the maximum weight carrying capacity of the equipment or the tractor manufacturer's maximum towing capacity, whichever is the lesser weight. If you have any questions, contact your Balzer dealer.

Never use a tractor that is not recommended for this equipment's application.

When agitating a pit, always make sure there is adequate ventilation in any confined area.

Do not stand in front, behind, or along side this equipment when it is in operation or in motion.

When parking this equipment, securely block the wheels before unhitching from the tractor.

Hydraulic System Safety

DO NOT smoke when working on hydraulic systems.

NEVER use your hand to search for hydraulic fluid leaks. Escaping fluid under pressure can be invisible and can penetrate the skin causing serious injury and other health hazards. Escaping fluid can also be extremely hot causing severe burns.

Use a scrap piece of cardboard to check for leaks.

IF ANY FLUID IS INJECTED INTO YOUR SKIN, SEEK MEDICAL ATTENTION IMMEDIATELY! Notify medical staff that there is an injection injury with hydraulic fluid. Injected fluid must be surgically removed by a doctor familiar with this type of injury or gangrene may result.

DO NOT attempt to loosen or disconnect any lines, hoses, or fittings without first relieving hydraulic circuit pressure. Be careful not to touch any hydraulic components recently in operation because they can be extremely hot.

ALWAYS replace hydraulic components with manufacturer recommended replacement parts. Improperly rated components may result in system failure and/or injuries.

Contact your local Balzer dealer to order replacement parts.

Safety Signs and Decals

Safety signs or decals provide very important information and instructions designed to alert you to dangers and hazards which can be present during operation of this equipment. These safety signs and decals **MUST** be read, understood, and followed to be effective.

Replacement of Safety Signs and Decals

Safety signs and decals must be kept clean and readable. If they become unreadable for any reason, they must be replaced with an identical replacement sign or decal. Safety signs and decals must also be replaced if damaged when repairing this equipment or if not included with the replacement part.

Application of Safety Decals

Surface preparation is very important for the safety decals to properly adhere. Grease, oil, and dirt must be removed and the surface must be smooth and dry. After wiping the surface clean, use an ammonia-free window cleaner to provide the best surface for decal adherence.

Most decals have a split backing which is meant to be removed from the split outward. To apply decals, follow these steps:

1. Position the decal in the proper location and hold firmly over the largest portion of the backing.
2. Use one hand to hold the decal in position. With the other hand, carefully roll the loose end over and peel the backing outward. When the backing is removed as shown in Figure 1 and with even and gradual pulling, the decal will roll onto the surface smooth and wrinkle free,
3. With the smallest portion of the decal attached, the repeat Step 2 for the other half of the decal.

When the decal has been attached in place, use a cloth or soft paper towel to burnish the decal onto the cleaned surface. Work gently from the middle outwards to avoid creating any wrinkles and to remove any air bubbles.

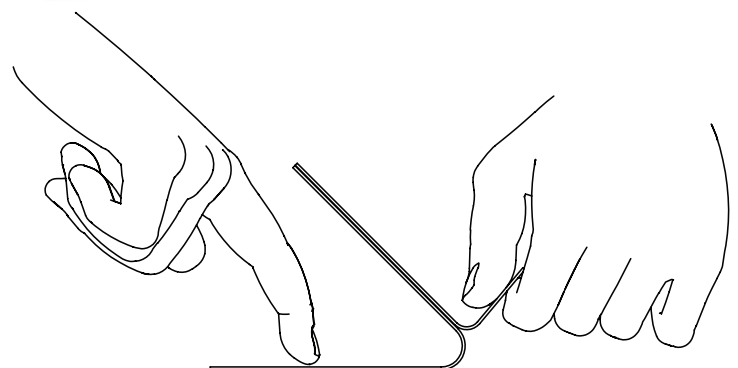
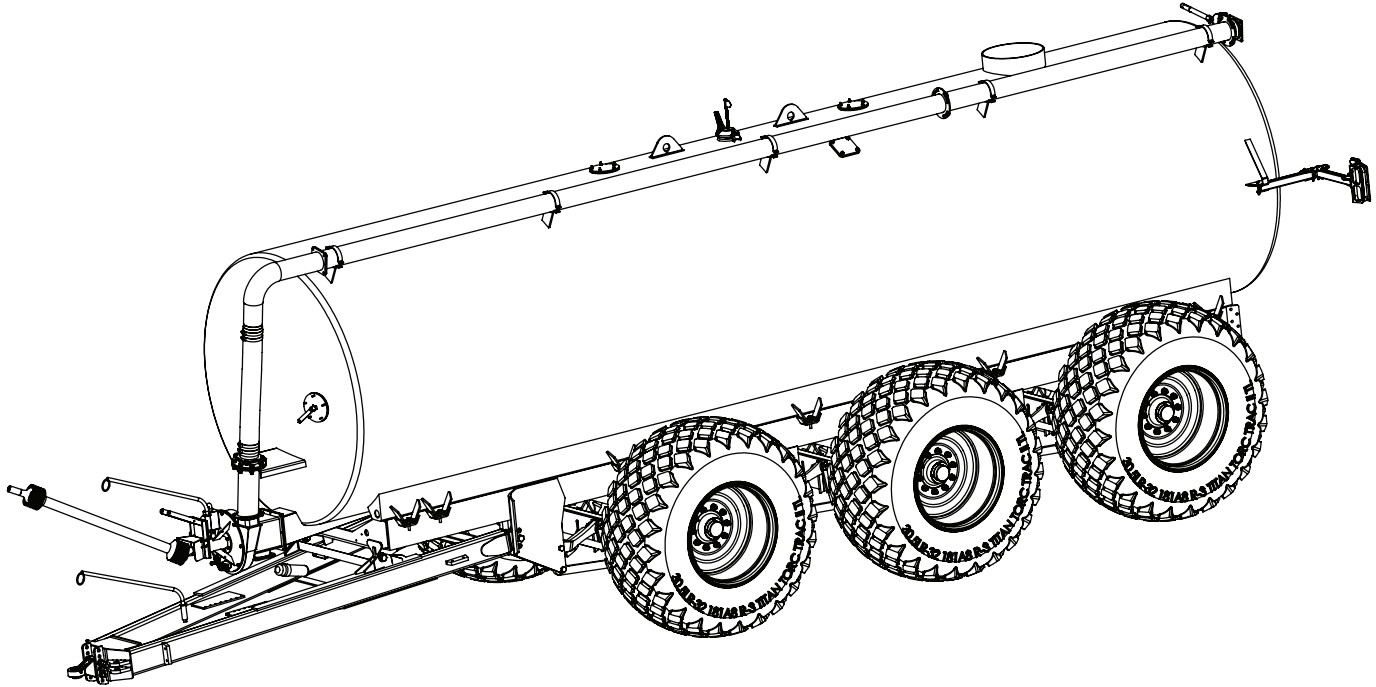

Figure 1

The logo for BALZER, featuring the word in a bold, italicized, sans-serif font with a white outline and a grey drop shadow. The logo is positioned on a green diagonal band that runs from the top left towards the bottom right.

BALZER

Technical Data



Dimensions

See "Dimensions" on page 13

Tire Pressure

28L X 26 R3	26 PSI (180 kPa)
28LR26 R3	54 PSI (372 kPa)
30.5 X 32 R1	33 PSI (228 kPa)
30.5 X 32 R3	33 PSI (228 kPa)
30.5LR32 R1	52 PSI (359 kPa)
30.5LR32 R3	52 PSI (359 kPa)
850/50 30.5	37 PSI (256 kPa)
900/60 R1	35 PSI (242 kPa)

Lug Nuts

Torque to 450 FT/LBS

Brake Type

Disc

Hydraulic Operating Pressure

Up to 3000 PSI
(20.68 MPa)

Electrical System

12 VDC

Electrical Connection

7-Way Receptacle

Maximum Tow Speed

20 MPH
(32 KPH)

PTO Speed

1000 RPM

Dimensions

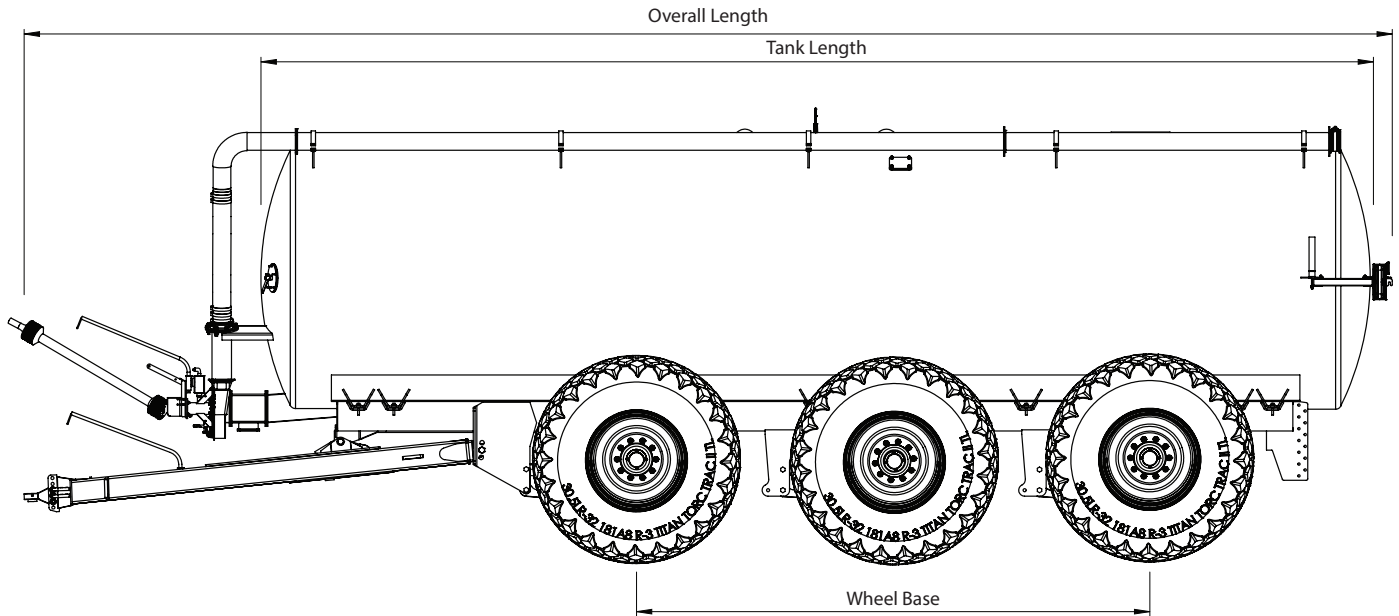

Specification	Magnum Slurry Tank		
	7500	8500	9500
Overall Length	465" (1181 cm)	465" (1181 cm)	465" (1181 cm)
Overall Width	152 3/8" (387.0 cm)	152 3/8" (387.0 cm)	152 3/8" (387.0 cm)
Overall Height	145" (368.3 cm)	150" (381.0 cm)	155" (393.7 cm)
Tank Length	342" (868.7 cm)	342" (868.7 cm)	342" (868.7 cm)
Tank Diameter	79" (200.7 cm)	84" (213.4 cm)	89" (226.1 cm)
Wheel Base	172" (436.8 cm)	172" (436.8 cm)	172" (436.8 cm)
Clearance	19" (48.25 cm)	19" (48.25 cm)	19" (48.25 cm)
Capacity	7500 Gallons (28,390 Liters)	8500 Gallons (32,175 Liters)	9500 Gallons (35,960 Liters)
Empty Weight	~23,000 lbs (~10,430 kgs)	~24,000 lbs (~10,885 kgs)	~24,500 lbs (11,115 kgs)

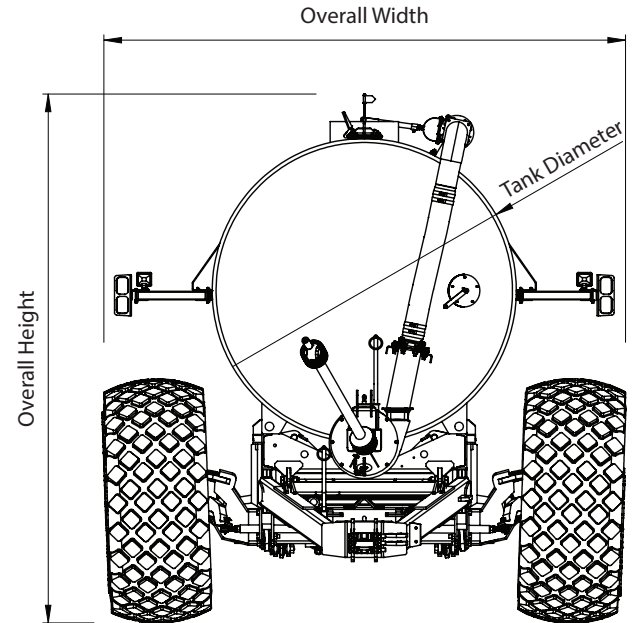

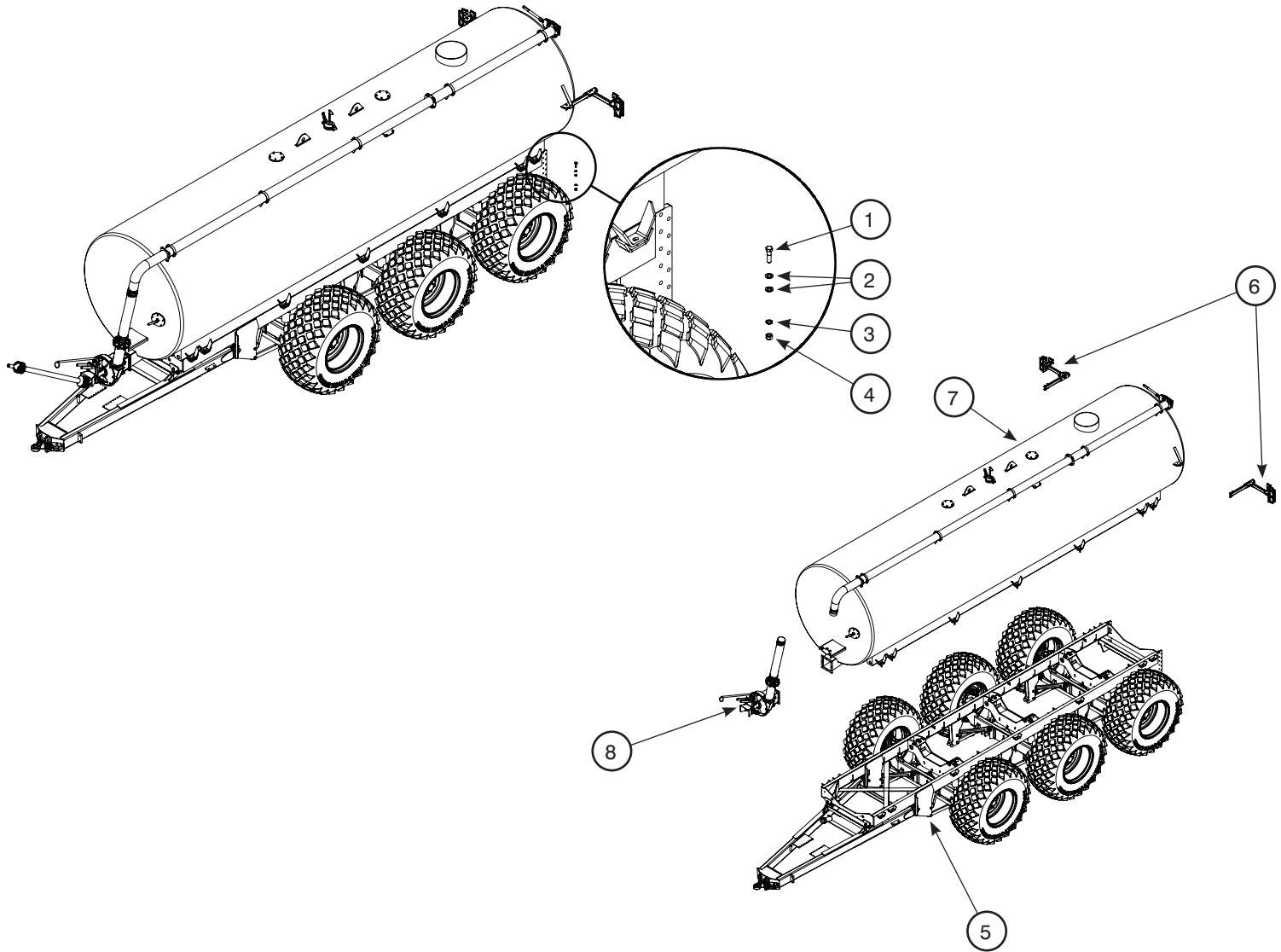

Item	Description	Quantity	Part Number
1	Bolt, Hex Head, 3/4"-10 X 2 3/4" GR5	14	1314
2	Flat Washer, 3/4"	28	1603
3	Lock Washer, 3/4"	14	1641
4	Nut, 3/4" GR5	14	1727

Item	Description	Reference
5	Frame	Page 13
6	Electrical/Lights	Page 41
7	Slurry Tank	Page 47
8	Slurry Pump	Page 53

BALZER

Frame

Tridem Frame

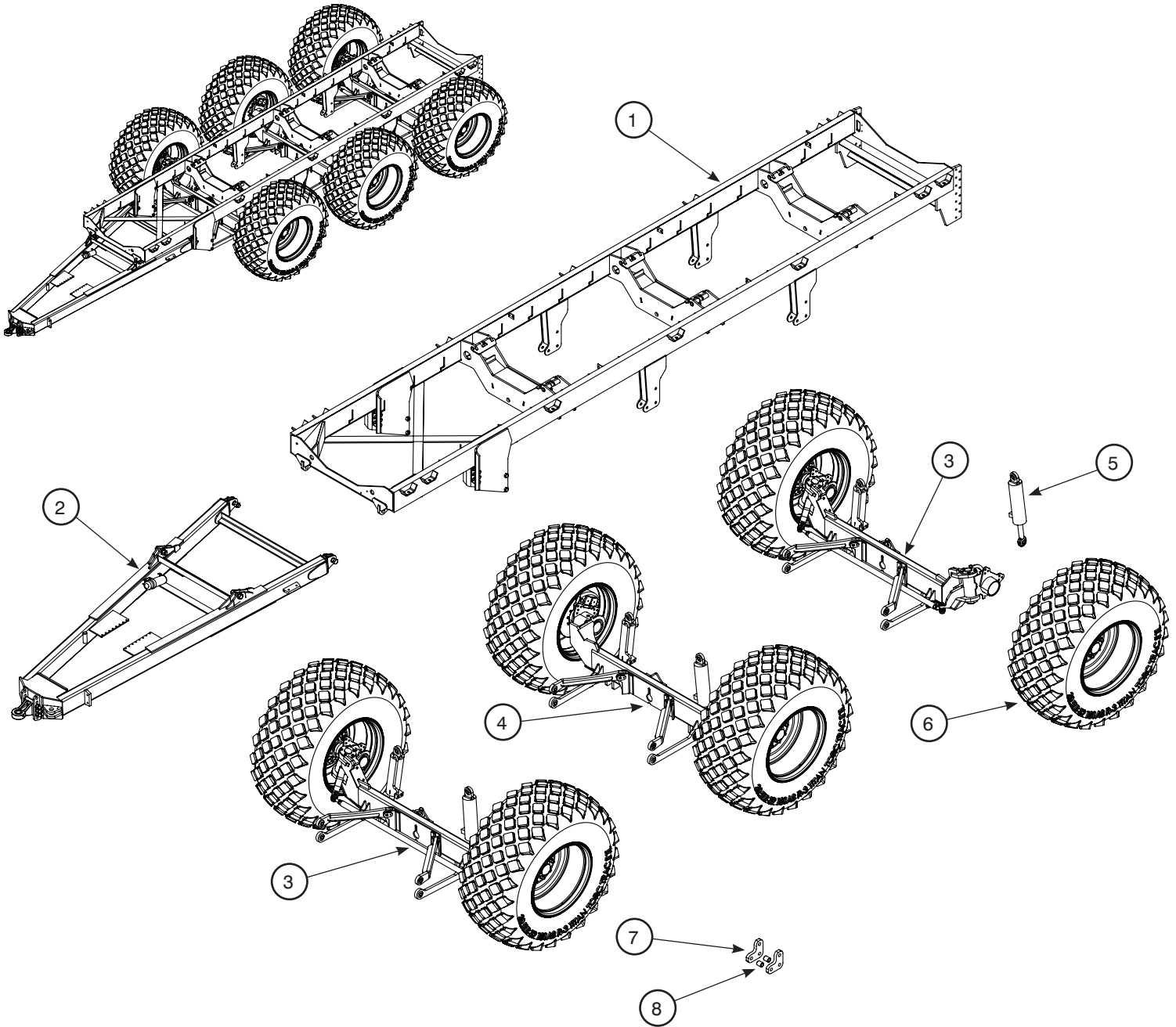

Item	Description	Quantity
1	Frame Assembly	1
2	Tongue Assembly	1
3	Steering Axle Assembly	2
4	Straight Axle Assembly	1
5	Suspension System, Hydraulic Cylinder	6
6	Tires, 10 Bolt, 13 3/16" Bolt Circle	6
7	Suspension Adapter Plate (900/60 32 R1 Tires Only)	12
8	Suspension Adapter Bushing (900/60 32 R1 Tires Only)	12

Tridem Frame Assembly

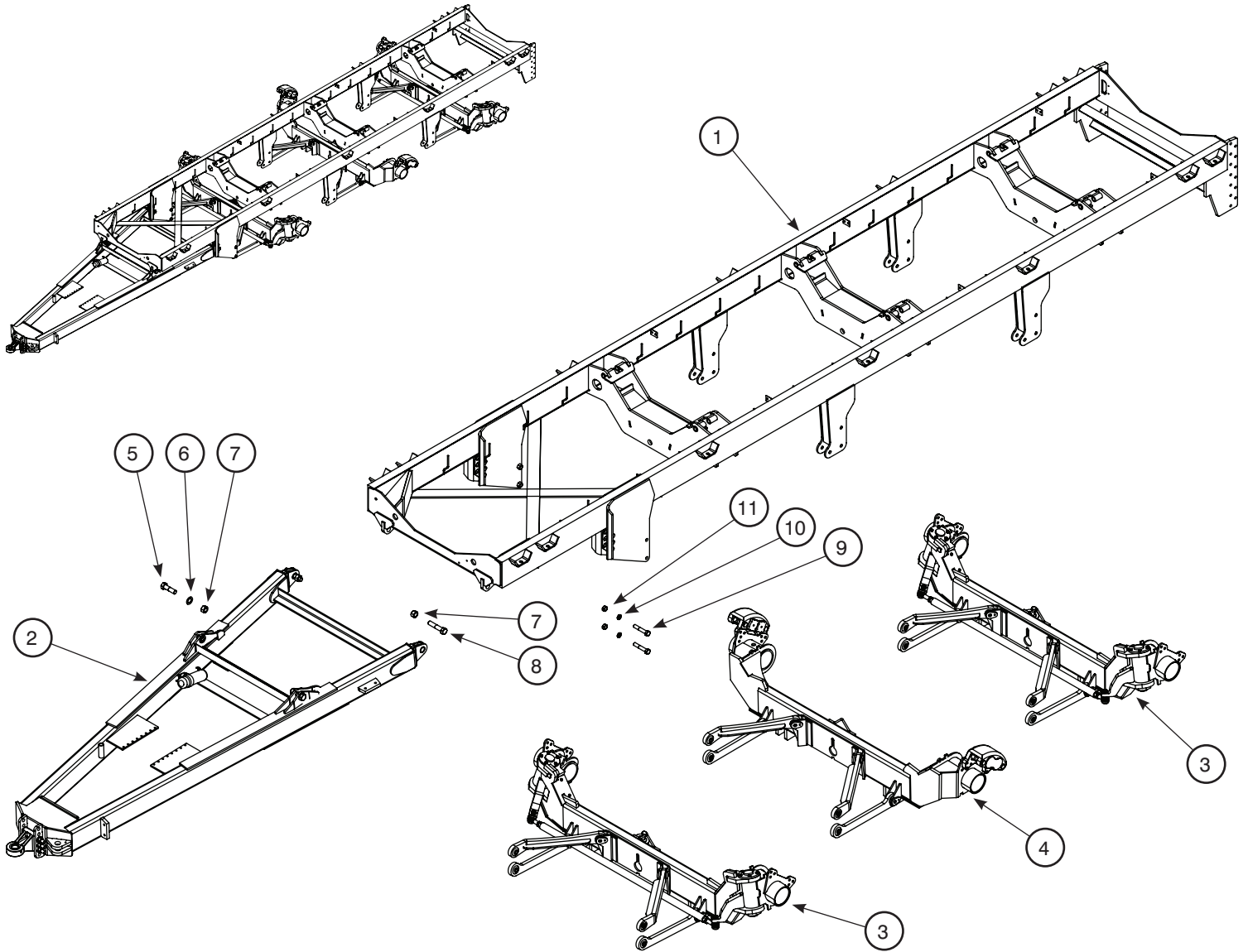

Item	Description	Quantity	Part Number
1	Tandem Tank Frame	1	122021
2	Tongue Assembly	1	
3	Steering Axle Assembly	2	
4	Straight Axle Assembly	1	
5	Bolt, Hex Head, 1 1/4"-7 X 4 1/2" GR8	2	2563
6	Flat Washer, 1 1/4"	2	125045
7	Nut, Top Lock, 1 1/4"-7	4	1780
8	Bolt, Hex Head, 1 1/4"-7 X 6" GR8	2	808003
9	Bolt, Hex Head, 1"-8 X 5 1/2" GR8	12	1348
10	Lock Washer, 1"	12	1643
11	Hex Nut, 1"-8	12	1699

Tongue Assembly

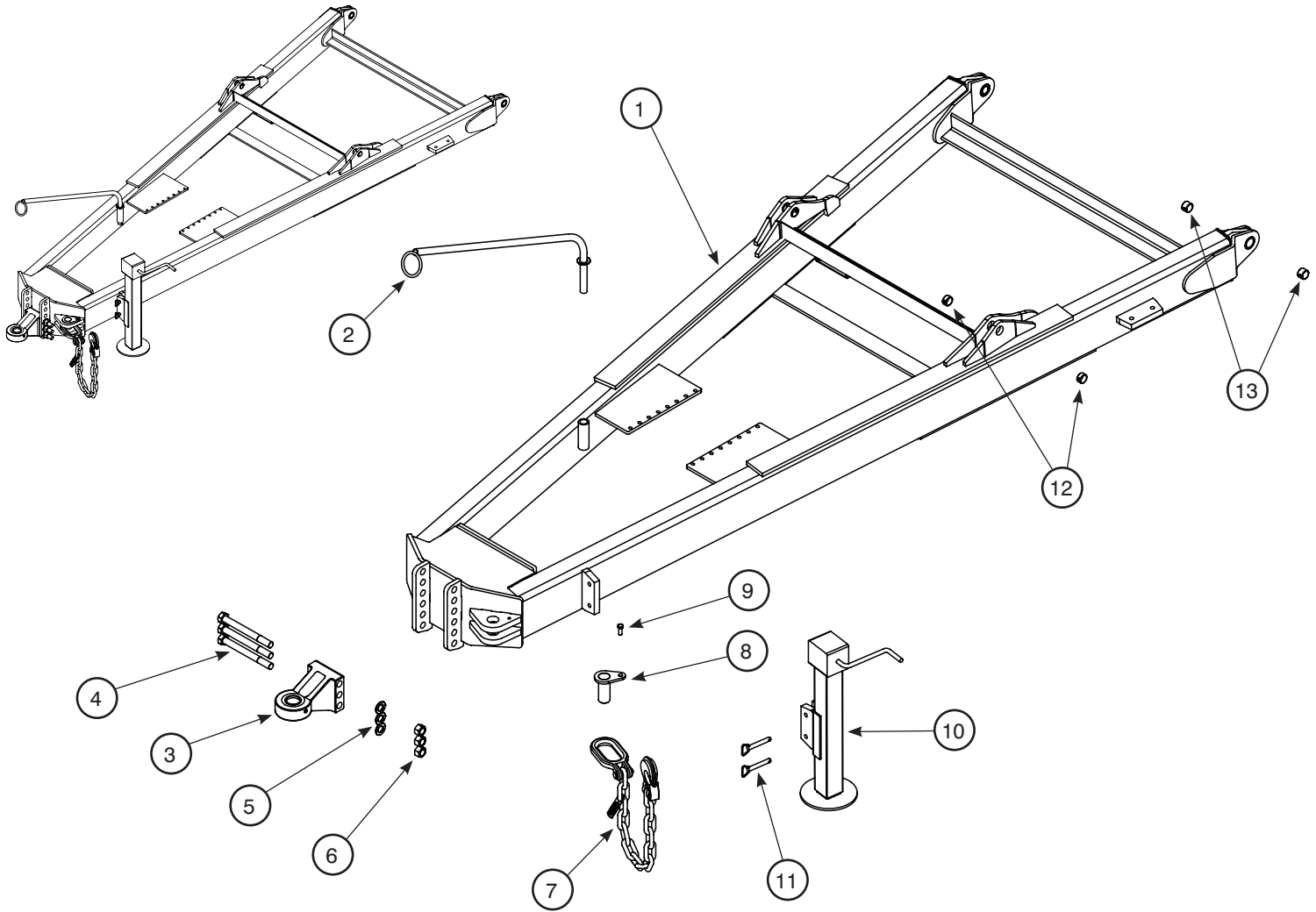

Item	Description	Quantity	Part Number
1	Tongue Frame Weldment	1	122816
2	Hose Hanger (For Optional Hydraulic Motor)	1	83078
3	Hitch, Bull Pull, 3-Bolt	1	85945
4	Bolt, Hex Head, 1"-8 X 10" GR8	3	85936
5	Lock Washer, 1"	3	1643
6	Nut, Top Lock, 1"-8	3	1779
7	Safety Chain, Agricultural, 80,000 lbs (ASAE S338.5)	1	96169
8	Pin, Safety Chain	1	902500
9	Bolt, Hex Head, 3/8"-16 X 1 1/4" GR5	1	1207
10	Jack Crank w/Bracket	1	83338
11	Ball Lock Pin with Chain, 5/8" X 3"	2	90646
12	Spring Bushing, 1 1/2" OD X 1 1/4" ID X 3/4"	4	60786
13	Spring Bushing, 1 1/2" OD X 1 1/4" ID X 1"	4	27728

Bull Pull Hitch Inserts

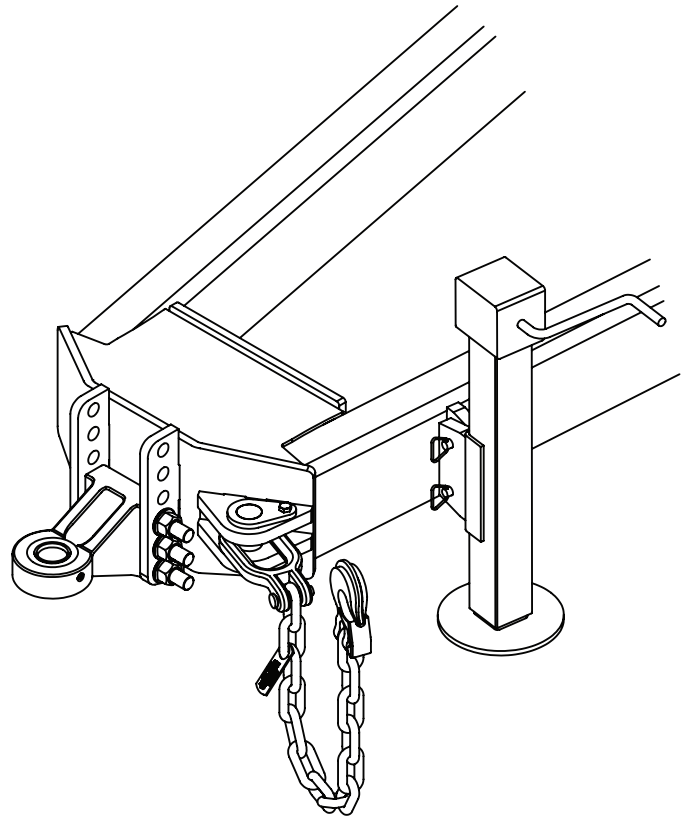
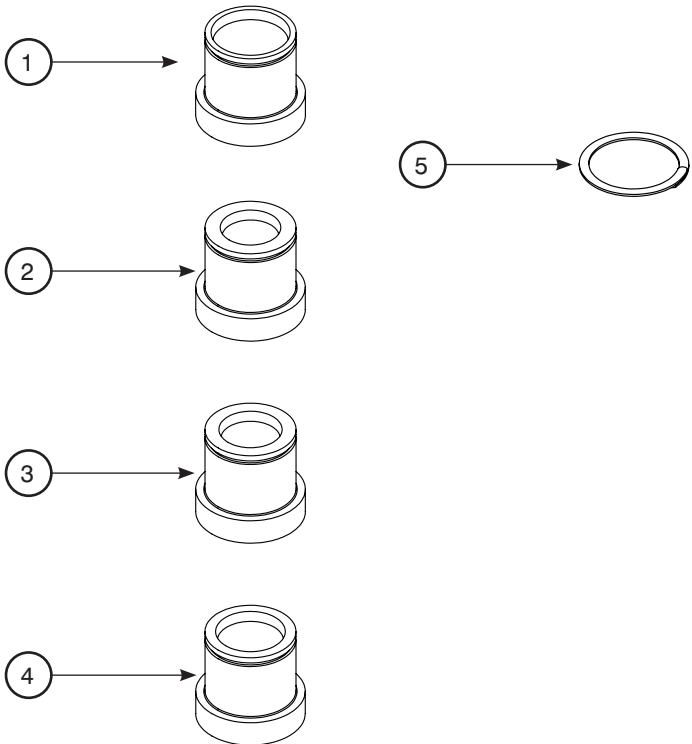

Item	Description	Quantity	Part Number
1	Bull Pull Insert, 2" (Standard)	1	85947
2	Bull Pull Insert, 1 1/2" (Optional)	1	85948
3	Bull Pull Insert, 40mm (Optional)	1	85949
4	Bull Pull Insert, 1 3/4" (Optional)	1	85974
5	Spiral Retaining Ring, Bull Pull Insert	1	85978

BALZER

Suspension

Tridem Suspension Hydraulics

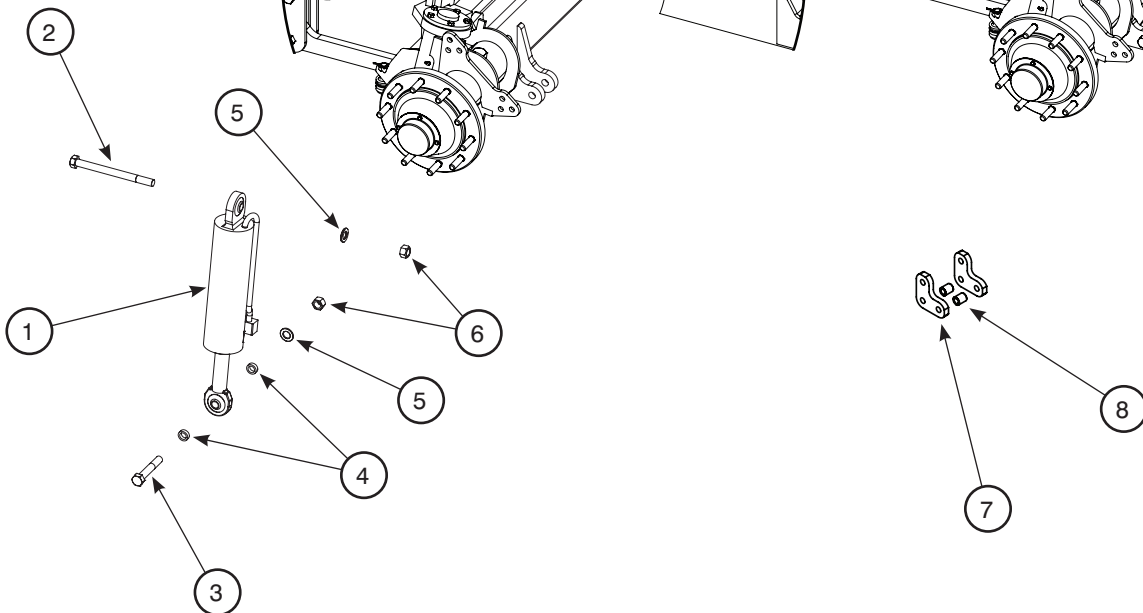
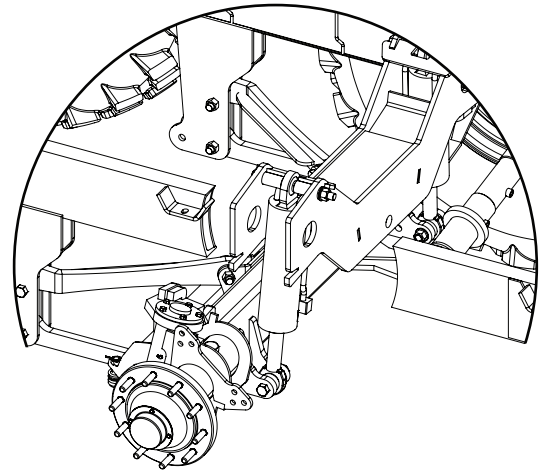
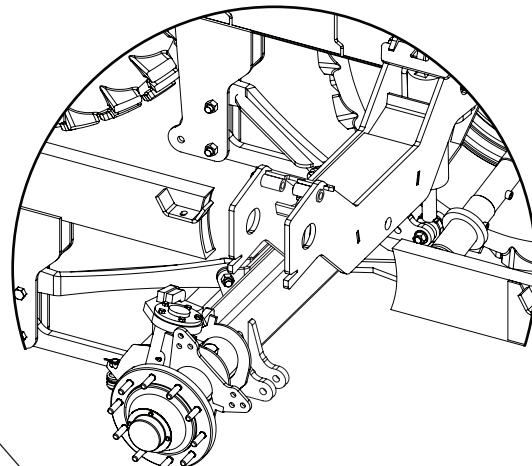
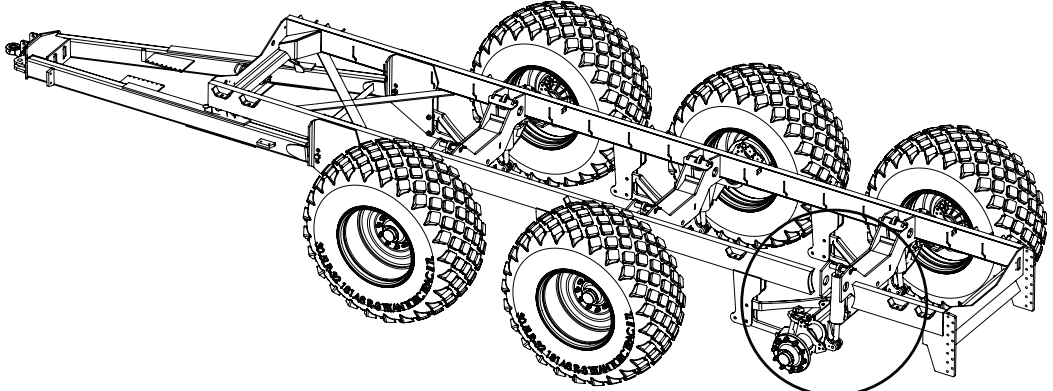

Item	Description	Quantity	Part Number
1	Hydraulic Suspension Cylinder	6	900335
2	Bolt, Hex Head, 1"-8 X 12" GR8	6	1358
3	Bolt, Hex Head, 1"-8 X 8" GR8	6	1349
4	Spacer, 1 1/2" OD X 1/2" Long	12	83329
5	Lock Washer, 1"	12	1643
6	Nut, 1"-8	12	1699
7	Suspension Adapter Plate (900/60 32 R1 Tires Only)	12	214007
8	Suspension Adapter Bushing (900/60 32 R1 Tires Only)	12	900420

Tridem Suspension Hydraulic Ports

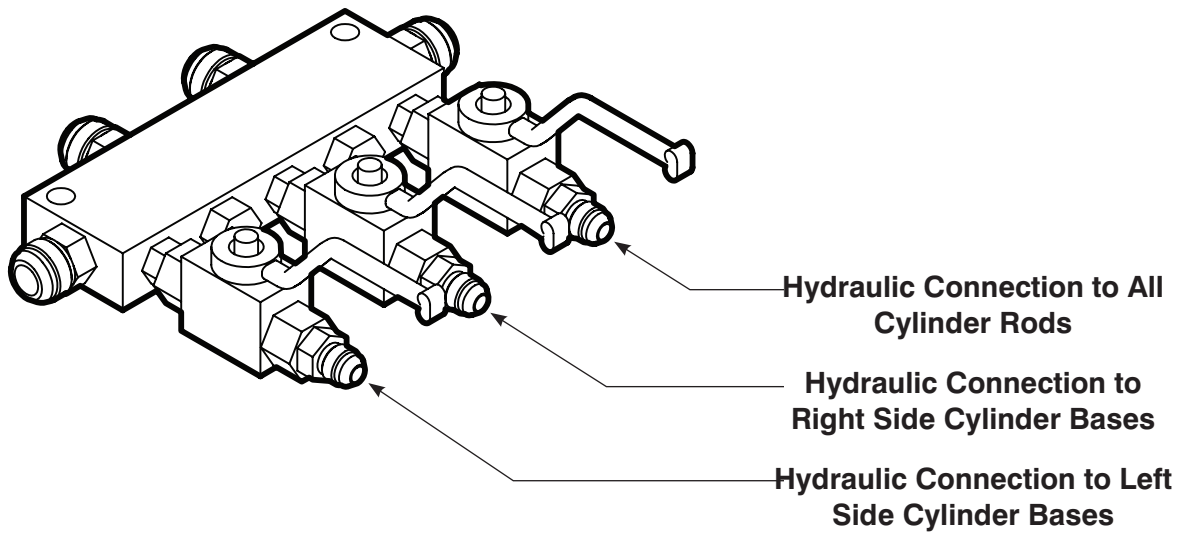
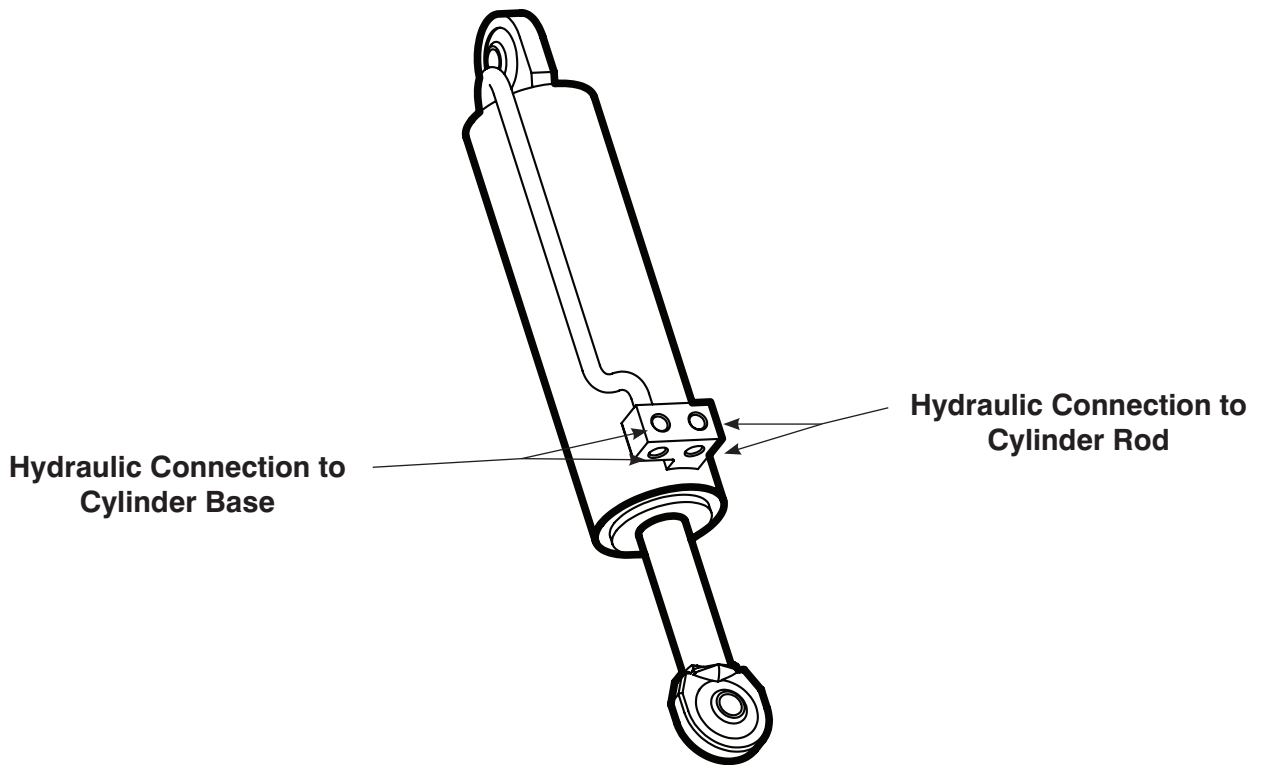

Tridem Suspension Hydraulic Fittings

Left Front Cylinder Assembly

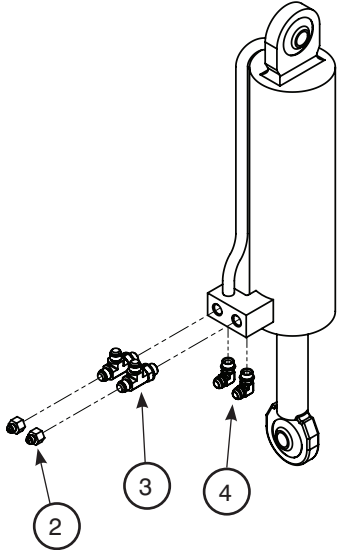

Right Front Cylinder Assembly

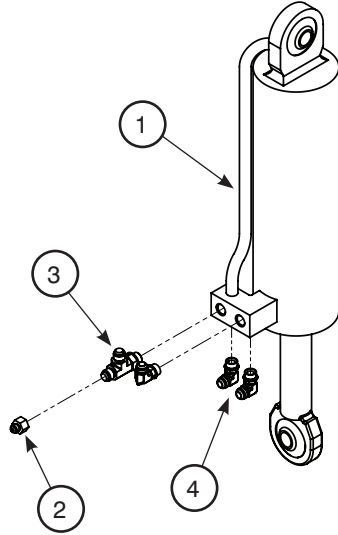

Middle Cylinder Assemblies

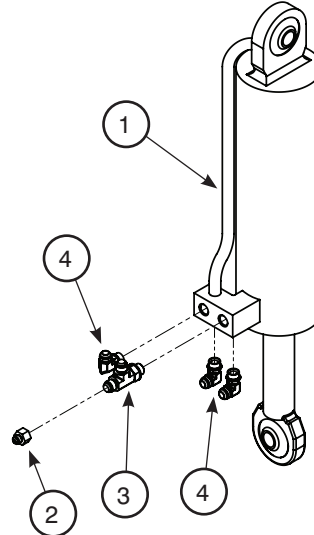

Rear Cylinder Assemblies

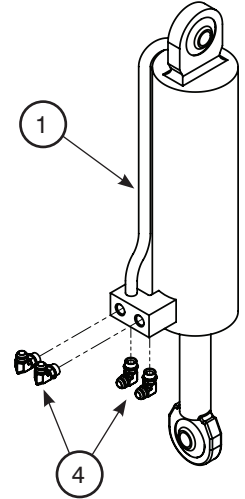

Hydraulic Suspension Manifold

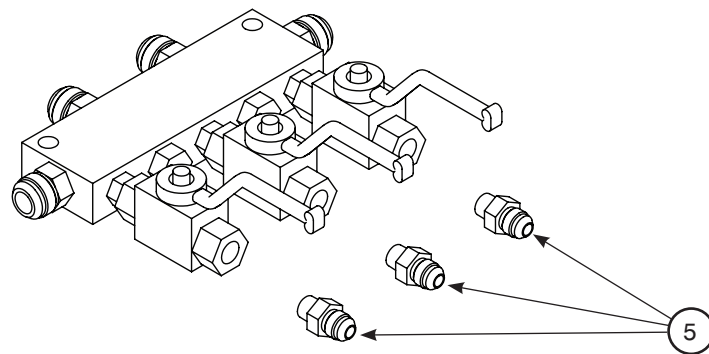

Item	Description	Quantity	Part Number
1	Hydraulic Suspension Cylinder, 5" X14", BAL-SOC, 5,000 PSI	6	900335
2	Hydraulic Reducer, 3/4" JICFM X 9/16" JICM	5	847004
3	Hydraulic Tee, 3/4" JICM X 3/4" ORM X 3/4" JICM	5	849001
4	Hydraulic Elbow, 3/4" JICM X 3/4" ORM, 90°	19	72831
5	Hydraulic Nipple, 9/16" JICM X 1/4" NPTM	3	33842

Tridem Suspension Hydraulic Connections

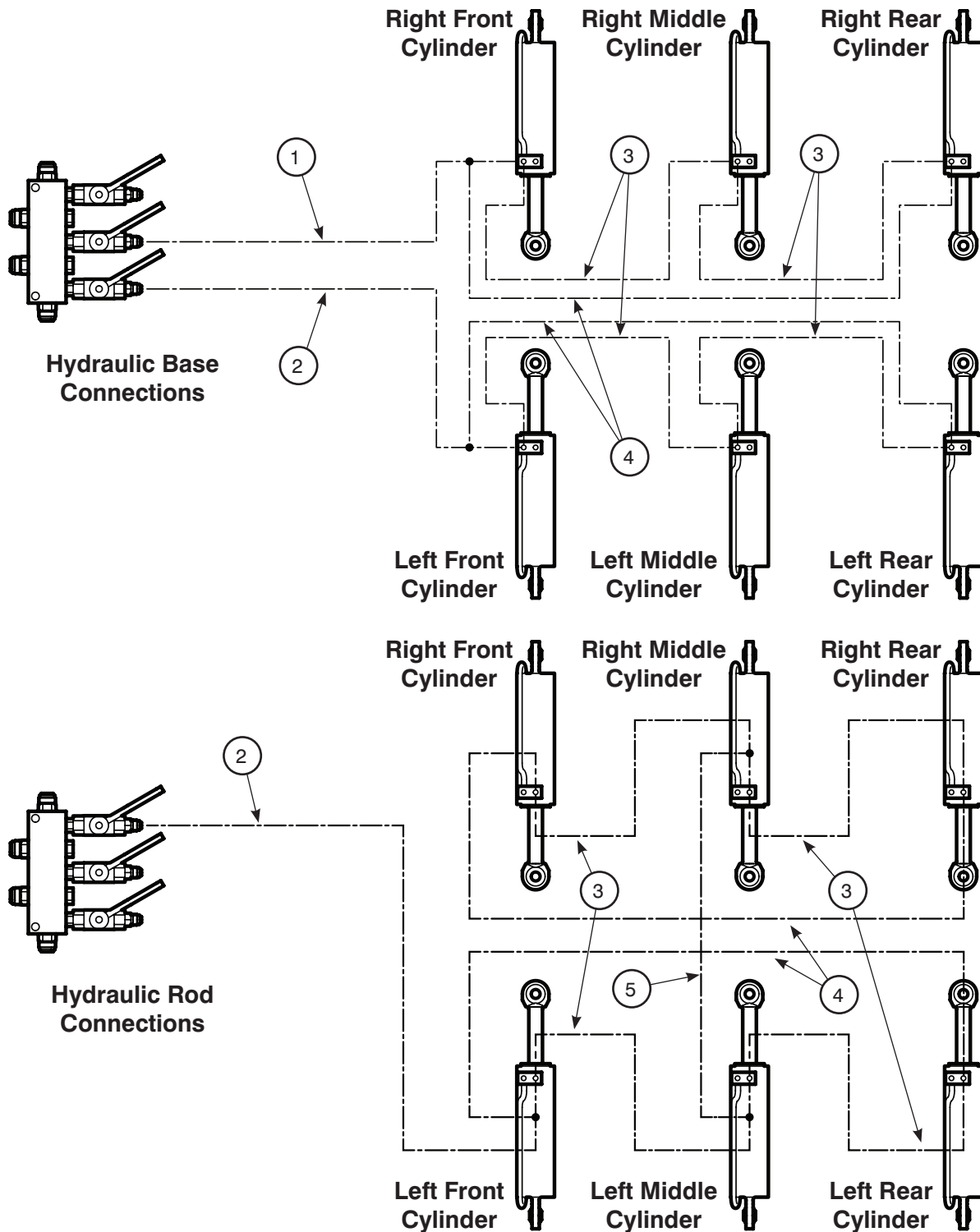

Item	Description	Quantity	Part Number
1	Hydraulic Hose, 1/4" X 9/16" JICFMS X 9/16" JICFMS 90° X 108" Long	1	852108
2	Hydraulic Hose, 1/4" X 9/16" JICFMS X 9/16" JICFMS 90° X 132" Long	2	852132
3	Hydraulic Hose, 1/2" X 3/4" JICFMS X 3/4" JICFMS 90° X 132" Long	8	855132
4	Hydraulic Hose, 1/2" X 3/4" JICFMS X 3/4" JICFMS 90° X 216" Long	4	855216
5	Hydraulic Hose, 1/4" X 9/16" JICFMS X 9/16" JICFMS 90° X 48" Long	1	852048

BALZER

Steering

Straight Axle Assembly

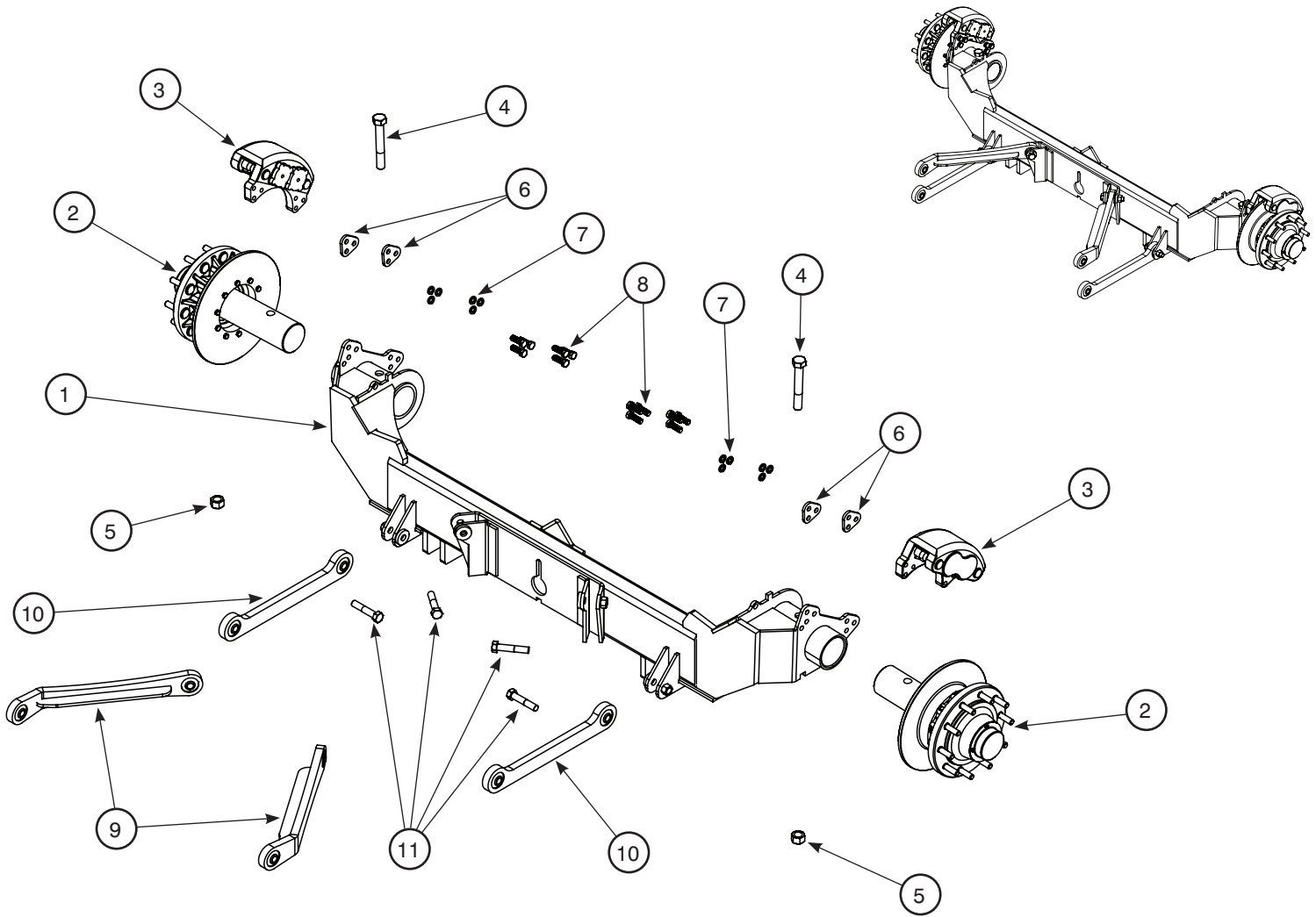

Item	Description	5" Ultra - 13 3/16" Bolt Circle		6" Ultra - 13 3/16" Bolt Circle	
		Quantity	Part Number	Quantity	Part Number
1	Straight Axle Weldment, 60	1	902509	1	902511
2	Wheel Hub and Spindle Assembly with Rotor	2	900126	2	900124
3	Brake Caliper	2	91853	2	91853
4	Bolt, Hex Head, 1 1/4"-7 X 8 1/2" GR8	2	33870	2	33870
5	Lock Nut, Nylon Insert, 1 1/4"-7	2	819000	2	819000
6	Brake Caliper Spacer, 1/8" (10 ga.) *	4 to 8	950015	4 to 8	950015
	Brake Caliper Spacer, 3/8" *	4	950016	4	950016
	Brake Caliper Spacer, 1/2" *	4	950017	4	950017
7	Split Lock Washer, 3/4"	12	1641	12	1641
8	Bolt, Hex Head, 3/4"-16 X 2 1/4"	12	1312	12	1312
9	Axle Drag Bar Assembly, Upper	2	900052	2	900052
10	Axle Drag Bar Assembly, Lower	2	900098	2	900098
11	Bolt, Hex Head, 1"-8 X 5" GR8	4	1347	4	1347

* May not be used with every assembly

STEERING

Steering Axle Assembly

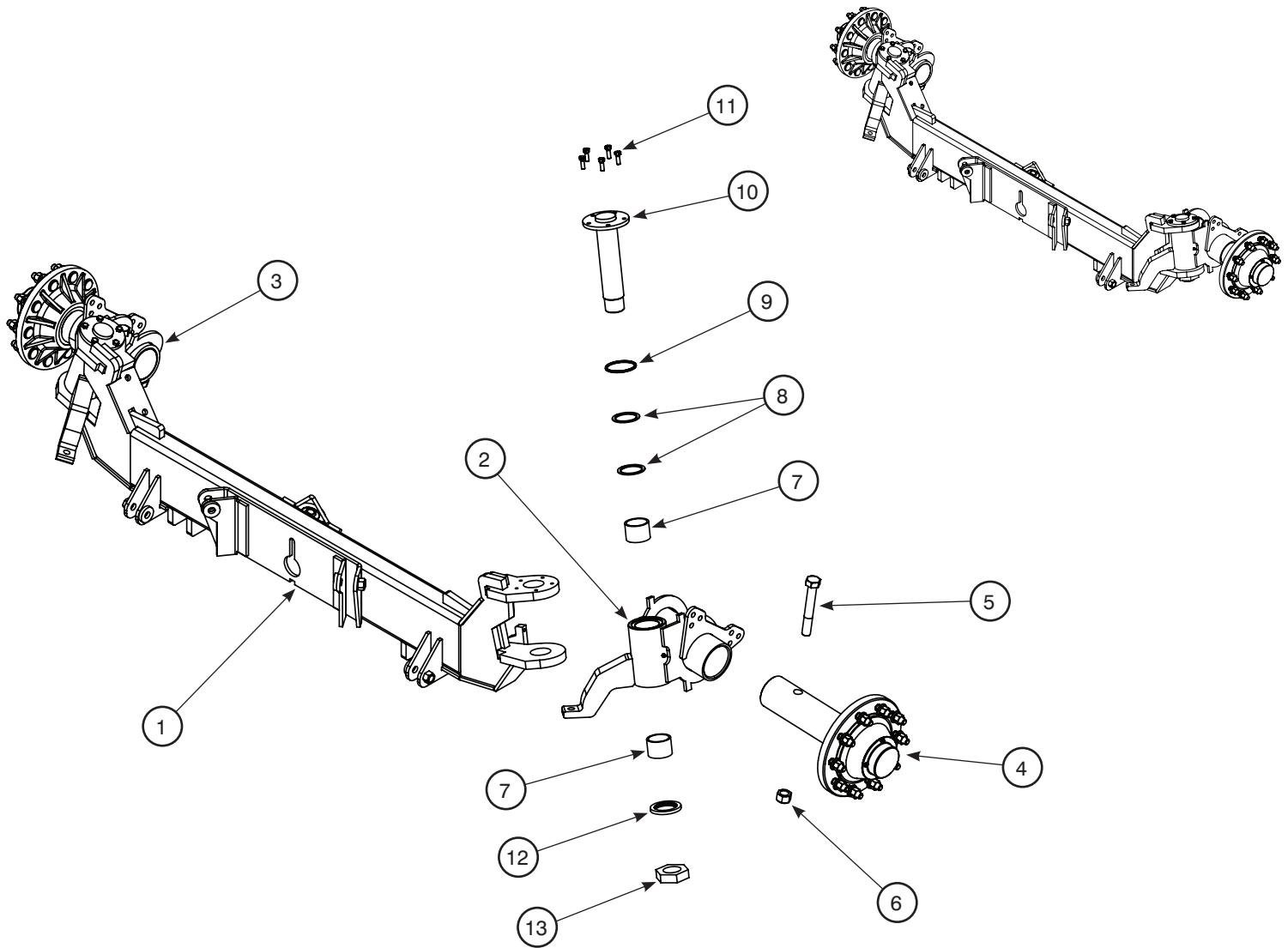

Item	Description	5' Ultra - 13 3/16" Bolt Circle		6' Ultra - 13 3/16" Bolt Circle	
		Quantity	Part Number	Quantity	Part Number
1	Steering Axle Weldment, 60	1	902510	1	902510
2	Steering Knuckle Assembly, Left	1	900065	1	900067
3	Steering Knuckle Assembly, Right	1	900066	1	900068
4	Wheel Hub and Spindle Assembly	2	900282	2	900124
5	Bolt, Hex Head, 1 1/4"-7 X 8 1/2" GR8	2	33870	2	33870
6	Lock Nut, Nylon Insert, 1 1/4"-7	2	819000	2	819000
7	Bushing, Polygon	4	865045	4	865045
8	Thrust Washer	4	70123	4	70123
9	X-ring, 4.10" ID X 0.21" CS (-346)	2	900116	2	900116
10	Bolt, King Pin	2	900082	2	900082
11	Bolt, Hex Head, 1/2"-13 X 1 1/2" GR5	10	1250	10	1250
12	Seal, 3" x 4 1/2" x 7/16" - Bun a-N	2	900117	2	900117
13	Nut, Jamb, 2 3/4"-12 UNF	2	900085	2	900085

Steering Axle Assembly

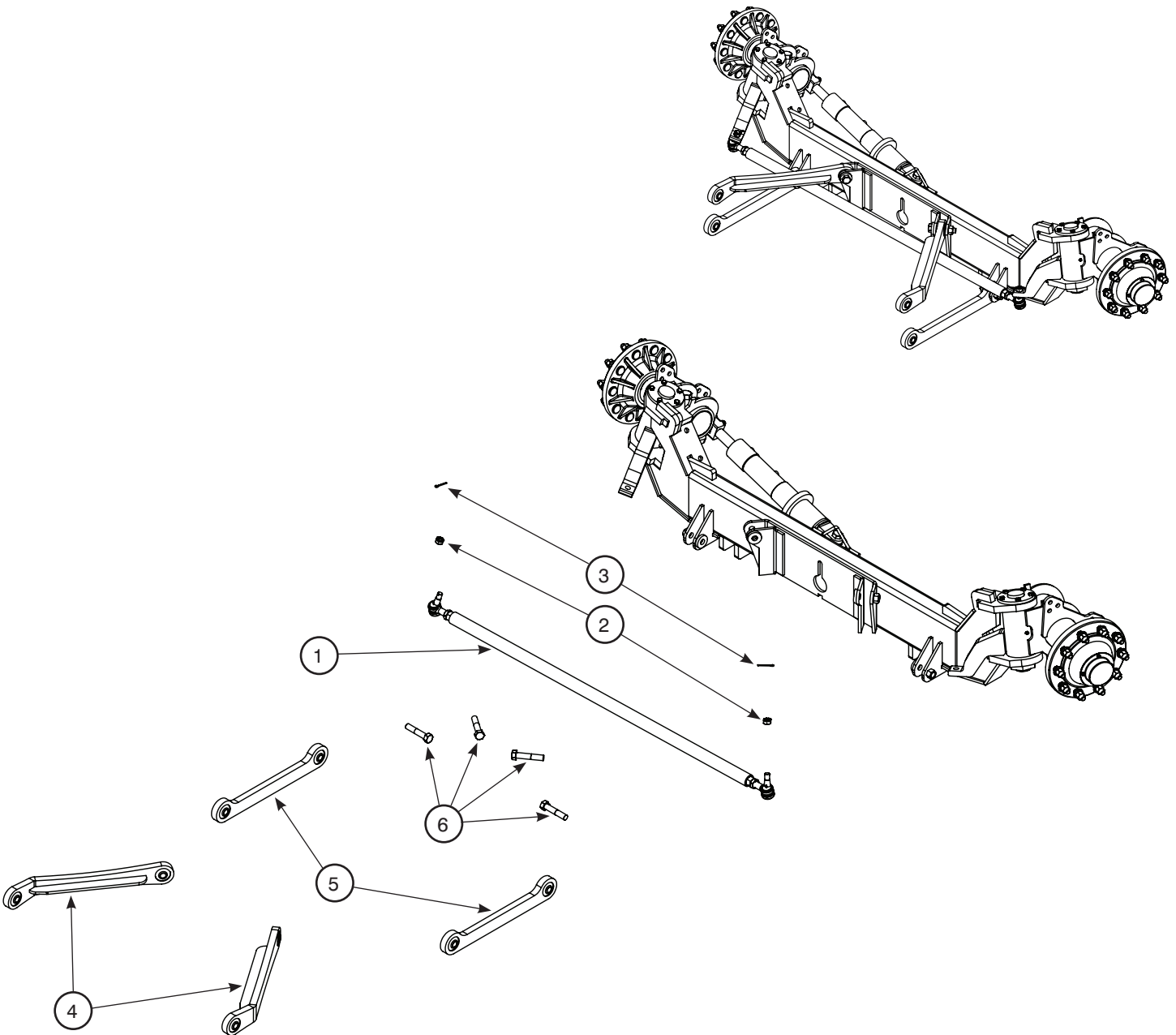

Item	Description	Quantity *	Part Number
1	Tie Rod Assembly	1	900061
2	Nut, Castle, 7/8" -14	2	1753
3	Cotter Pin, 3/16" x 2 1/4"	2	2056
4	Axle Drag Bar Assembly, Upper	2	900052
5	Axle Drag Bar Assembly, Lower	2	900098
6	Bolt, Hex Head, 1"-8 X 5" GR8	4	1347

* Quantity is for each steering axle.

STEERING

Steering Axle Assembly

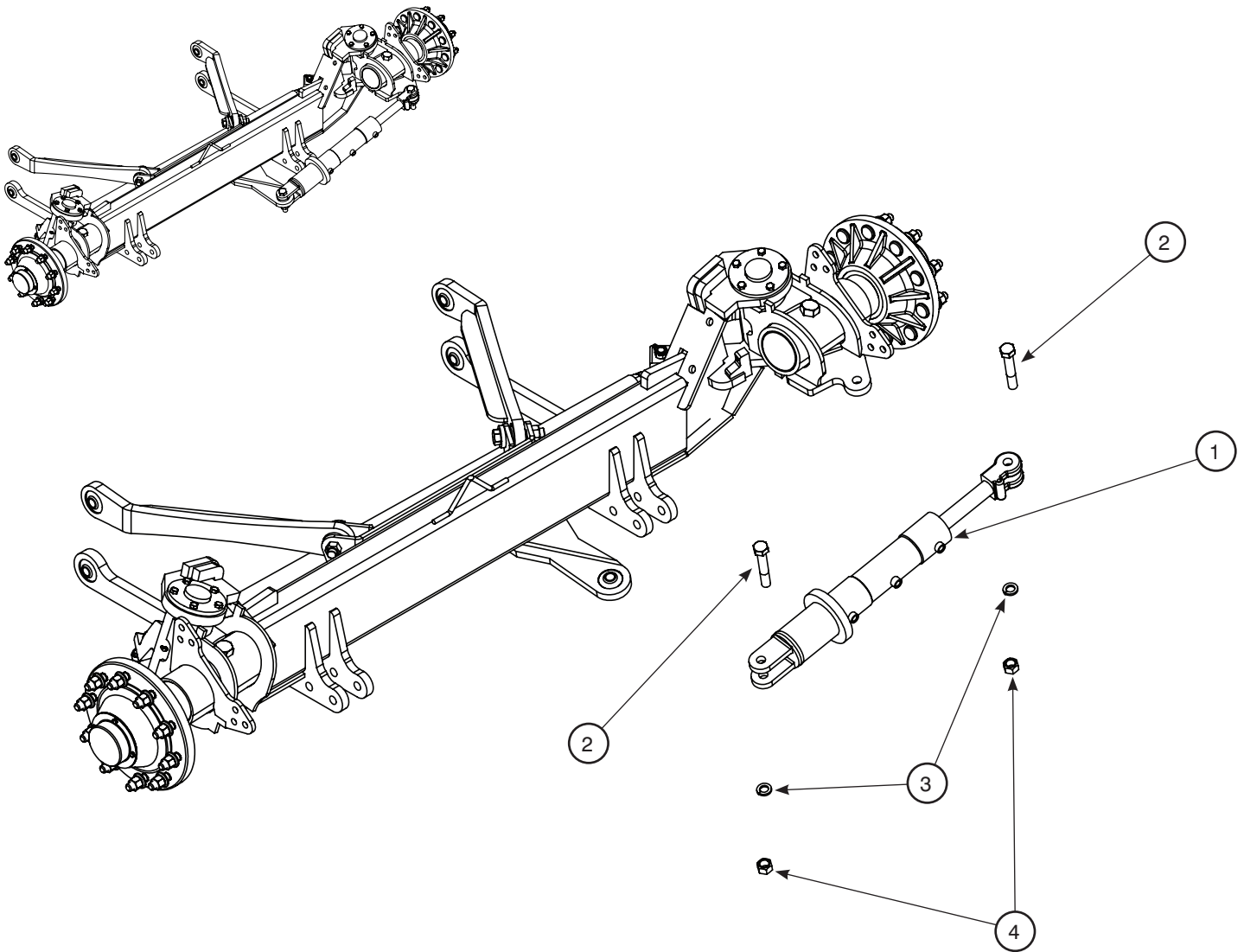

Item	Description	Quantity *	Part Number
1	Hydraulic Steering Cylinder	1	85300
2	Bolt, Hex Head, 1"-8 X 6" GR8	2	1349
3	Split Lock Washer, 1"	2	1643
4	Nut, 1"-8	2	1699

* Quantity is for each steering axle.

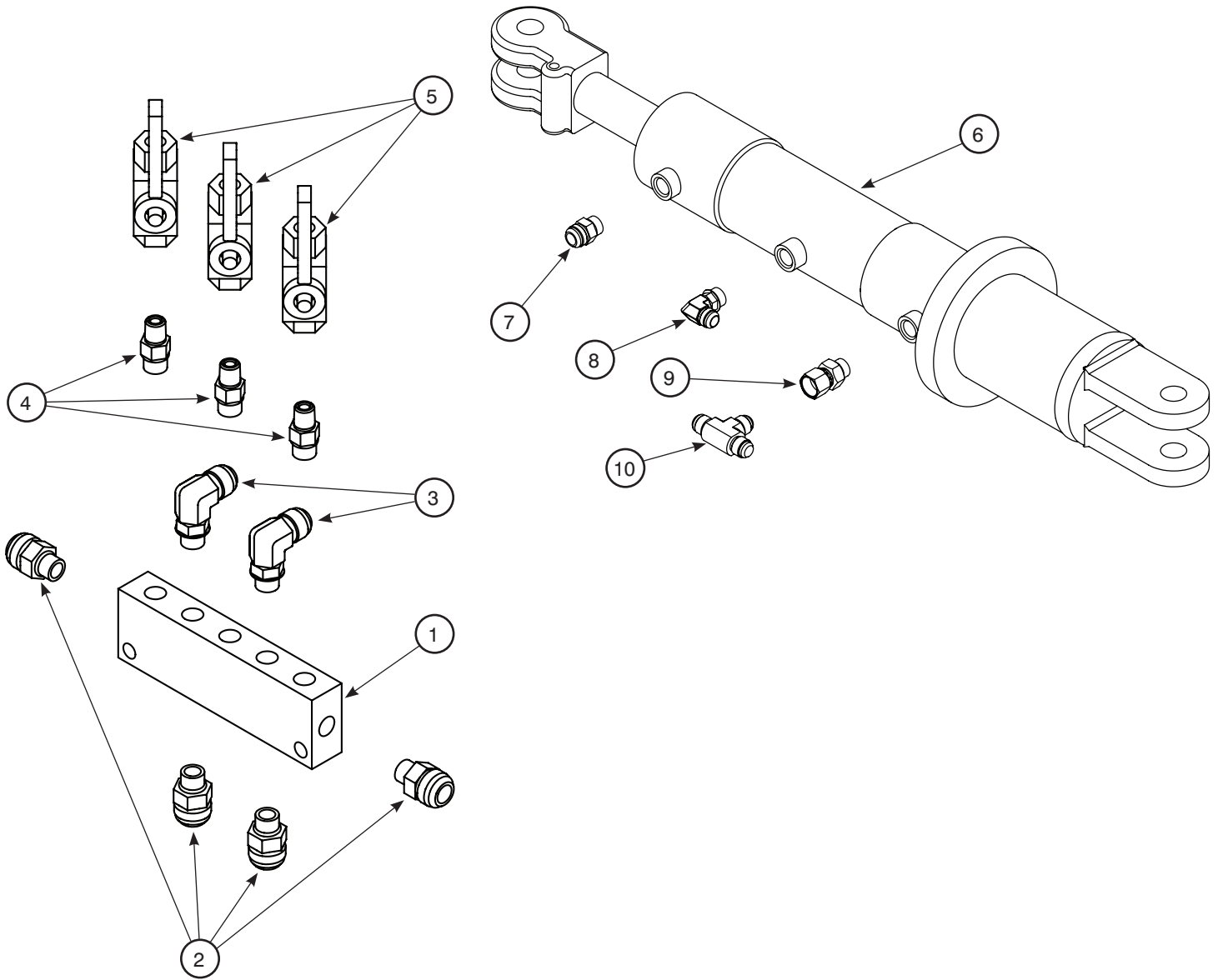

Item	Description	Quantity	Part Number
1	Hydraulic Manifold, Suspension Block	1	840000
2	Hydraulic Nipple, 3/4" JIC X 9/16" ORM	4	72581
3	Hydraulic Elbow, 3/4" JICM X 9/16" ORM, 90°	2	72591
4	Hydraulic Nipple, 9/16" ORM X 1/4" NPTM	3	33839
5	Hydraulic Ball Valve, 1/4" NPTFM X 1/4" NPTFM, 3000 PSI	3	71105
6	Cylinder, Hydraulic Steering	2	85300
7	Hydraulic Nipple, 3/4" JICM x 3/4" ORM	1 *	847001
8	Hydraulic Elbow, 3/4" JICM X 3/4" ORM, 90°	1 *	72831
9	Hydraulic Coupler, 3/4" ORM X 3/4" JICFMS	1 *	839001
10	Hydraulic Tee, 3/4" JICM X 3/4" JICM X 3/4" JICM	1 *	849000

* Quantity is for each steering hydraulic cylinder.

STEERING

Steering Hydraulics

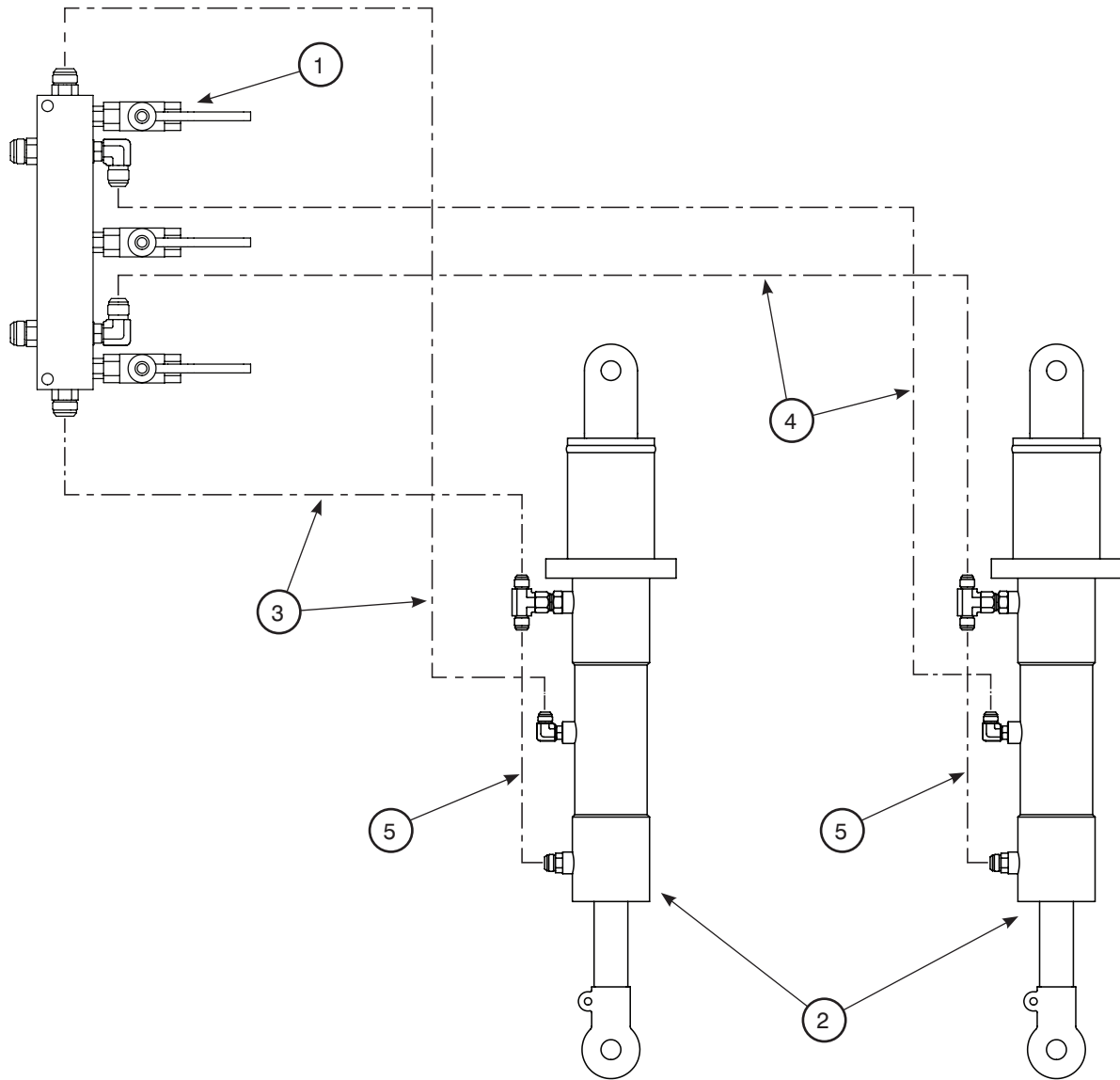

Item	Description	Quantity	Part Number
1	Hydraulic Suspension Manifold Assembly	1	
2	Hydraulic Steering Cylinder Assembly	2	
3	Hydraulic Hose, 1/2" X 3/4" JICFMS X 3/4" JICFMS, 90°, 132" LONG	2	855132
4	Hydraulic Hose, 1/2" X 3/4" JICFMS X 3/4" JICFMS, 90°, 312" LONG	2	855312
5	Hydraulic Hose, 1/2" X 3/4" JICFMS X 3/4" JICFMS, 90°, 14" LONG	2	855014

BALZER

Wheels

Spindle and Wheel Hub Assembly

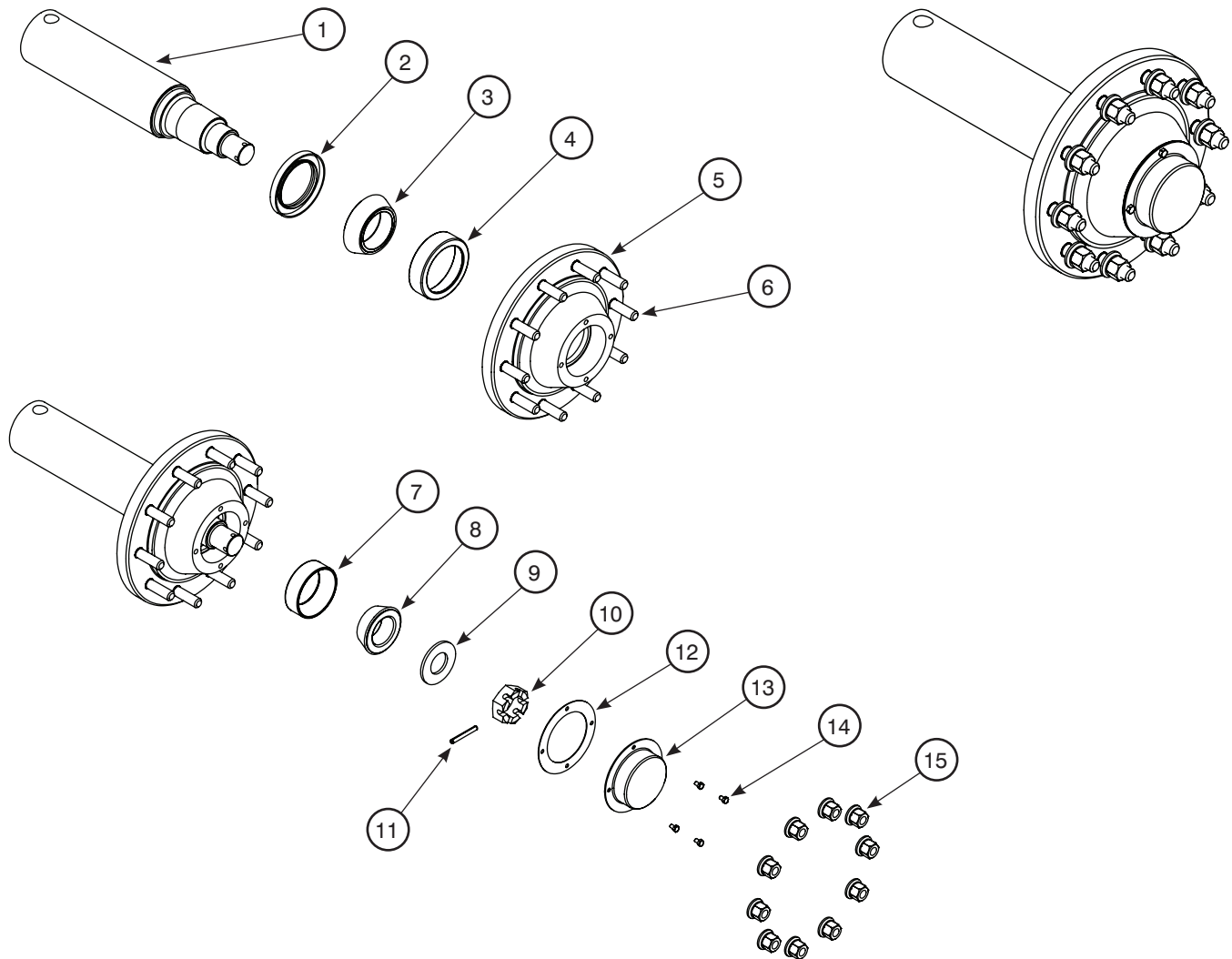

Item	Description	5" Ultra - 13 3/16" Bolt Circle		6" Ultra - 13 3/16" Bolt Circle	
		Quantity	Part Number	Quantity	Part Number
1	Spindle	1	50816	1	50826
2	Seal	1	50815	1	50825
3	Inner Taper Bearing Cone	1	21622	1	50821
4	Inner Taper Bearing Cup	1	21651	1	50819
5	Wheel Hub (with Studs and Wheel Bearing Cups)		50814		50818
6	Stud, M22-1.5 X 100mm GR8	10	50400	10	50400
7	Outer Taper Bearing Cup	1	21652	1	50820
8	Outer Taper Bearing Cone	1	21621	1	50822
9	Flat Washer	1	11814	1	50828
10	Castle Nut	1	50817	1	50827

Inner and Outer Taper Wheel Bearings

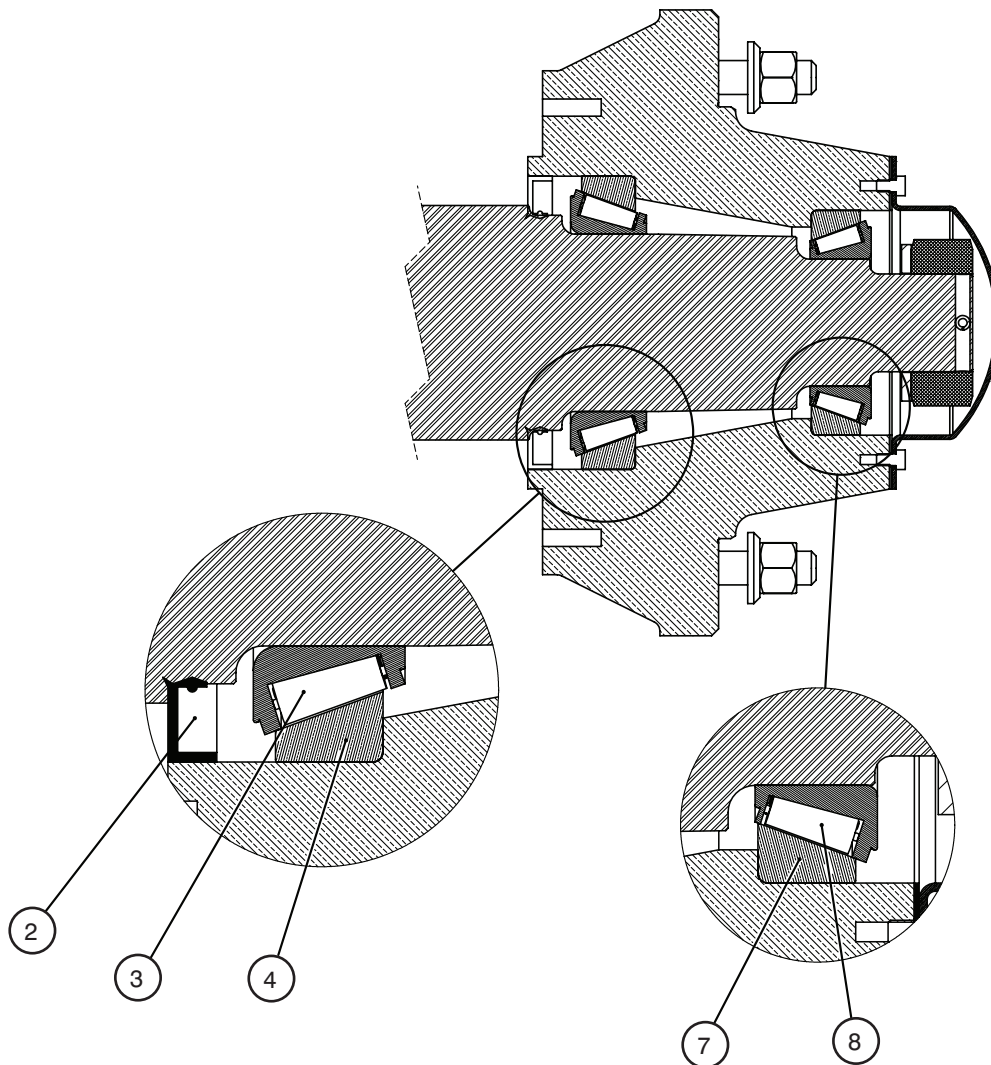

Item	Description	5" Ultra - 13 3/16" Bolt Circle		6" Ultra - 13 3/16" Bolt Circle	
		Quantity	Part Number	Quantity	Part Number
11	Locking Pin (Cotter Pin or Roll Pin)	1	81767	1	1953
12	Hub Cap Gasket	1	17147	1	50824
13	Hub Cap	1	17149	1	50823
14	Hub Cap Bolt	4	1181	4	1181
15	Lug Nut, M22 X 1.5	10	91849	10	91849
	Spindle and Wheel Hub		91834		91855
	Spindle and Wheel Hub (for Brake Rotor)		82189		82192
	Complete Spindle Assembly		91856		91857
	Complete Wheel Hub Assembly		91850		91851

Tires

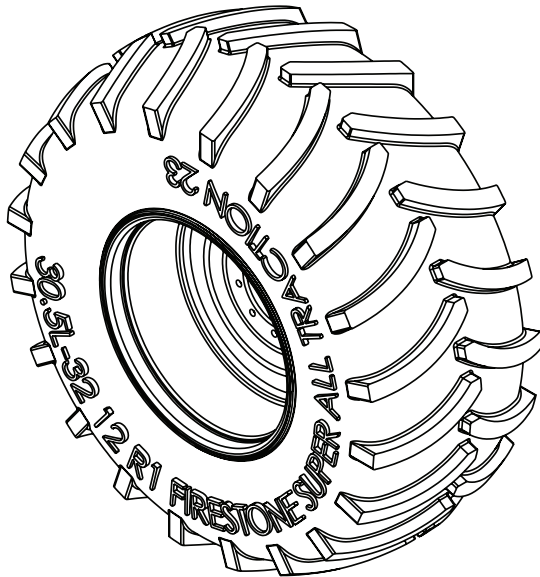

R1 - Lug

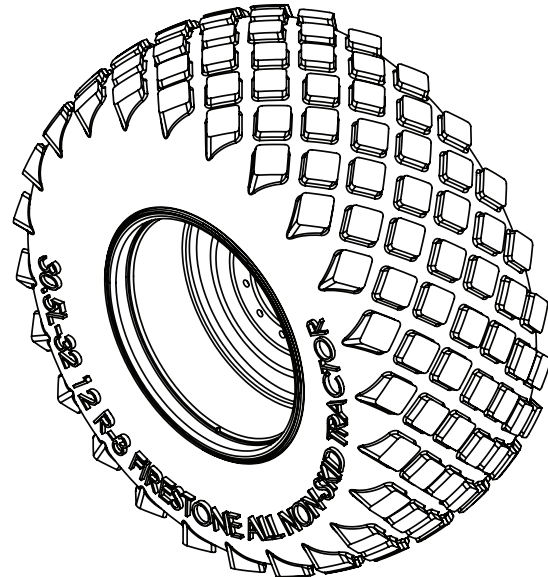

R3 - Diamond

Description	Part Number			Tire Pressure
	Tire and Rim	Tire Only	Rim Only	
28L X 26 R3 - 10 Bolt, 13 3/16" Bolt Circle	28386	17611	28387	26 (180 kPa)
28LR26 R3 - 10 Bolt, 13 3/16" Bolt Circle	91882	92639	28387	54 (372 (kPa)
30.5x32 R1 - 10 Bolt, 13 3/16" Bolt Circle	91340	91341	27385	33 (228 kPa)
30.5x32 R3 - 10 Bolt, 13 3/16" Bolt Circle	27674	22692	27385	33 (228 kPa)
30.5LR32 R1 - 10 Bolt, 13 3/16" Bolt Circle	91586	94587	27385	52 (359 kPa)
30.5LR32 R3 - 10 Bolt, 13 3/16" Bolt Circle	92640	92641	27385	52 (359 kPa)
850/50 30.5 - 10 Bolt, 13 3/16" Bolt Circle, 10 Ply	40976	40977	40978	37 (256 kPa)
900/60 32 R1 - 10 Bolt, 13 1/4" Bolt Circle	91900	91901	27385	35 (241 kPa)

BALZER

Brakes

Disc Brake Assembly

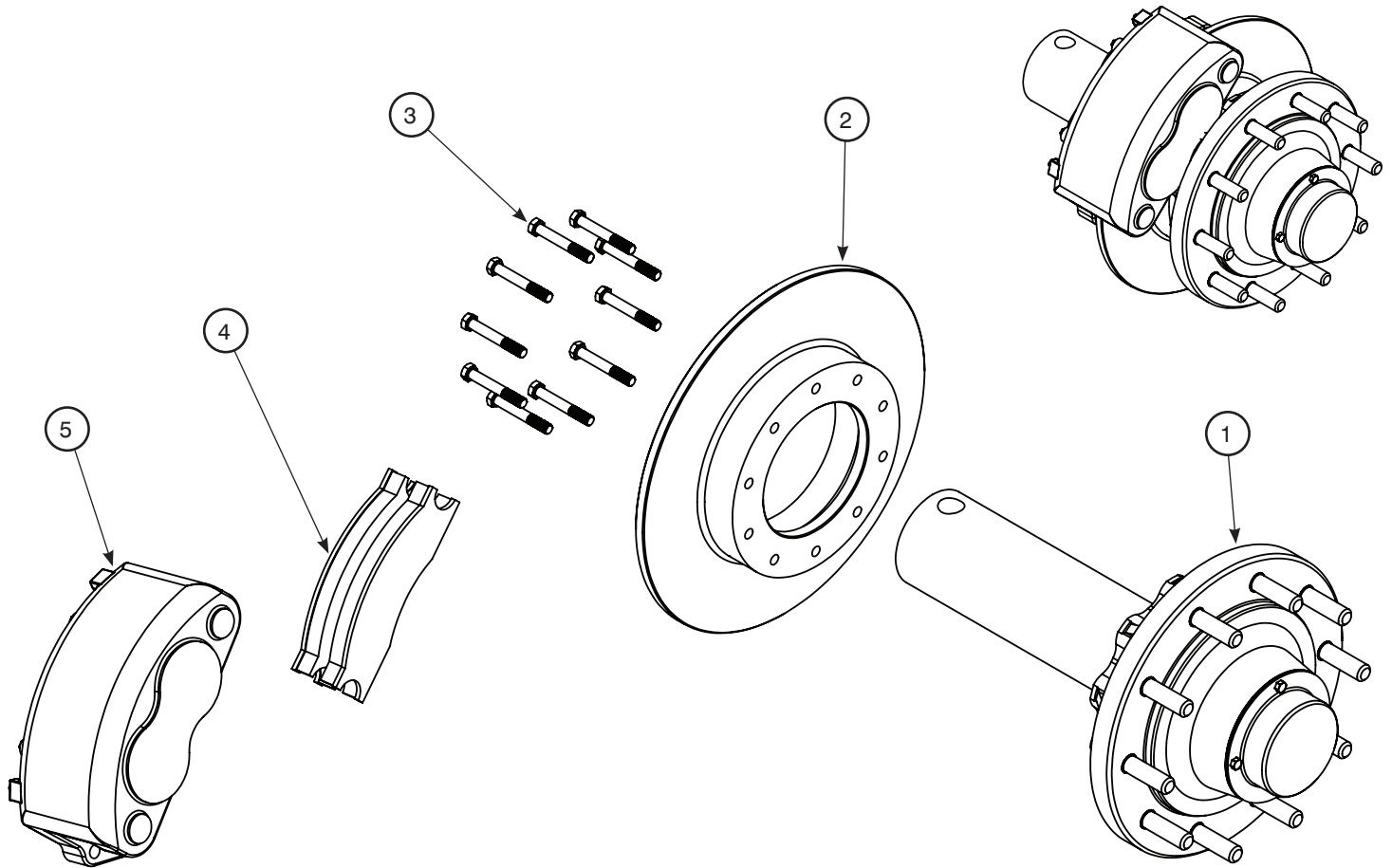

Item	Description	5" Ultra - 13 3/16" Bolt Circle		6" Ultra - 13 3/16" Bolt Circle	
		Quantity	Part Number	Quantity	Part Number
1	Spindle and Wheel Hub Assembly	1	82189	1	82192
2	Brake Rotor	1	91859	1	91858
3	Brake Rotor Bolt, 1/2"-20 X 3 1/2" GR8	10	2622	10	2622
4	Brake Pads	1 Set	52013	1 Set	52013
5	Brake Caliper	1	91853	1	91853

Hydraulic Brake Return

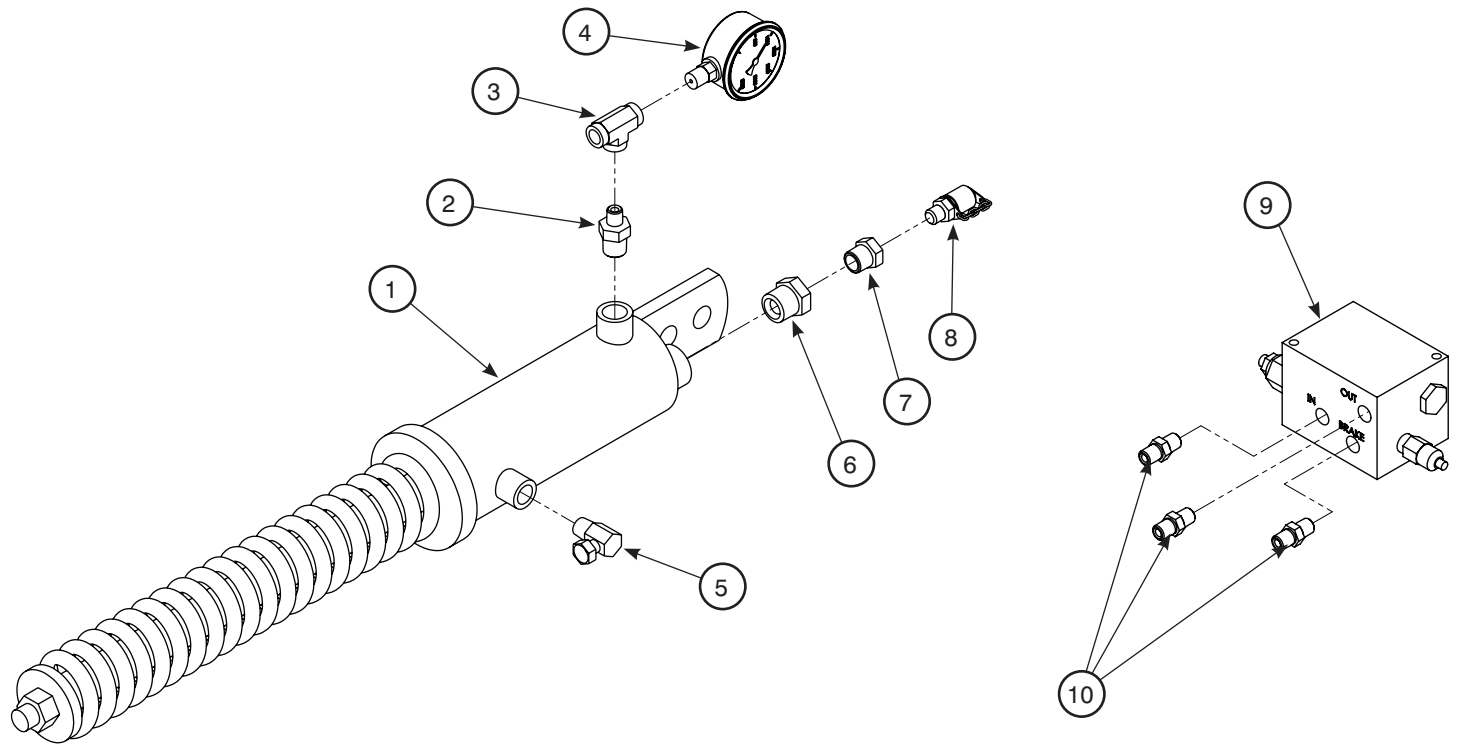

Item	Description	Quantity	Part Number
1	Brake Spring, Hydraulic	1	82548
2	Hydraulic Nipple, 1/2" NPTM X 1/4" NPTFM	1	8622
3	Hydraulic Tee, 1/4" NPTFM X 1/4" NPTFM X 1/4" NPTFM	1	9957
4	Hydraulic Pressure Gauge	1	8638
5	Hydraulic Elbow, 3/8" NPTM X 1/4" NPTFMS, 90°	1	21171
6	Hydraulic Reducer, 3/4" NPTM X 1/2" NPTFM	1	8622
7	Hydraulic Reducer, 1/2" NPTM X 1/4" NPTFM	1	12190
8	Hydraulic Test Point with Cap	1	37521
9	Hydraulic Brake Valve Manifold	1	82550
10	Hydraulic Nipple, 1/4" NPTM X 1/4" NPTM	3	21664

Hydraulic Brake Return

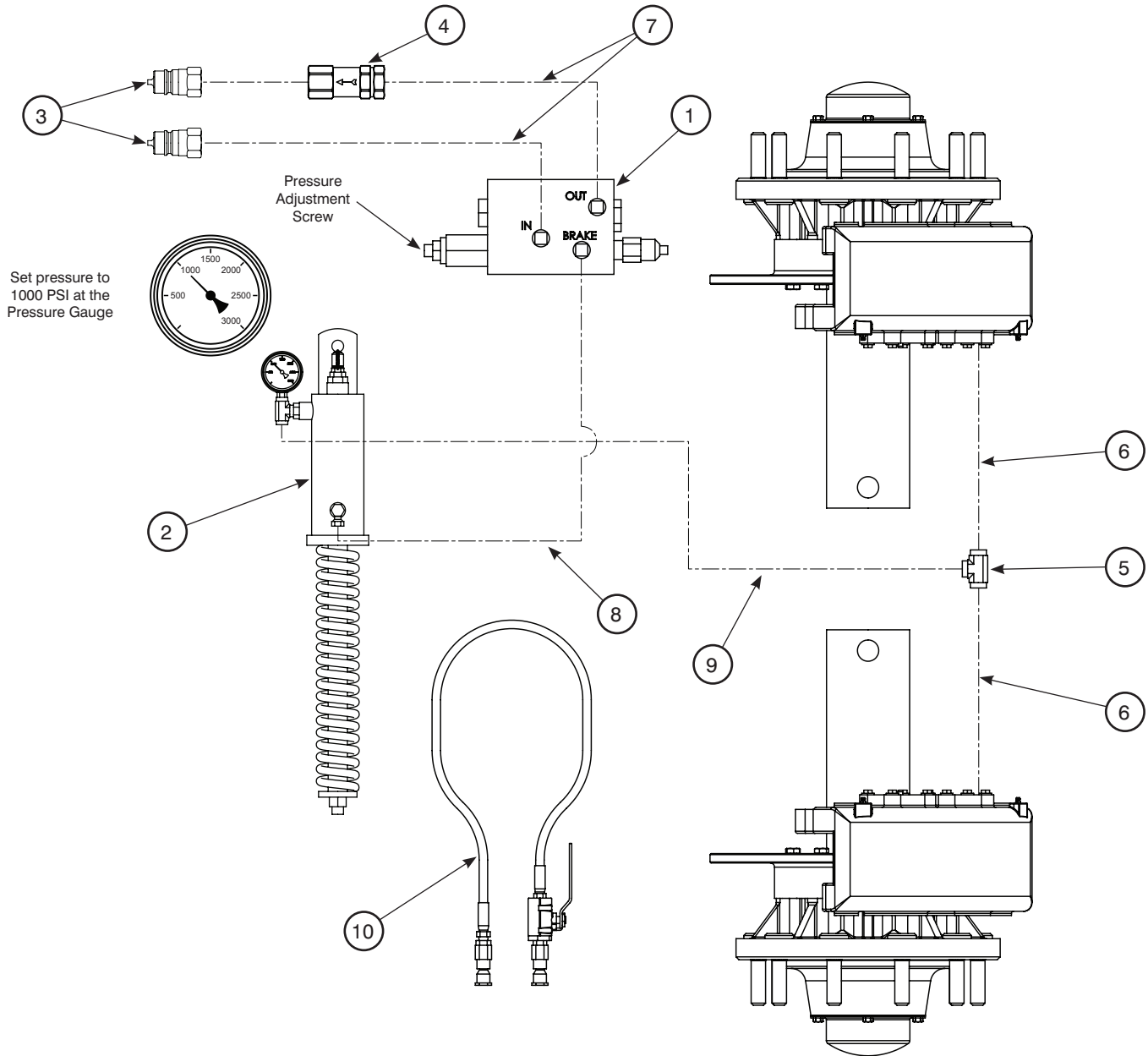

Item	Description	Quantity	Part Number
1	Hydraulic Brake Valve Manifold Assembly	1	
2	Hydraulic Brake Spring Assembly	1	
3	Coupler, Quick Connect, 1/2" NPTM	2	8634
4	Hydraulic Check Valve, 1/2" NPTFM X 1/2" NPTFM	1	10459
5	Hydraulic Tee, 1/4" NPTFM X 1/4" NPTFM X 1/4" NPTFM	1	36069
6	Hydraulic Hose Line, 1/4" NPTFM X 1/4" NPTMS, 84" LONG	2	22201
7	Hydraulic Hose Line, 1/4" NPTFM X 1/4" NPTMS, 144" LONG	2	13893
8	Hydraulic Hose Line, 1/4" X 9/16" JICFMS X 9/16" JICFMS 90°, 36" LONG	1	852036
9	Hydraulic Hose Line, 1/4" X 9/16" JICFMS X 9/16" JICFMS 90°, 132" LONG	1	852132
10	Bleeder Hose	1	72182

BALZER

Electrical

Light Location

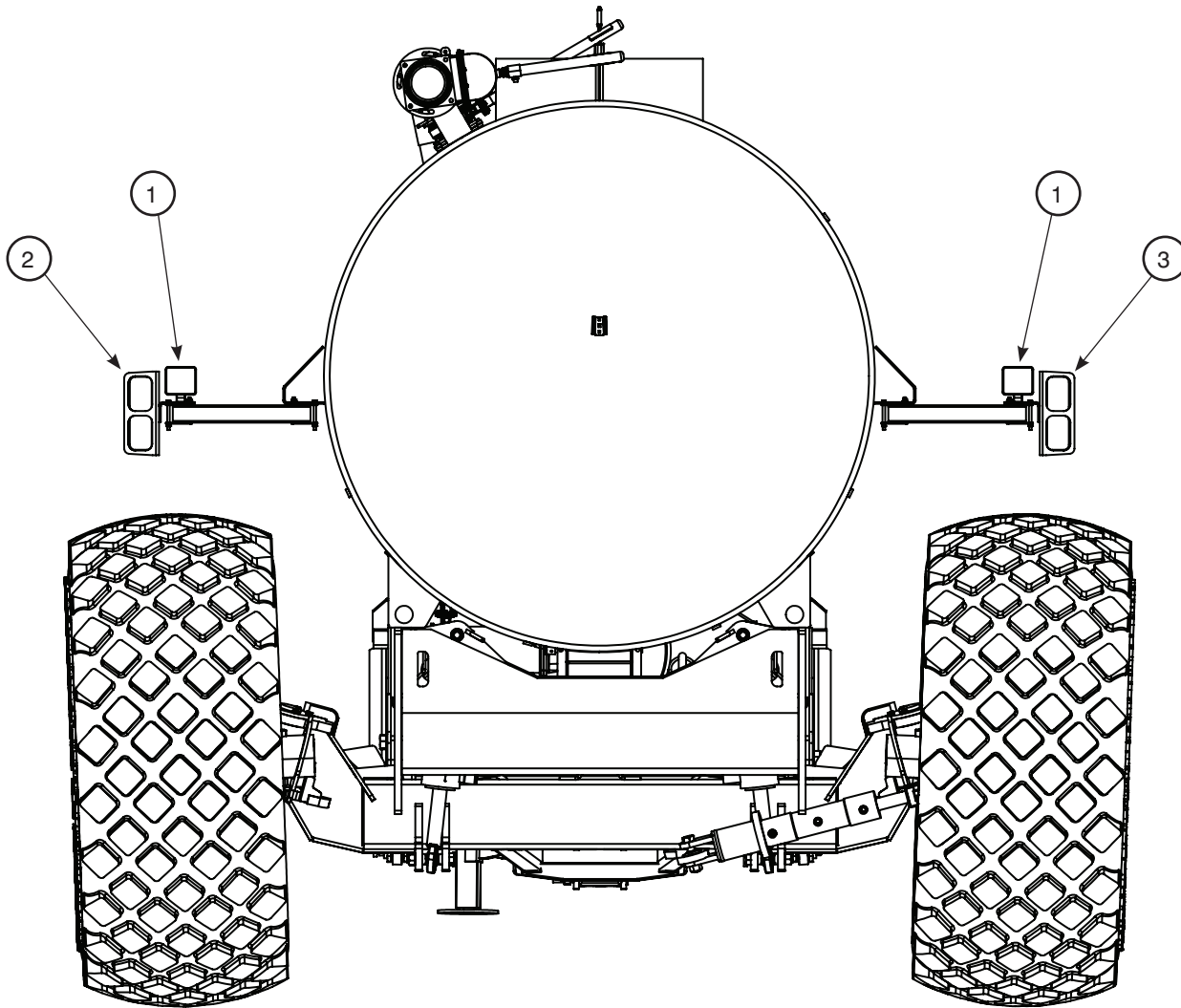

Item	Description	Quantity	Part Number
1	Work Light, LED	2	60984
2	Turn Light Assembly, Left	1	40763
3	Turn Light Assembly, Right	1	40764

ELECTRICAL

Lighting Assemblies

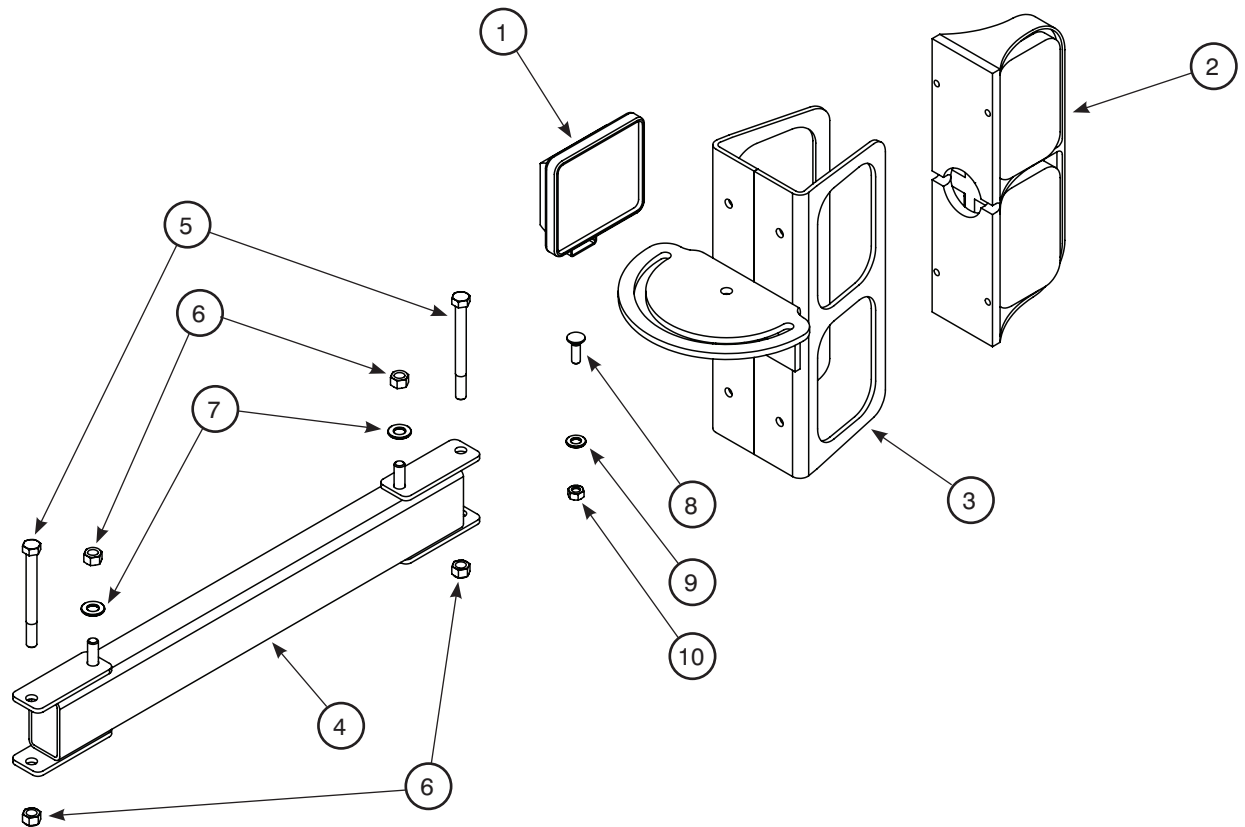

Item	Description	Quantity *	Part Number
1	Work Light, LED	1	60984
2	Turn Light Assembly, Right	1	40764
	Turn Light Assembly, Left		40763
3	Light Bracket Weldment	1	72786
4	Light Kit Arm, 21 3/4"	1	85769
5	Bolt, Hex Head, 3/8"-16 X 4", GR5	2	1218
6	Nut, Top Lock, 3/8"-16, GR5	4	2496
7	Flat Washer, 3/8"	2	1598
8	Carriage Bolt, 5/16"-18 X 1", GR5	1	1025
9	Flat Washer, 5/16"	1	1597
10	Nut, 5/16"-18	1	1691

* Quantity is for each Light Arm Assembly

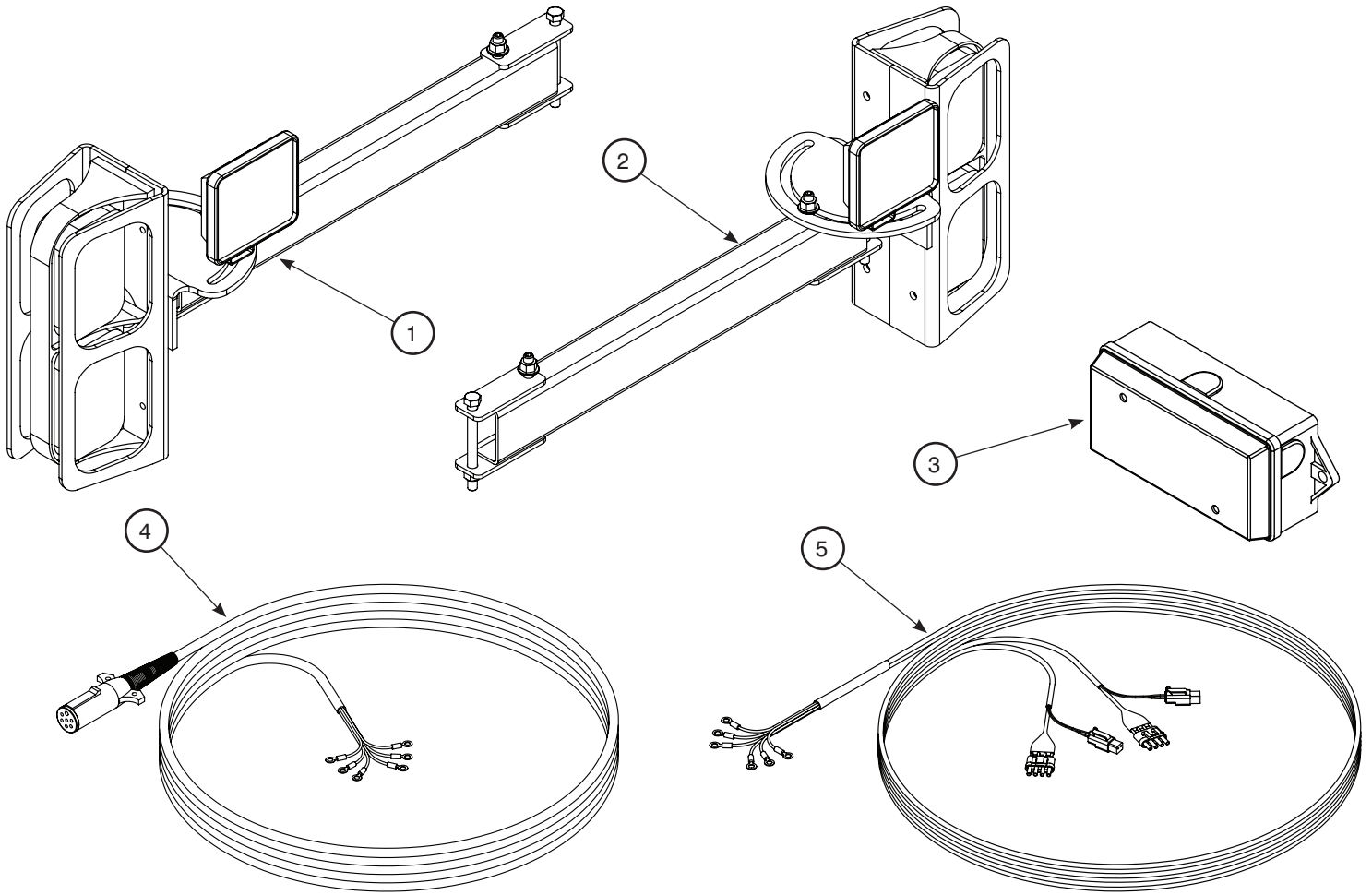

Item	Description	Quantity	Part Number
1	Light Kit, Left	1	72785
2	Light Kit, Right	1	72786
3	Junction Box, 7-Way	1	72663
4	Wiring Harness, Front	1	34171
5	Wiring Harness, Rear	1	34159

Junction Box Wiring Diagram

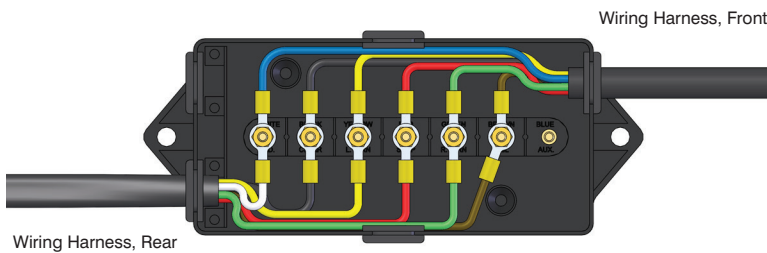

Wiring Harness, Rear		Wiring Harness, Front
Wire Color	Purpose	Wire Color
White	Ground	Blue or White*
Black	Work Lights	Black
Yellow	Left Turn Signal	Yellow
Red	Brake Lights	Red
Green	Right Turn Signal	Green
Brown	Tail Lights	Brown

* Must be connected to Ground (Pin 1) on 7-Way Connector
See Next Page for 7-Way Connector Wiring

ELECTRICAL

Wiring Diagram

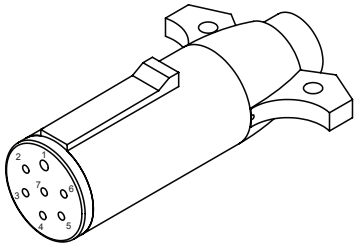

7-Way Plug
(Part # 27701)

7-Way Plug Terminal Wiring		
Pin	Wire Color	Usage
1	White or Blue	Ground
2	Black	Work Lights
3	Yellow	Left Turn Signal
4	Red	Brake Lights
5	Green	Right Turn Signal
6	Brown	Running/Tail Lights
7		Not Used

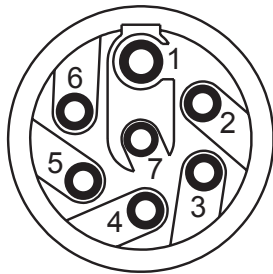
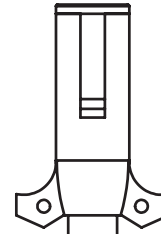

7-Way Plug
Wire Terminals

Left Turn Light Assembly
(Part # 40763)

Pin	Wire Color
1	Brown
2	Yellow
3	White
4	Red

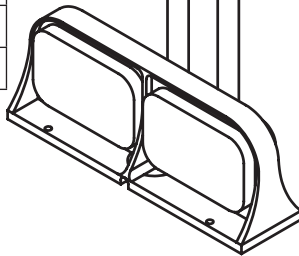

Right Turn Light Assembly
(Part # 40764)

Pin	Wire Color
1	Brown
2	Green
3	White
4	Red

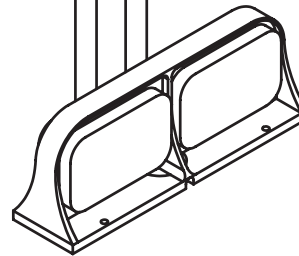

LED Work Light
(Part # 60984)

Pin	Wire Color
1	White or Blue
2	Black
3	Black
4	Red

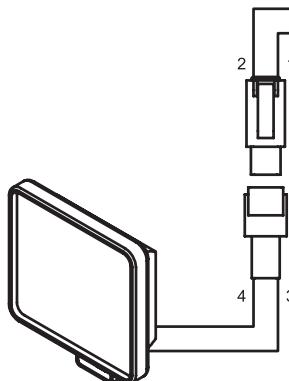

LED Work Light
(Part # 60984)

Pin	Wire Color
1	White or Blue
2	Black
3	Black
4	Red

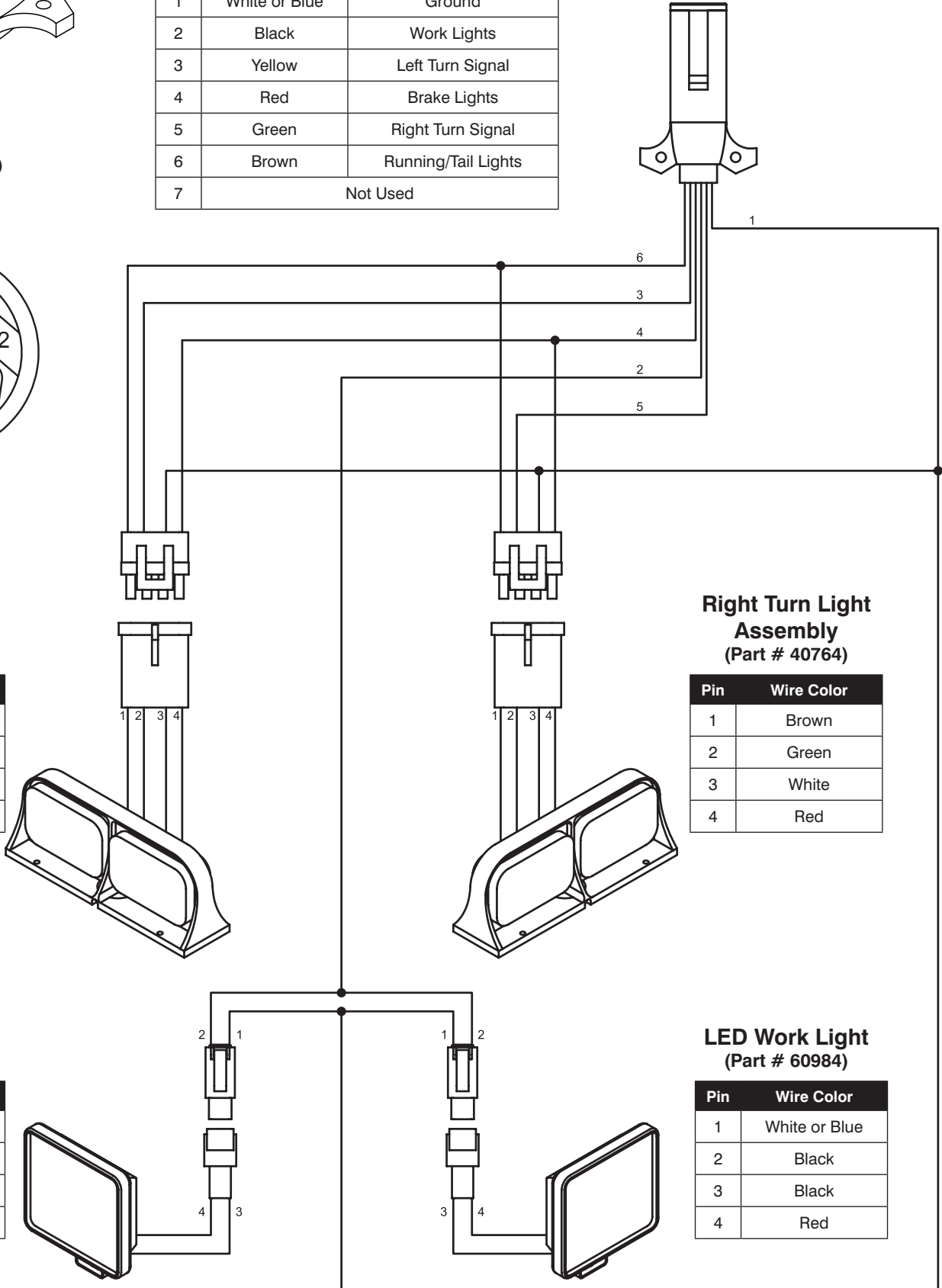
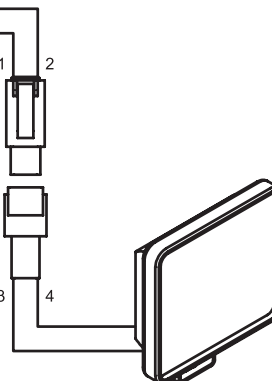

BALZER

Slurry Tank

Float

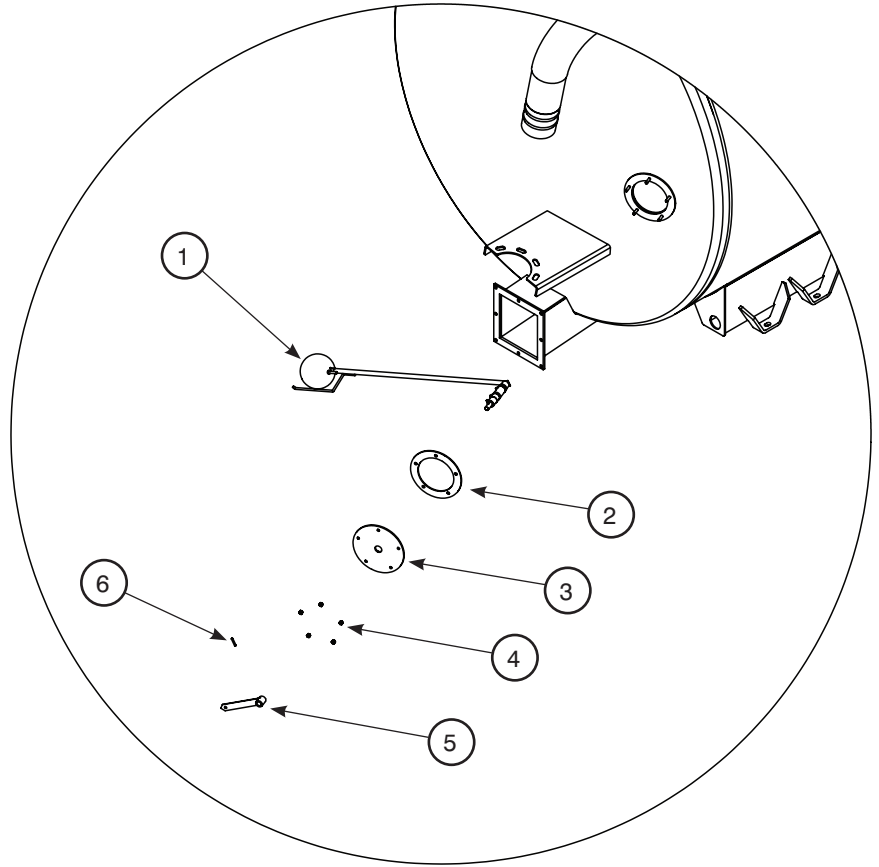
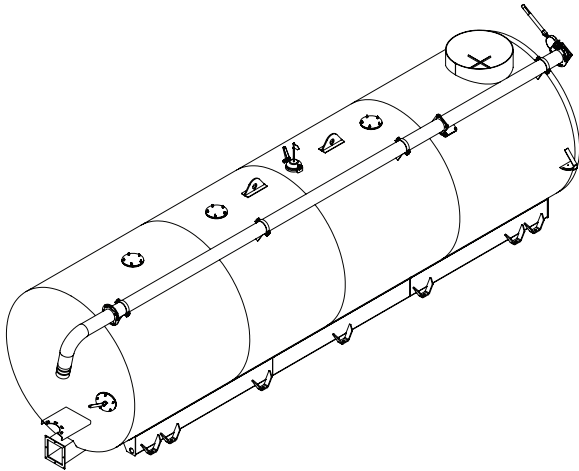

Item	Description	Quantity	Part Number
1	Float Assembly, Ball	1	22807
2	Gasket	1	15961
3	Cover	1	15904
4	Flange Nut, 3/8"-16 GR5	5	2082
5	Needle, Level Indicator	1	10949
6	Roll Pin, 1/4" x 1 1/2"	1	1908

SLURRY TANK

Top Caps and Seals

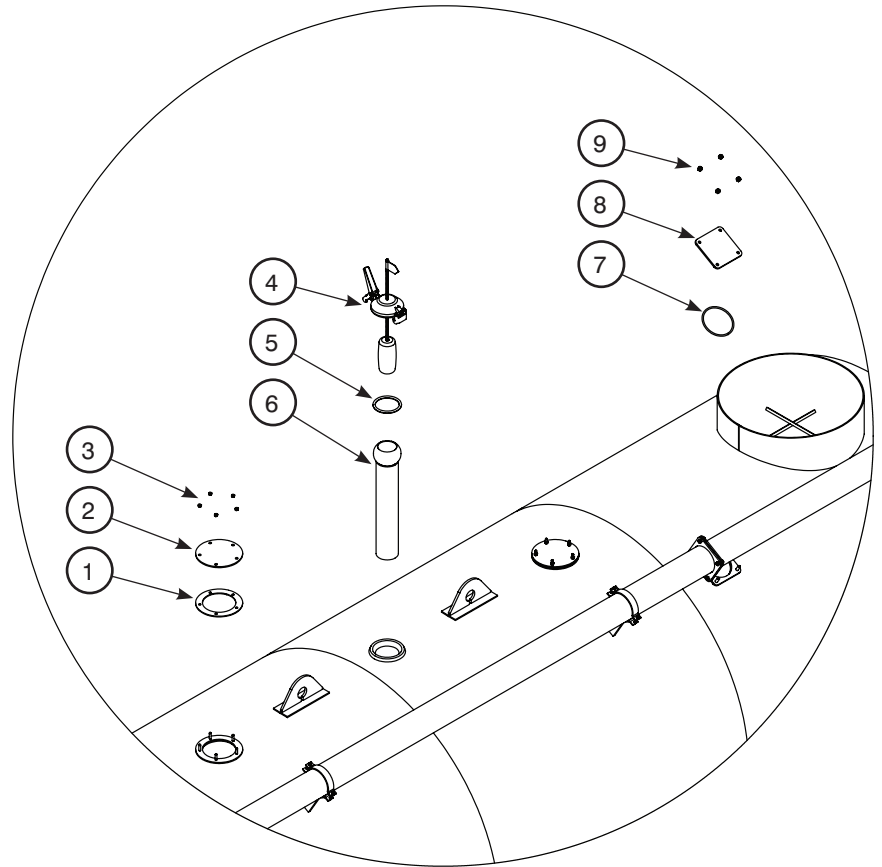
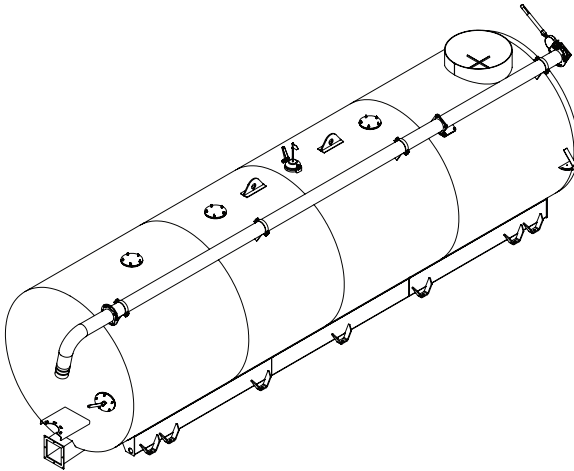

Item	Description	Quantity	Part Number
1	Gasket	2	15961
2	Cover	2	17354
3	Flange Nut, 3/8"-16 GR5	10	2082
4	Indicator, Full Capacity	1	18560
5	O-ring Seal, 4 13/16" ID X 1/2" TH	1	10913
6	Weldment, Full Indicator Tube	1	11872
7	O-ring, AS568-438	1	15621
8	Cap, Recirculation Port	1	15785
9	Nut, Hex, 1/2"-20	4	1704

Discharge Tube

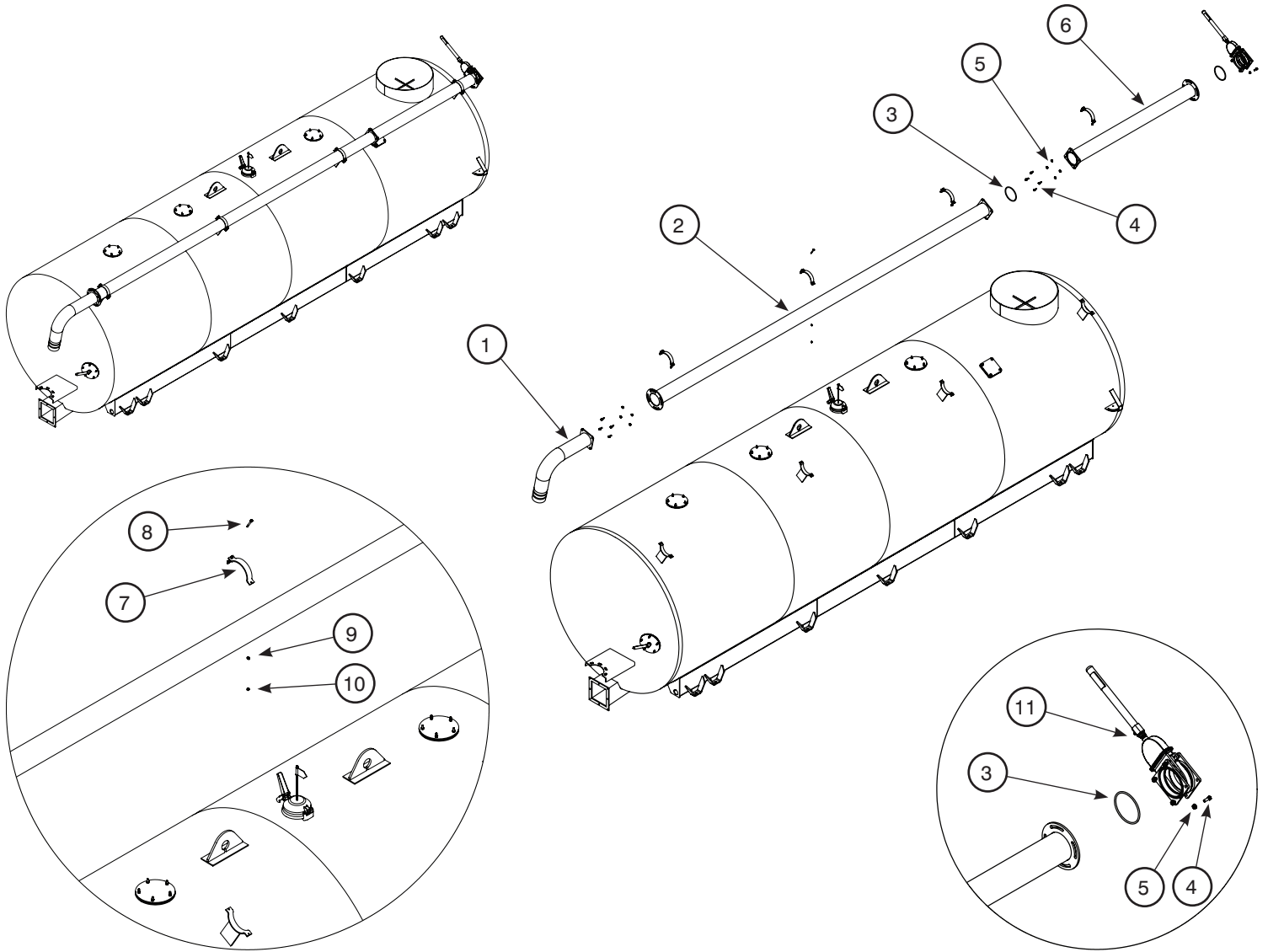

Item	Description	Quantity	Part Number
1	Fitting, 6" Hose Barb, 25 1/4" Long, 90°	1	15924
2	Discharge Tube, 6" X 275 3/4"	1	102010
3	O-ring, AS568-438	3	15621
4	Bolt, Hex Head, 1/2"-13 X 1 1/4" GR8	12	2656
5	Flange Nut, 1/2"-13	12	2081
6	Discharge Tube, 6" X 110 1/4"	1	166000
7	Bracket, Discharge Tube	5	15870
8	Bolt, Hex Head, 5/16"-18 X 2 3/4" GR5	10	1192
9	Flat Washer, 5/16"	10	1597
10	Hex Nut, 5/16"-18	10	1691
11	Valve, 6" Gate, 2" Flange	1	15678

SLURRY TANK

Recirculation Connection (Optional)

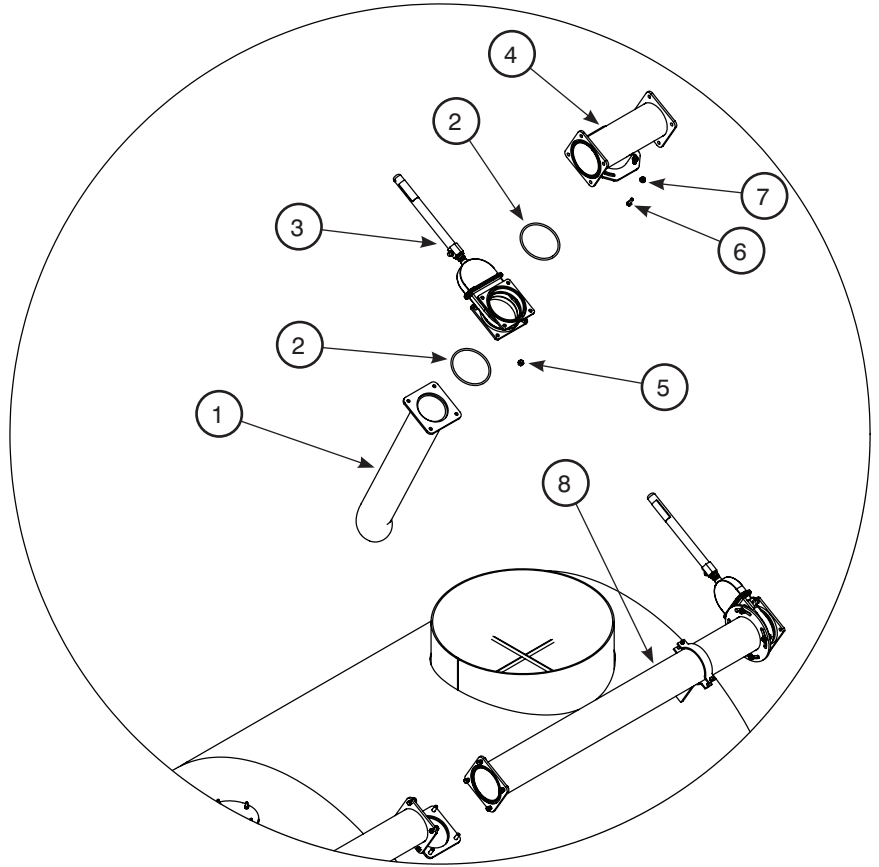
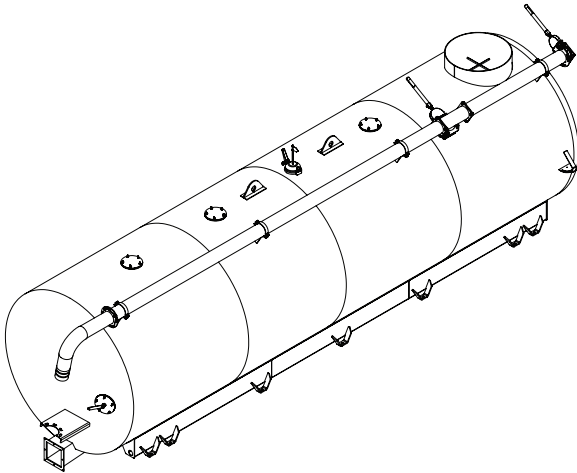

Item	Description	Quantity	Part Number
1	Intake Elbow, w/Flange and Piping	1	102009
2	O-ring, AS568-438	4	15621
3	Valve, 6" Gate, 2" Flange	1	15678
4	Discharge Tube, Tee, 6" X 16"	1	94650
5	Nut, Hex, 1/2"-20	4	1704
6	Bolt, Hex Head, 1/2"-13 X 1 1/4" GR8	4	1249
7	Flange Nut, 1/2"-13	4	2084
8	Discharge Tube, 6" X 60 1/4"	1	102012

BALZER

Slurry Pump

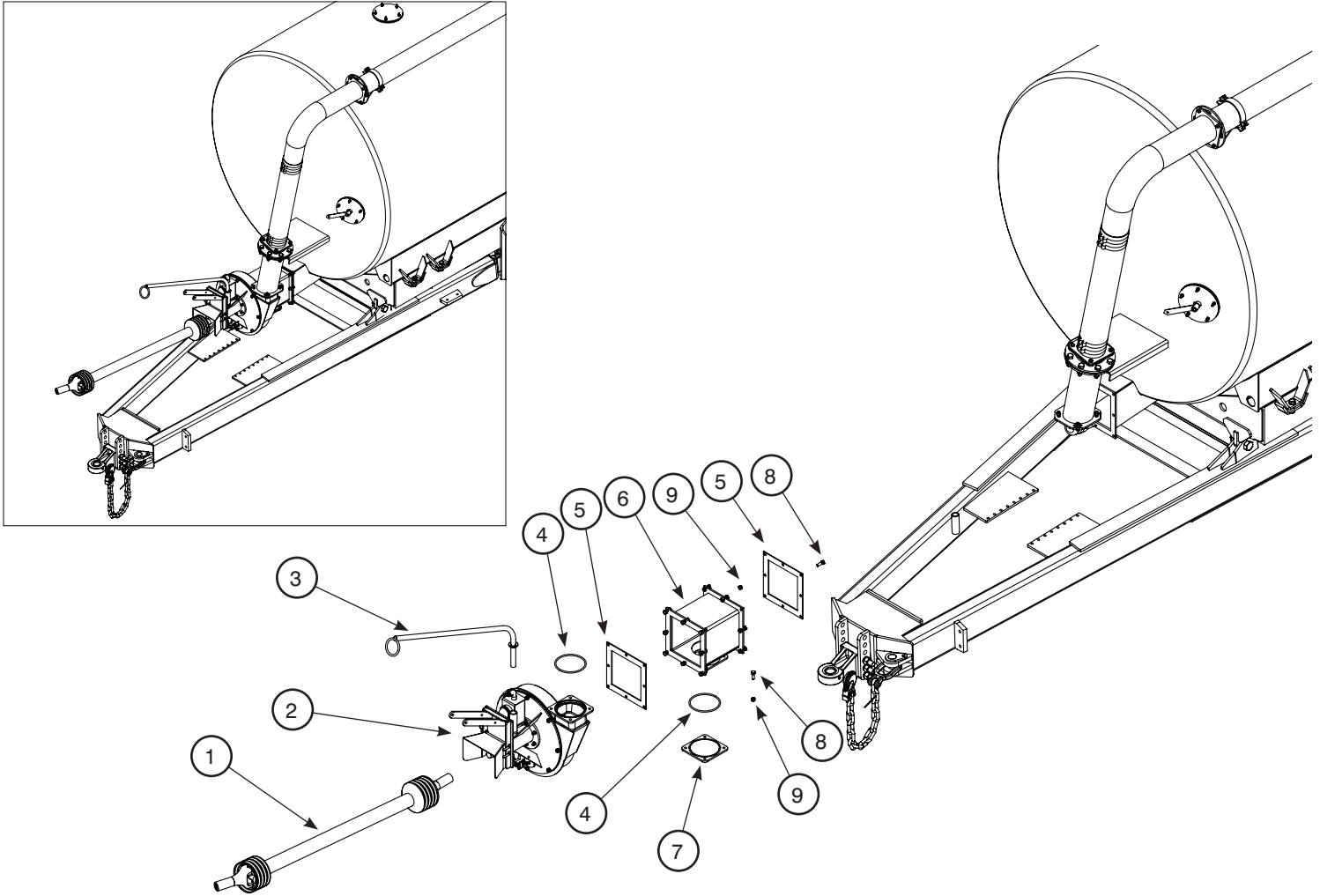

Item	Description	Quantity	Part Number
1	PTO Shaft, 1 3/8"-21 to 1 1/2" Round with 3/8" Keyway (Standard)	1	37492
	PTO Shaft, 1 3/4"-20 to 1 1/2" Round with 3/8" Keyway (Optional)		37491
	PTO Shaft, CV 1 3/4"-20 to 1 1/2" Round with 3/8" Keyway (Optional)		37512
	PTO Shaft, CV 1 3/8"-21 to 1 1/2" Round with 3/8" Keyway (Optional)		37658
2	Pump Assembly	1	83723
3	Hose Hanger	1	83078
4	O-ring, AS568-438	2	15621
5	Gasket, 12" X 12"	2	16036
6	Sump Extension, 12"	1	91796
7	Cover, 7 1/2" X 7 1/2"	1	15785
8	Bolt, Hex Head, 1/2"-13 X 1 1/2" GR5	20	1250
9	Flange Nut, 1/2"-13 GR5	20	2084

SLURRY PUMP

Pump

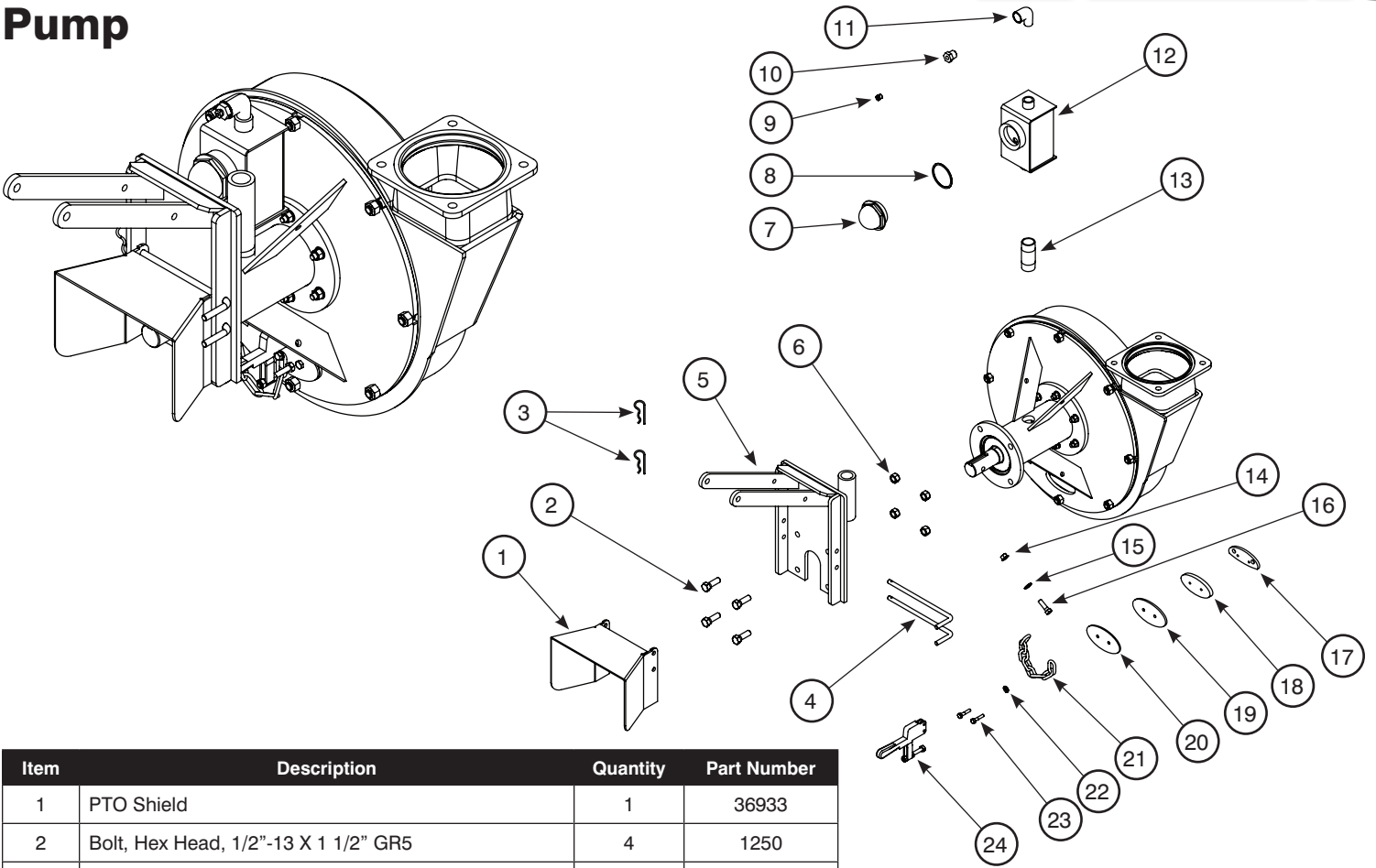

Item	Description	Quantity	Part Number
1	PTO Shield	1	36933
2	Bolt, Hex Head, 1/2"-13 X 1 1/2" GR5	4	1250
3	Hairpin Cotter Pin, 1/8" X 2 3/4"	2	2611
4	Pin, 3/8" X 7 9/16" Working Length	2	83079
5	Support Bracket, Shield and PTO	1	83075
6	Nut, Top Lock, 1/2"-13 GR5	4	2539
7	Sight Glass, 2" NPT	1	4061
8	O-ring, AS568-229	1	4062
9	Breather, 1/8" NPT, Brass	1	13097
10	Reducer, 1/2" NPTM X 1/8" NPTFM	1	13038
11	Pipe, Elbow, 1/2" NPTM X 1/2" NPTFM, 90°	1	8215
12	Oil Reservoir	1	36930
13	Pipe Nipple, 1" NPTM X 1" NPTM X 3"	1	36065
14	Flange Nut, 3/8"-16	1	2082
15	Flat Washer, 3/8"	1	1598
16	Bolt, Hex Head, 3/8"-16 X 1 1/4" GR5	1	1207
17	Inner Drain Plug	1	71877
18	Outer Drain Plug	1	71876
19	Drain Plug Gasket, 3/16" Neoprene	1	71887
20	Outer Cover, Drain Plug	1	71888
21	Chain, 5/0 Straight Link	1	71896
22	Flat Washer, 1/4"	1	1596
23	Bolt, Hex Head, 1/4"-20 X 1 1/4" GR5	2	1165
24	Toggle Clamp with 5/16"-18 Bolt and Nuts	1	33001

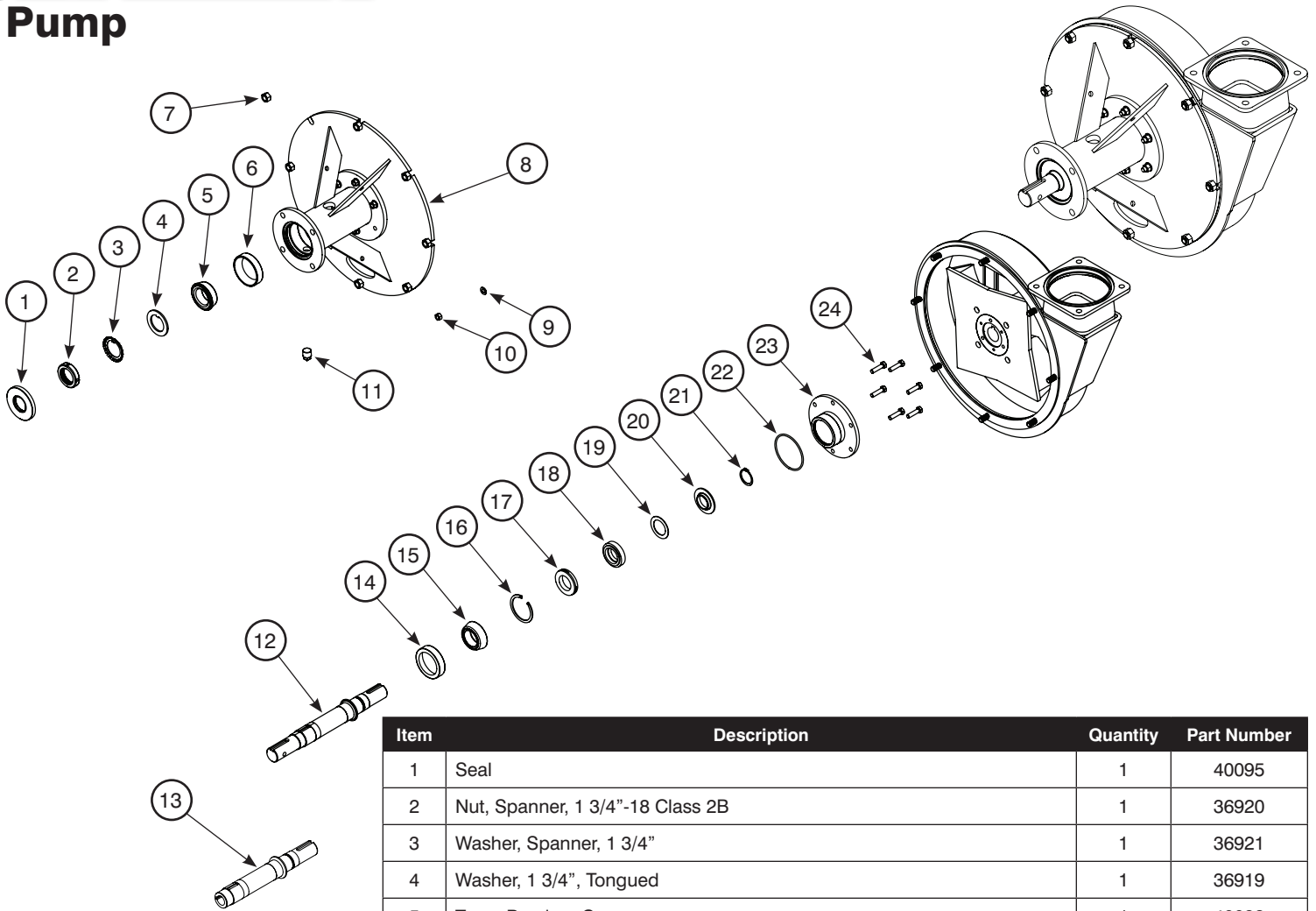

Item	Description	Quantity	Part Number
1	Seal	1	40095
2	Nut, Spanner, 1 3/4"-18 Class 2B	1	36920
3	Washer, Spanner, 1 3/4"	1	36921
4	Washer, 1 3/4", Tongued	1	36919
5	Taper Bearing, Cone	1	40098
6	Taper Bearing, Cup	1	8491
7	Nut, Top Lock, 1/2"-13 GR8	8	2539
8	Seal Chamber Housing	1	36909
9	Flat Washer, 3/8"	6	1598
10	Nut, Top Lock, 3/8"-16 GR8	6	2496
11	Plug, 1/2"-14 NPTF, Square Head	1	8907
12	Pump Shaft, PTO (Standard)	1	81758
13	Pump Shaft, Hydraulic (Optional - Use with Hydraulic Pump, Page 58)	1	83719
14	Taper Bearing, Cup	1	8491
15	Taper Bearing, Cone	1	40098
16	Snap Ring, Internal, 68mm X 2.4mm	1	6509
17	Seal, Mechanical Rotating, 40mm, Front	1	17945
18	Seal, Mechanical Rotating, 40mm, Back	1	17941
19	Shim, 1 5/8" ID X 18ga	1	61441
20	Splash Guard, 40mm	1	17054
21	Snap Ring, External, 40mm X 1.6mm	1	6506
22	O-ring, AS568-239	1	36918
23	Cap, Slurry Seal	1	81290
24	Bolt, Hex Head, 3/8"-16 X 1 1/2" GR5	6	1208

SLURRY PUMP

Pump

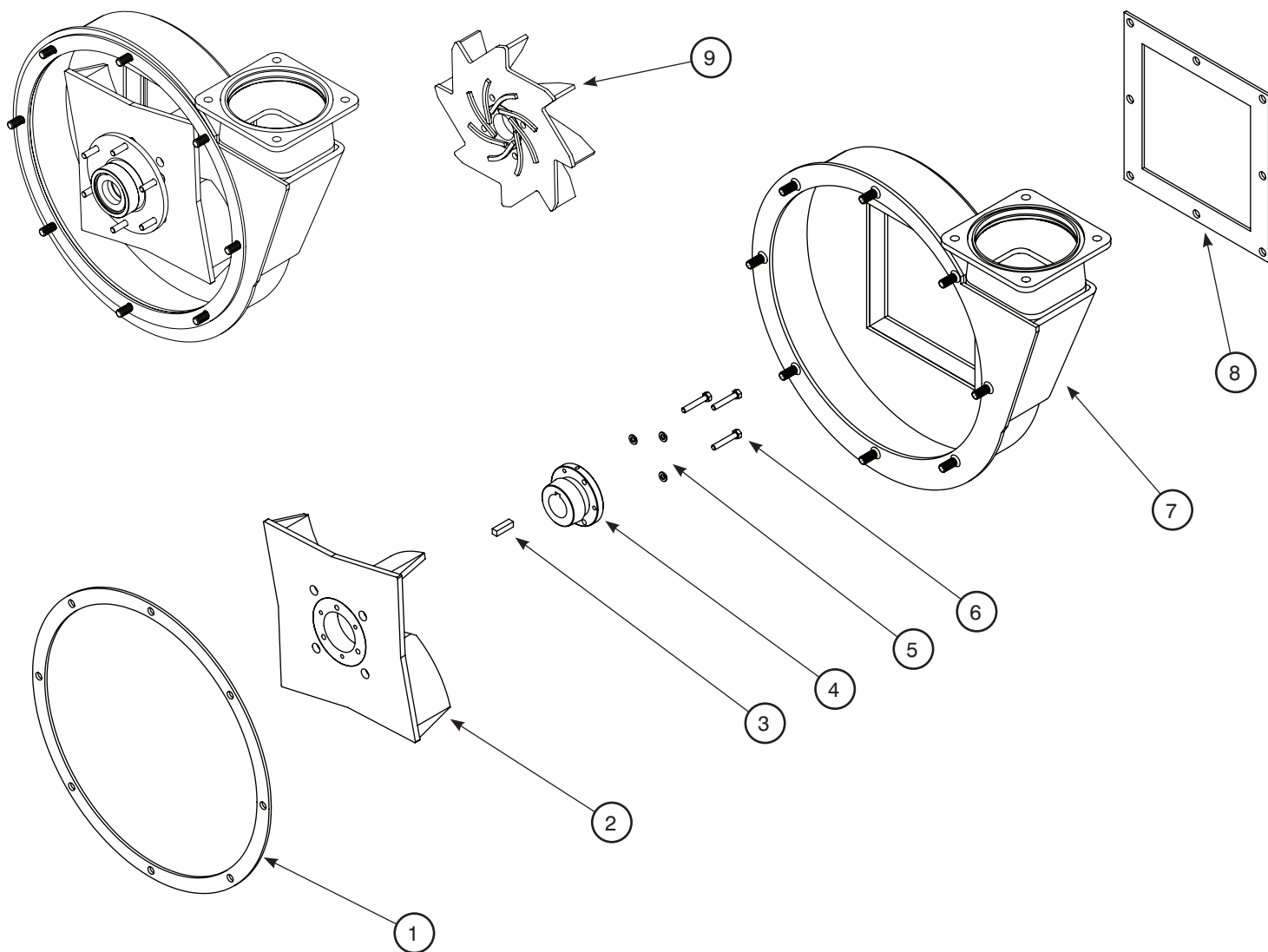

Item	Description	Quantity	Part Number
1	Gasket, Rubber, 19 5/8" OD X 3/16" TH	1	16034
2	Impeller, 4-Blade, 15" (Standard)	1	81300
3	Key, 3/8" X 3/8" X 1 3/8"	1	2400
4	QD Bushing	1	81770
5	Split Lock Washer, 5/16"	3	1635
6	Bolt, Hex Head, 5/16"-18 X 1 7/8", Stainless Steel	3	18911
7	Magnum Pump Housing	1	71931
8	Gasket, 12" X 12"	1	16036
9	Impeller, 8-Blade, 17 1/2" (Optional)	1	33049

Hydraulic Drive (Optional)

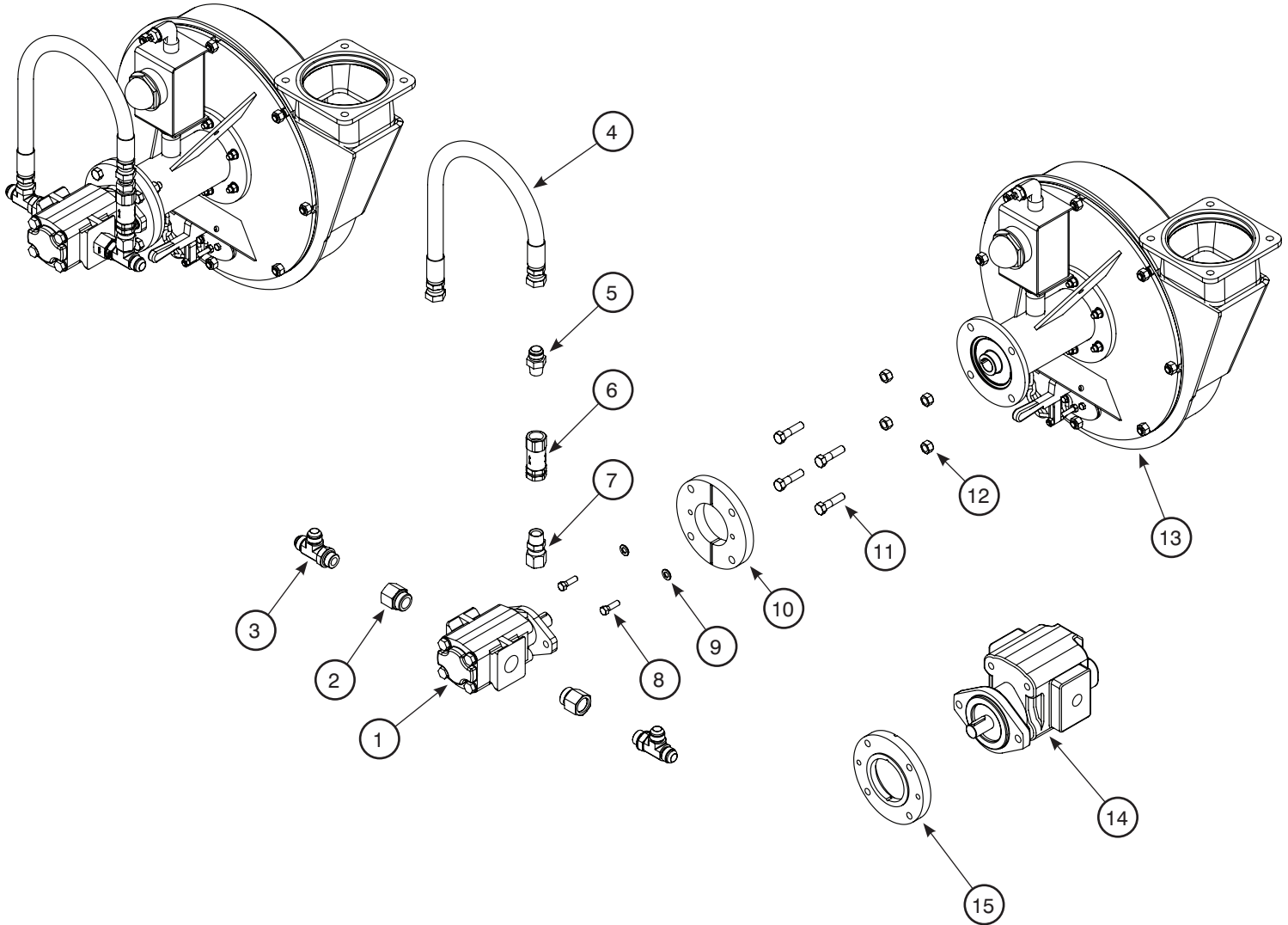

Item	Description	Quantity	Part Number
1	Hydraulic Motor, 3.94 CU IN (Standard)	1	20474
2	Hydraulic Reducer, 1 5/16" ORB X 1 1/16" ORB	2	839012
3	Hydraulic Tee, 1 1/16" JICM X 1 1/16" ORB X 1 1/16" JICM	2	849006
4	Hydraulic Hose, 3/4" x 1 1/16" JICFMS X 1 1/16" JICFMS, 24" Long	1	857025
5	Hydraulic Nipple, 1 1/16" JIC X 3/4" NPTM	1	839008
6	Hydraulic Check Valve, 3/4" NPTFM X 3/4" NPTFM	1	8893
7	Hydraulic Coupler, 1 1/16" JICFM X 3/4" NPTM	1	839007
8	Bolt, Hex Head, 3/8"-16 X 1 1/4" GR5	2	1207
9	Flat Washer, 3/8"	2	1598
10	Hydraulic Motor Mount, Slurry Pump - 3.94 CU IN Hydraulic Motor (Standard)	1	36917
11	Bolt, Hex Head, 1/2"-13 X 2" GR5	4	1252
12	Nut, Top Lock, 1/2"-13	4	2539
13	Slurry Pump with Hydraulic Motor Drive Shaft (See Page 56)	1	
14	Hydraulic Motor, 6.35 CU IN (Optional)	1	33316
15	Hydraulic Motor Mount, Slurry Pump - 6.35 CU IN Hydraulic Motor (Optional)	1	41456

SLURRY PUMP

Discharge System

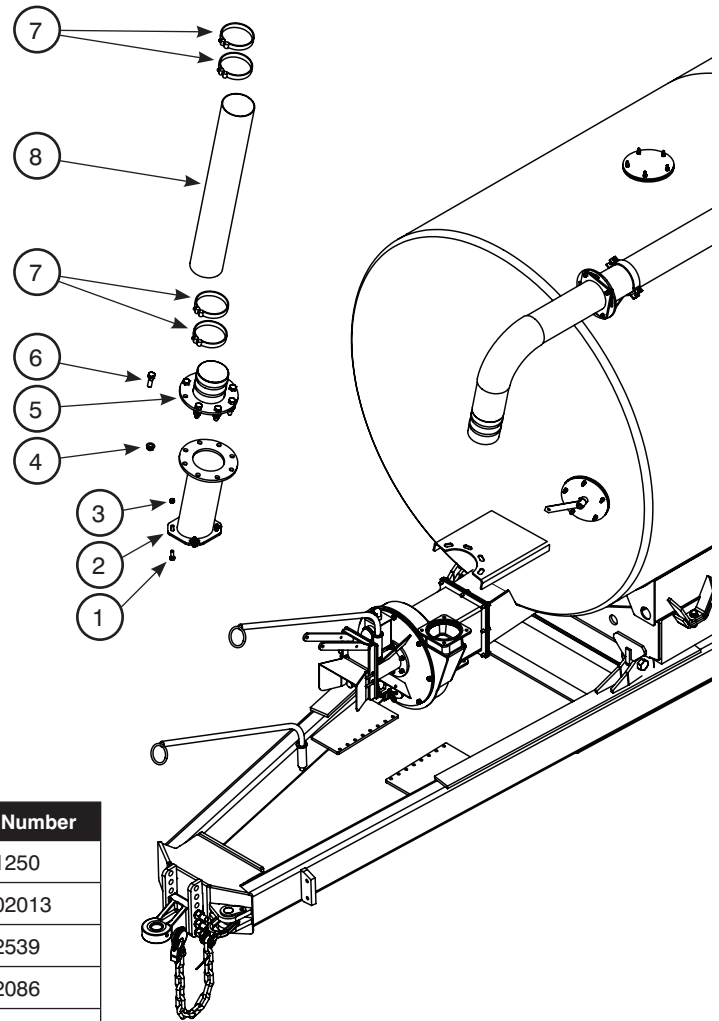
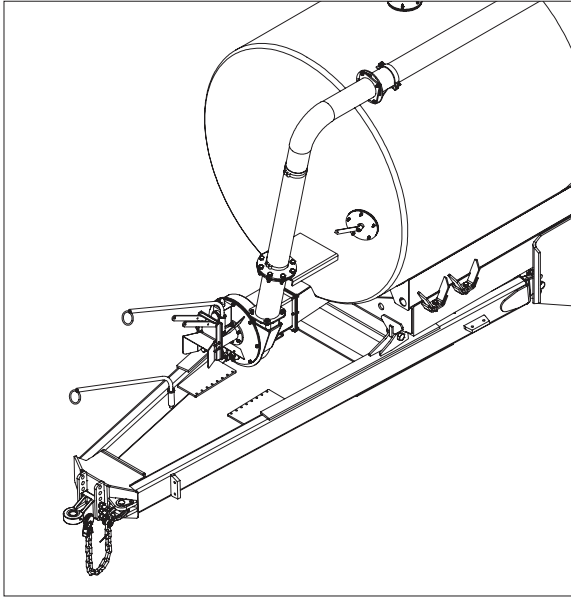

Item	Description	Quantity	Part Number
1	Bolt, Hex Head, 1/2"-13 X 1 1/2" GR5	4	1250
2	Transition Tube	1	102013
3	Flange Nut, 1/2"-13 GR5	4	2539
4	Flange Nut, 3/4"-10 GR5	16	2086
5	Pipe Extension, 8-Hole to Hose Barb, 6"	1	86030
6	Bolt, Hex Head, 3/4"-10 X 3" GR5	4	1315
7	Hose Clamp, 144-166mm	4	16009
8	Hose, Layflat, 6" X 42", Brick Red	1	14454

Discharge System with Optional Rite Rate Flow Control

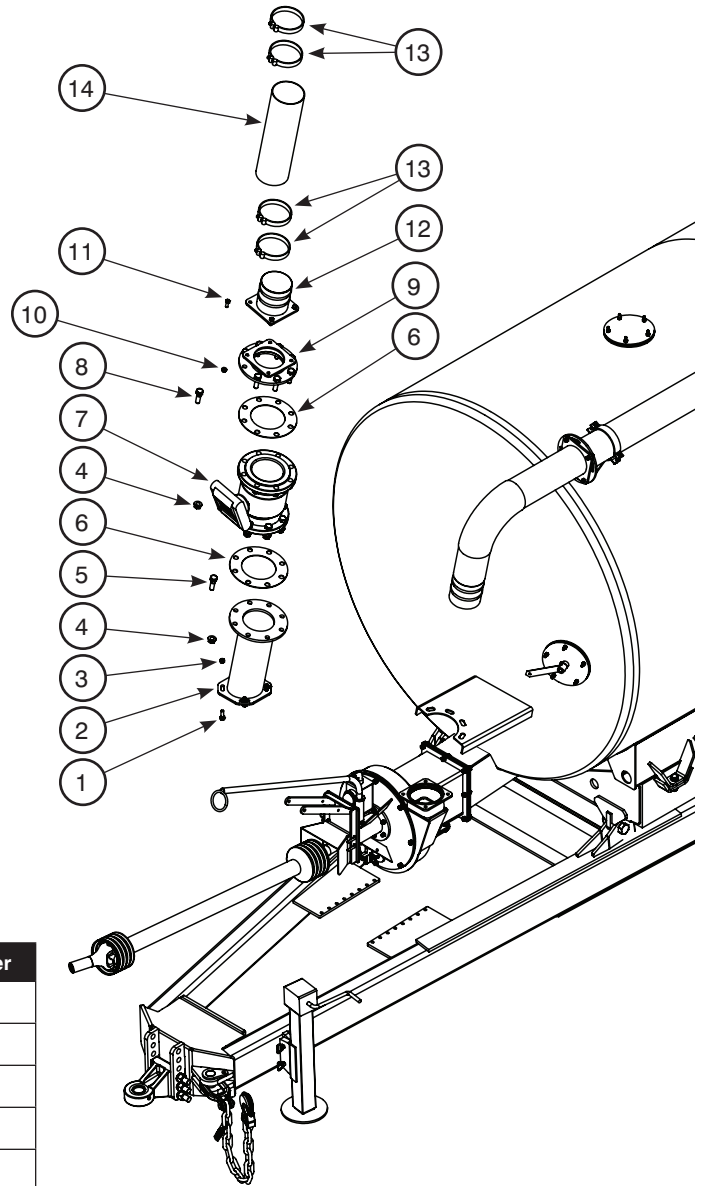
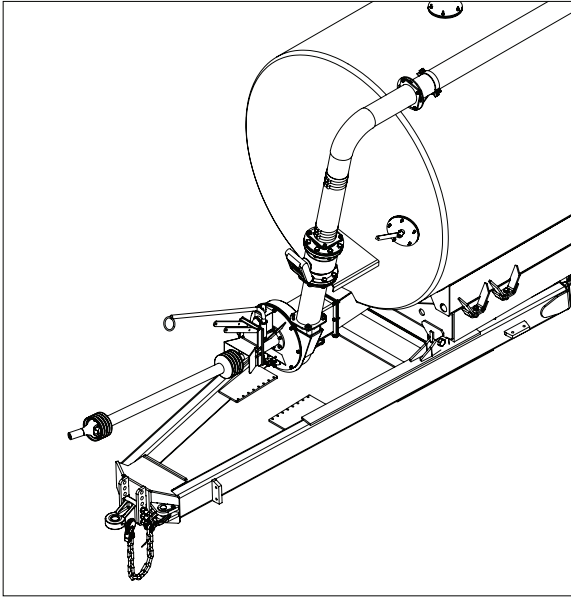

Item	Description	Quantity	Part Number
1	Bolt, Hex Head, 1/2"-13 X 1 1/2" GR5	4	1250
2	Transition Tube, Pump to Flow Meter	1	102013
3	Flange Nut, 1/2"-13 GR5	4	2539
4	Flange Nut, 3/4"-10 GR5	16	2086
5	Bolt, Hex Head, 3/4"-10 X 3" GR5	4	1315
6	Gasket, 11" OD X 6 1/2" ID	2	835506
7	Flow Meter	1	65256
8	Bolt, Hex Head, 3/4"-10 X 2 1/2" GR5	12	1313
9	Coupler, 8-Bolt to 4-Bolt	1	80738
10	Flange Nut, 1/2"-13	8	2084
11	Bolt, Hex Head, 1/2"-13 X 1 1/4" GR5	8	1249
12	Fitting, Hose Barb, 6"	1	65186
13	Hose Clamp, 144-166mm	4	16009
14	Hose, Layflat, 6" X 21 7/16", Brick Red	1	14454

SLURRY PUMP

Rite Rate Flow Control (Optional)

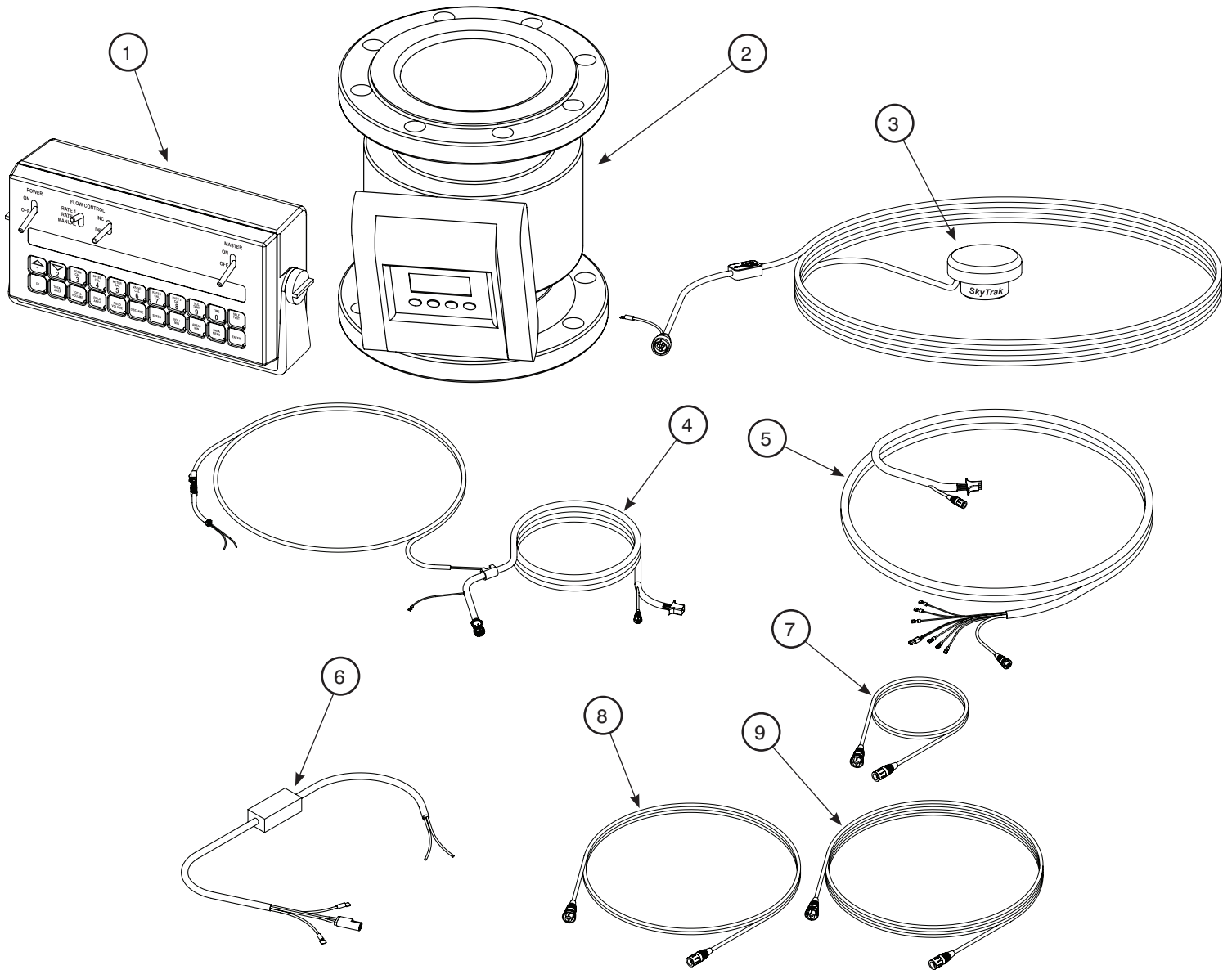

Item	Description	Quantity	Part Number
1	Raven SCS660 NVM Programmable Flow Controller	1	65255
2	Krohne Optiflux 4100C Electromagnetic Flow Sensor with Signal Converter	1	65256
3	SkyTrak GPS Velocity Sensor	1	863105
4	Raven SCS660 Console Cable	1	60680
5	Raven Flow Control Cable	1	65225
6	Raven 660 PWM Boost Box	1	65986
7	Raven Flow Meter Extension Cable, 6' (1.83m) (Standard)	1	863097
8	Raven Flow Meter Extension Cable, 12' (3.66m) (Optional)*	1	863098
9	Raven Flow Meter Extension Cable, 24' (7.32m) (Optional)*	1	863099

* Available for use with rear mounted pumps.

The logo for BALZER, featuring the word in a bold, italicized, sans-serif font with a white outline and a grey drop shadow. The logo is positioned on a green diagonal band that runs from the top left towards the bottom right.

BALZER

Decals

Decals

Item	Type	Description	Location	Quantity	Part Number
1	Danger	Confined Space	Tank - Front Left	1	72725
2	Warning	Operational Information	Tank - Front Left	1	20277
3	Informational	Operational Information	Tank - Front Left	1	71702
4	Informational	Full	Tank - Front Right	1	11039
5	Informational	Half Full	Tank - Front Right	1	11630
6	Informational	Empty	Tank - Front Right	1	11038
7	Maintenance	Steering System	Frame - Between Axles	4	37601
8	Maintenance	Wheels	Frame - Right Rear	1	700001
9	Danger	Lethal Gases	Tank - Left/Right Rear	2	40076
10	Danger	Injector	Frame - Left/Right Rear	2	60306
11	Informational	Serial Number	Tank - Left Front	1	12484
12	Informational	Oil Requirement	Slurry Pump - Oil Reservoir	1	71976
13	Informational	Operational Information	Slurry Pump - PTO Shield	1	14256
14	Danger	Moving Parts Hazard	Slurry Pump - PTO Shield	1	21730
15	Danger	PTO Hazard	Shield - PTO Shaft	1	383333
16	Warning	Operational Information	Jack Stand	1	860006
17	Warning	Gate Under Pressure	Gate Valve Handle	2	15694
18	Informational	Injector Connections	Frame - Rear	1	700005

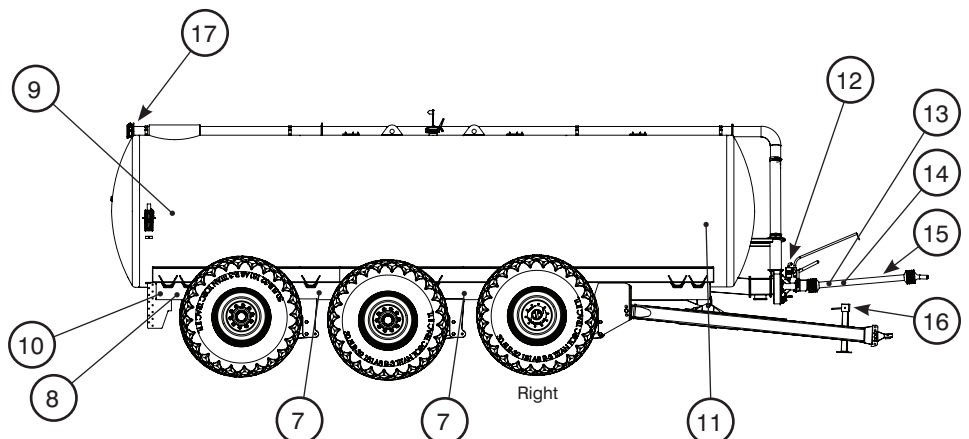
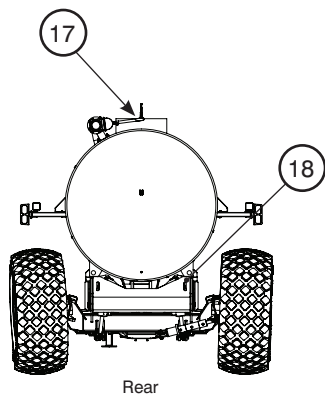
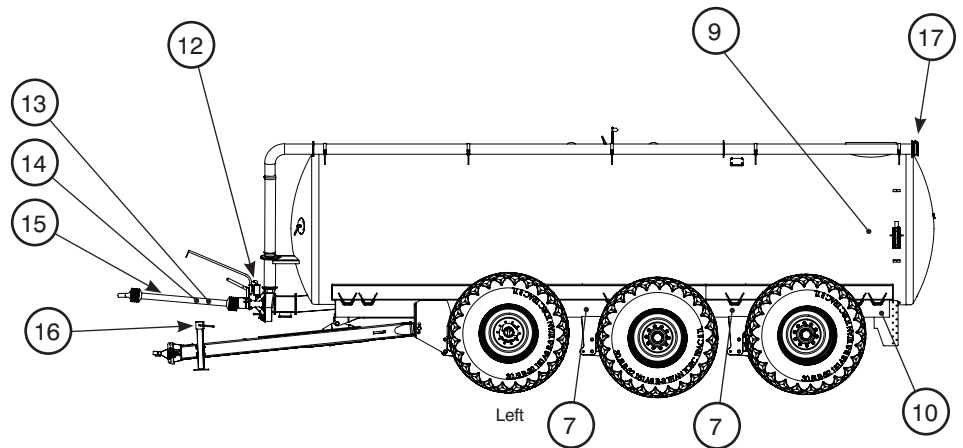
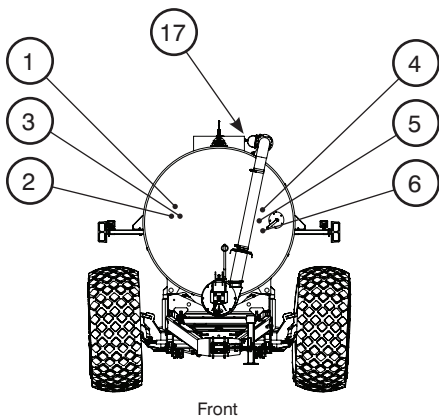

The logo for BALZER is rendered in a bold, italicized, sans-serif font. The letters are black with a white outline and a slight drop shadow, giving it a three-dimensional appearance. It is positioned at the top of the page, partially overlapping a green and white diagonal graphic element.

Notes

Date

Notes

Date

Notes



Magnum Slurry Tanks (Tridem)

Parts Manual
PM-MST-2

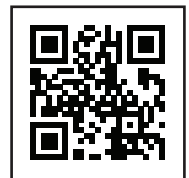

Balzer Incorporated reserves the right to make changes to their product and/or this manual to improve reliability, function, design, or safety without further notice. Balzer Incorporated is under no obligation, implied or otherwise, to upgrade, modify, or otherwise make changes to product manufactured prior to any design change.

Balzer Incorporated does not assume any liability arising out of the application or use of any product and neither does it convey any license under its patent rights. Balzer Incorporated does not assume any liability arising out of the use of their product for applications outside those for which it is expressly designed for.

© 2015 Balzer Inc. All Rights Reserved