

UM-EVT-1

November 4, 2014  
ECR: 101408R

# BALZER



## ELIMINATOR VACUUM TANKS (TANDEM) USER MANUAL

Serial Number: \_\_\_\_\_

Date of Purchase: \_\_\_\_\_

Purchased From: \_\_\_\_\_

Dealer's Address: \_\_\_\_\_

Dealer's Telephone: \_\_\_\_\_

# INDEX

<b>Company Statements . . . . .</b>	<b>1</b>	<b>Maintenance . . . . .</b>	<b>27</b>
Accuracy Statement . . . . .	1	Daily and Before Start of Season . . . . .	28
To the Purchaser . . . . .	1	Every 40 Hours . . . . .	30
Warranty Manufacture . . . . .	1	End of Season/Prepare for Storage . . . . .	30
Certificate of General Equipment Warranty . . . . .	1	Steering System Lubrication . . . . .	30
Liability for Delays . . . . .	2	Hub Lubrication . . . . .	31
Contact Information . . . . .	2	Hitch Lubrication . . . . .	31
Warranty Registration . . . . .	3	PTO Shaft Lubrication . . . . .	32
<b>Safety . . . . .</b>	<b>5</b>	Suspension Height Adjustment . . . . .	33
Mandatory Shut Down Procedure . . . . .	6	Steering Axle Toe Adjustment . . . . .	34
Additional Safety Reminders . . . . .	7	Brake System . . . . .	35
Personal Safety . . . . .	7	Adding Brake Fluid . . . . .	35
Towing Safety . . . . .	7	Bleeding the Brake System . . . . .	36
Operation Safety . . . . .	7	Vacuum Pump . . . . .	37
Hydraulic System Safety . . . . .	8	Before Start of Season . . . . .	37
PTO Operation Safety . . . . .	9	Daily Maintenance Checks . . . . .	38
Safety Signs and Decals . . . . .	10	Every 40 Hours of Use . . . . .	38
<b>Technical Data . . . . .</b>	<b>11</b>	End of Season/Preparing for Storage . . . . .	39
Specifications . . . . .	12	Vacuum Pump Automatic Oiler Adjustment . . . . .	39
Dimensions . . . . .	13	<b>Troubleshooting . . . . .</b>	<b>41</b>
Vacuum Pump . . . . .	14	Steering Not Working Correctly . . . . .	42
<b>Operation . . . . .</b>	<b>15</b>	Backing Up and Steering Not Locked Straight . . . . .	42
Pre-Operation Checks . . . . .	16	Hydraulic Controls Not Working Properly . . . . .	42
Hydraulic Hose Color Markings . . . . .	16	Brakes Not Working Properly . . . . .	42
Attaching to Tractor . . . . .	16	PTO Not Working . . . . .	42
Initial Start Up . . . . .	17	Vacuum Pump Not Working . . . . .	42
Tank Loading Procedure . . . . .	17	Slurry Pump Not Working . . . . .	43
PTO Drive System . . . . .	18	Rite Rate Flow System . . . . .	43
Hydraulic Drive System . . . . .	18	Rite Rate System Programming . . . . .	44
Jack Storage . . . . .	18	Rite Rate Console Cable Preparation . . . . .	45
Independent Cross Axle Steering System . . . . .	19	Rite Rate Wiring Installation . . . . .	46
Suspension Hydraulics . . . . .	20		
Suspension Limits . . . . .	22		
Braking System . . . . .	22		
Brake Operations . . . . .	22		
Brake Fluid Level Check . . . . .	22		
Vacuum Pump . . . . .	22		
Boom Control System . . . . .	22		
Boom Operations . . . . .	23		
Rite Rate Flow System . . . . .	24		
Rite Rate Flow System Field Operation . . . . .	25		



## Accuracy

Balzer Incorporated is dedicated to providing the most reliable and durable agricultural related products available. We have made every attempt to provide the most accurate and readily understandable information on our equipment. Due to our continuing efforts to produce the best products available, updates and improvements to our equipment may precede updates to this and other manuals. Therefore, the contents of this manual are based on the information in effect at the time of publication and are subject to change without notice.

It is the policy of Balzer Incorporated to constantly improve its products whenever it is practical to do so. Therefore, Balzer Incorporated reserves the right to redesign or change its equipment or component parts thereof without incurring the obligation to install or furnish such changes on equipment manufactured prior to date of redesign or change.

## To the Purchaser



This is the safety alert symbol. It is used to alert the operator to an instruction concerning the personal safety and risk factor of this equipment. Always observe and heed these very important instructions to promote a safe operation with good preventive maintenance habits.

This Balzer product is designed and manufactured to provide years of dependable service when used for the purpose for which it is intended, and when properly maintained.

**NEVER OPERATE THIS EQUIPMENT AT SPEEDS OVER 20 MPH.**

**NEVER OPERATE THIS EQUIPMENT UNTIL USER FULLY UNDERSTANDS THE COMPLETE CONTENTS OF THIS MANUAL. FOR OWNERS WHO DO NOT OPERATE THIS EQUIPMENT, IT IS THE OWNER'S RESPONSIBILITY TO ENSURE ALL USERS ARE PROPERLY INSTRUCTED AND FULLY AWARE OF THIS MANUAL'S CONTENTS.**

This is important in the safe handling of this equipment and promoting an efficient operation. If there are any questions about areas in this manual, it is important to contact your dealer for clarification.

This machine is warranted as stated below. Registration of this equipment is to be completed online as soon as possible. This will provide a ready reference to help you in securing warranty and in answering questions that you may have at some later date.

Operating instructions and parts manuals are shipped with this machine. If parts of these manuals are missing or become unreadable, contact your dealer for a replacement manual.

The serial number and identification tag is located to the front of the frame. Please refer to these numbers when parts or warranty communication is necessary.

## Warranty Manufacture

The Dealer or Distributor understands and agrees the Manufacturer extends only the following Warranty to customers. In the event a Dealer or Distributor extends any additional warranty (such as by enlarging the scope or period of warranty or undertaking a warranty of merchantability or fitness for any particular purpose) or any other obligation whatsoever, the Dealer or Distributor shall: (1) be solely responsible therefore; (2) have no recourse against the Manufacturer thereof; and (3) defend, indemnify, and hold the Manufacturer harmless against any claim or cause of action whatsoever arising out of, or occasioned by, the Dealer's or Distributor's extension of said additional warranty or obligation.

## Certificate of General Equipment Warranty

Balzer Inc. warrants new Products sold by it to be free from defects in material and/or workmanship for a period of one (1) year after the date of delivery to the first user and is subject to the following conditions:

1. Balzer Inc.'s obligation and liability under this Warranty is expressly limited to repairing or replacing at Balzer Inc.'s option any parts which, upon inspection by Balzer Inc., to have been defective in material or workmanship. Such parts shall be provided at no cost to the user and shall be delivered to the business establishment of the authorized Balzer Inc. dealer or distributor of the Product during that dealer's or distributor's regular working hours.
2. This Warranty shall NOT apply to component parts or accessories of Products not manufactured by Balzer Inc. and which carry the warranty of the manufacturer thereof, or to normal maintenance (such as tune-up) or normal maintenance parts (such as oil filters).
3. Replacement or repair parts installed in this Product covered by this Warranty are warranted only for the remainder of this Warranty if such parts replaced were original components of said Product.

## Certificate of General Equipment Warranty (Continued)

BALZER INC. MAKES NO OTHER WARRANTY, EXPRESS OR IMPLIED, AND MAKES NO WARRANTY OF MERCHANTABILITY OR FITNESS FOR ANY PARTICULAR PURPOSE.

Balzer Inc.'s obligation under this Warranty shall not include any transportation charges, cost of installation, duty taxes, or any other charges whatsoever, or any liability for direct, indirect, incidental, or consequential damage or delay. If requested by Balzer Inc., products or parts for which a warranty claim is made are to be returned transportation prepaid to Balzer Inc. This Warranty shall become void under, but not limited to, any of the following conditions: any improper use, including operation after discovery of defective or worn parts, operation beyond rated capacity, or operation for a use other than this Product's intended design; substitution of parts not approved by Balzer Inc.; or modifications or repairs by others that are done in a manner as determined by the judgment of Balzer Inc. to have adversely affected the material or workmanship of this Product.

NO EMPLOYEE OR REPRESENTATIVE IS AUTHORIZED TO CHANGE THIS WARRANTY IN ANY WAY OR GRANT ANY OTHER WARRANTY UNLESS SUCH CHANGE IS MADE IN WRITING AND SIGNED BY AN OFFICER OF BALZER INC. AT ITS HOME OFFICE.

## Liability for Delays

No liability shall attach to Manufacturer direct or indirect for incidental or consequential damages or expenses due to loss, damage, detention of, or delay in delivery of Products resulting from acts or delays beyond its control.

## Contact Information

Telephone Numbers

Toll-Free: (800) 795-8551  
(800) 727-3133  
Outside North America: (507) 427-3133  
Fax: (507) 427-3640

Mailing/Shipping

Balzer Inc.  
County Road 27 East  
PO Box 458  
Mountain Lake, MN 56159

Website

[www.balzerinc.com](http://www.balzerinc.com)

## Warranty Registration

As of June 1, 2014, all warranty registration must be completed online to be valid. Registering online is fast and easy.

If you are viewing this manual on a device connected to the Internet, click here:

**REGISTER NOW!**

Go to the Balzer website at [www.balzerinc.com](http://www.balzerinc.com) and click on "Parts and Service".

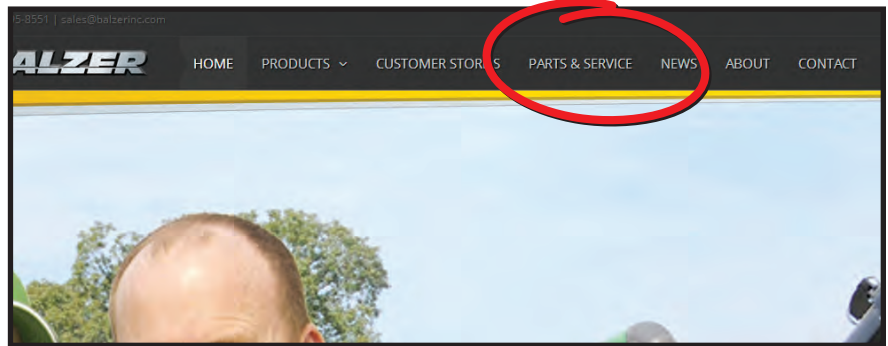

Then, on the right side of the website, click on the "Register Now" button under "Warranty Registration".

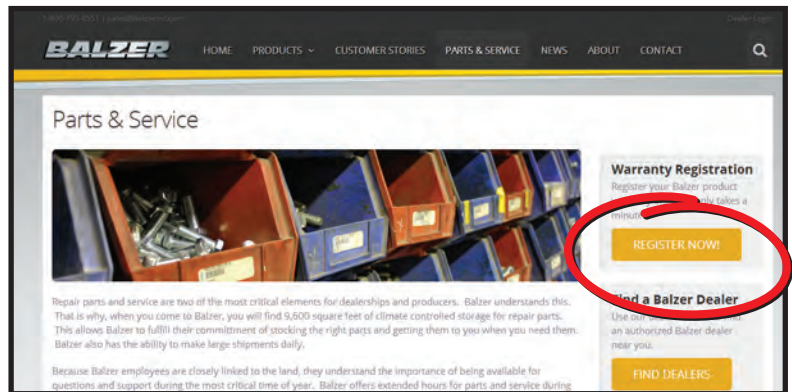

Complete the online form and click "Submit".

Balzer Inc. is committed to our customers and their privacy. Balzer Inc. will only use the information you give us to provide prompt warranty claims and services to you. Balzer Inc. uses appropriate safeguards which reasonably and appropriately protect the information that Balzer Inc. creates, receives, maintains, or transmits on behalf of our customers. Any personally identifiable information obtained will not be sold, rented, shared, or made available to third parties.





**BALZER**

# Safety

The following Safety Alert Symbols mean **ATTENTION! BECOME ALERT! YOUR SAFETY IS INVOLVED!** They stress an attitude of **“HEADS UP FOR SAFETY”** and can be found throughout this manual and on the equipment itself.

**BEFORE YOU ATTEMPT TO OPERATE, MAINTAIN, OR SERVICE THIS EQUIPMENT, READ AND STUDY THE FOLLOWING SAFETY INFORMATION. IN ADDITION, MAKE SURE THAT EVERY INDIVIDUAL WHO OPERATES, WORKS WITH, OR OTHERWISE USES THIS EQUIPMENT IS FAMILIAR WITH THESE SAFETY PRECAUTIONS.**

Our company **ALWAYS** takes operator safety into consideration when designing its machinery, guards, and exposed moving parts for operator protection. However, some areas can **NOT** be guarded or shielded in order to assure proper operation. In addition to this manual, decals on the machine warn of further danger and should be read and observed closely.

**READ** and **FOLLOW** the instructions on all decals.

**REMEMBER** it is the owner's responsibility for communicating all information on the safe use and proper maintenance of this machine! This includes providing understandable interpretation of these instructions for operators who are not fluent in reading or understanding English.

	<b>DANGER</b>	<b>DANGER</b> indicates an imminently hazardous situation which if not avoided will result in serious injury or death or irreparable damage to the machine.
--	---------------	---

	<b>WARNING</b>	<b>WARNING</b> indicates a potentially hazardous situation which if not avoided may result in serious injury or death or moderate to severe damage to the machine.
--	----------------	--

	<b>CAUTION</b>	<b>CAUTION</b> indicates a potentially hazardous situation which if not avoided may result in minor to moderate injury or minor to moderate damage to the machine.
--	----------------	--

## Mandatory Safety Shutdown Procedure

**BEFORE** cleaning, adjusting, lubricating, or servicing this equipment:

1. Remove the ignition key from the power unit engine.
2. Make sure ALL movement throughout this equipment has ceased! **ONLY** when you have taken these precautions can you be sure it is safe to proceed. Failure to follow the above procedure may lead to serious injury or death.
3. Properly attach the jack to this equipment and raise up to transfer weight to the jack.
4. Keep the hitch pin attached to help prevent this equipment from moving.
5. Disconnect the PTO shaft from the power unit.

## Additional Safety Reminders

**USER/OPERATOR SAFETY PRACTICES** are included in this manual and are intended to promote SAFE OPERATION of this equipment. These guidelines do not preclude the use of good judgment, care, and common sense as may be indicated by the particular job site work conditions.

It is essential that all operators be physically and mentally free of any mind altering drugs and chemicals and thoroughly trained in the safe operation of this equipment. Such training should be presented completely to all new operators and **NOT** condensed for those claiming previous experience.

**FOR ILLUSTRATION PURPOSES ONLY** some photographs and images in this manual may show doors, guards, and shields open or removed. **BE SURE** all doors, guards, and shields are in their proper operating positions **BEFORE** operating this equipment. **NEVER** operate this equipment with any guards or shields damaged or not in place. **REPLACE** any damaged or missing guards and shields.

### **KEEP HANDS AND FEET AWAY FROM ALL MOVING PARTS!**

The operator **MUST** know the capabilities and work applications for this equipment and operate it at speeds slow enough to ensure complete control at all times. When working on uneven ground or near the edge of roadbeds there is no substitute for good judgment and only operators with sufficient experience should attempt such work.

**NEVER** assume everyone is as safety conscious as you are.

## Personal Safety

**NEVER** allow minors and/or any unqualified personnel to operate or be near this equipment unless properly supervised.

**NEVER** allow anyone to ride on this equipment at any time.

**NEVER** leave this equipment running unattended.

**NEVER** wear loose or torn clothing while working around moving parts.

**NEVER** step on the PTO drive shaft at any time.

**ALWAYS** wear appropriate personal safety equipment and gear as called for by the job or working conditions.

**ALWAYS** be aware of pinch point areas on this equipment.

**ALWAYS** keep hands, feet, hair, and clothing away from moving parts.

**ALWAYS** stop and disengage the PTO and shut off the tractor before doing any adjusting or servicing to this equipment.

## Towing Safety

### **THE MAXIMUM SPEED FOR TOWING THIS EQUIPMENT IS 20 MPH.**

Observe the recommended maximum road speed limit, local speed limit, or maximum recommended towing speed whichever is the lesser speed.

### **ALWAYS MOVE THIS EQUIPMENT WITH A FARM TRACTOR ONLY.**

Always engage power steering (on equipment with steering capabilities) before turning with a load.

**DO NOT DISENGAGE** power steering (on equipment with steering capabilities) before the turning process is completed.

Tractor must be heavy and powerful enough and have adequate braking power for the towed load.

**STOPPING DISTANCE** increases with speed and weight of towed loads and on slopes. Towed loads, with or without brakes, which are too heavy for the tractor or are towed too fast can cause loss of control. Consider the total weight of all equipment and the load.

Use additional caution when towing loads under adverse surface conditions (ice, mud, loose gravel, etc.), turning, or slopes.

**DO NOT ATTACH** safety chain to any point higher than the drawbar.

## Operation Safety

Before each tow check the electrical connection, tail lights, brake lights, and turn signals. Damaged lights or improper electrical connection between the tractor and this equipment will result in inoperable lights and/or inoperable electric brakes.

Do not operate on public roads after dark without warning lights.

## Operational Safety (Continued)

Be sure the rear of this equipment has a visible and clean "Slow Moving Vehicle" emblem properly displayed. If towing at speeds less than 20 MPH on any public roadway at night, proper warning and running lights are necessary as required by state law!

**DO NOT** pull this equipment without having safety chains (not supplied) securing this equipment to the tractor.

Refer to local transportation laws for regulation on safety chain use. **MAXIMUM TOWING SPEED IS 20 MPH.**

The tractor must be of sufficient size to maintain vehicle stability when this equipment is fully loaded.

ALWAYS use a hitch pin which has a safety clip pin!

If this equipment includes a braking system, check oil level and braking capacity with a full load before operating or moving this equipment.

Check the wheel lug bolts and lug nuts daily and tighten as needed.

Replace any parts showing signs of excessive wear, cracking, or likelihood of failure with original equipment service parts.

Be familiar with all valves, doors, gates, and hydraulic controls.

**BEFORE USE** make sure this equipment does **NOT** have any foreign objects or materials which can cause equipment damage or personal injury.

**NEVER ENTER THIS EQUIPMENT UNLESS ABSOLUTELY NECESSARY!** If entry is necessary, take proper safety precautions to include but not limited to:

- Additional person on site and on the outside near the point of entry
- Safety harness and ropes where appropriate or required by law
- Proper life support system where appropriate or required by law
- Mechanical and electrical power disconnected
- Contacting your Balzer dealer for more information before entering

Check that the PTO slides freely, is not damaged, and is properly secured to the tractor and this equipment. Make sure there is approximately 1/3 overlap of engagement. (Refer to Figure 8: Drawbar Adjustment on Page 16.)

Be alert and avoid loose, soft, or icy surface conditions which could cause tipping or loss of control.

When possible, travel straight up or down a slope. Avoid traveling along side of hills, ditches, or other sloped surfaces.

Slow down prior to going down any steep grade.

Always check the job site for hazardous terrain, obstructions, or bystanders.

Never take tractor out of gear when going up or down a hill.

Do not exceed the maximum weight carrying capacity of the equipment or the tractor manufacturer's maximum towing capacity, whichever is the lesser weight. If you have any questions, contact your Balzer dealer.

Never use a tractor that is not recommended for this equipment's application.

When agitating a pit, always make sure there is adequate ventilation in any confined area.

Do not stand in front, behind, or along side this equipment when it is in operation or in motion.

When parking this equipment, securely block the wheels before unhitching from the tractor.

## Hydraulic System Safety

**DO NOT** smoke when working on hydraulic systems.

**NEVER** use your hand to search for hydraulic fluid leaks. Escaping fluid under pressure can be invisible and can penetrate the skin causing serious injury and other health hazards. Escaping fluid can also be extremely hot causing severe burns.

Use a scrap piece of cardboard to check for leaks.

**IF ANY FLUID IS INJECTED INTO YOUR SKIN, SEEK MEDICAL ATTENTION IMMEDIATELY!** Notify medical staff that there is an injection injury with hydraulic fluid. Injected fluid must be surgically removed by a doctor familiar with this type of injury or gangrene may result.

**DO NOT** attempt to loosen or disconnect any lines, hoses, or fittings without first relieving hydraulic circuit pressure. Be careful not to touch any hydraulic components recently in operation because they can be extremely hot.

**SAFETY****Hydraulic System Safety (Continued)**

**ALWAYS** replace hydraulic components with manufacturer recommended replacement parts. Improperly rated components may result in system failure and/or injuries.

Contact your local Balzer dealer to order replacement parts.

**PTO Operation Safety**

Do not wear loose fitting clothing or have long, free-hanging hair when operating the PTO (Power Take Off) or near ANY rotating equipment.

Never exceed the recommended operating speed (PTO and drive) for the particular equipment in use.

When operating stationary PTO driven equipment, always apply the tractor's parking brake lock and block the rear wheels front and back.

To avoid injury, do not clean, adjust, unplug, or service PTO driven equipment when the tractor engine is running.

When finished with the operation of PTO driven equipment, shift the PTO control to neutral, shut off the engine, remove the key, and wait until the PTO stops before exiting the tractor.

Implement input drivelines, clutches, and freewheels are designed for specific machine types and power requirements. They must not be replaced by any shaft other than that recommended by the implement manufacturer. Note the Operating Instructions from both the tractor manufacturer and the implement manufacturer. Ensure the implement driveline is securely connected at both ends.

Only use a completely guarded drive system (Figure 1). PTO drive systems with complete guarding include: the tractor master shield, the implement driveline guard (end cones, telescoping section sleeves, guard chain), and the implement safety shield. These safety devices must be installed at all times.

	<h1 style="margin: 0;">WARNING</h1>	<p><b>PTO mounted drive shafts must only be used for their intended purpose.</b></p>
--	-------------------------------------	--

Figure 1

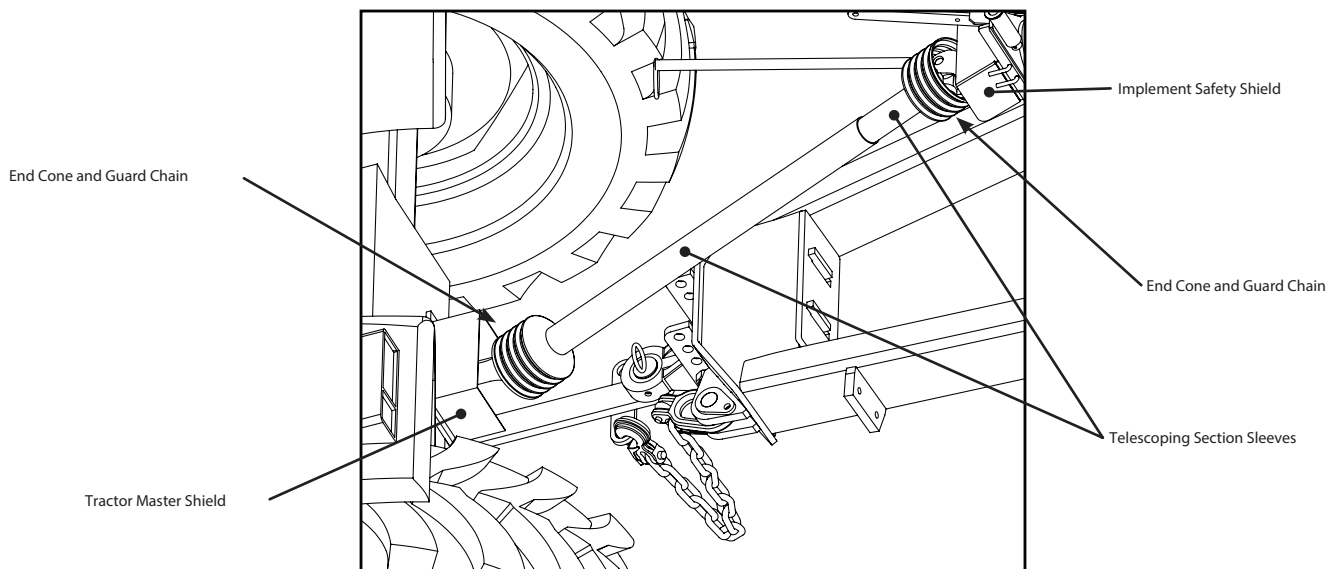

	<h1 style="margin: 0;">DANGER</h1>	<p><b>DO NOT operate PTO without all guards in place and in safe operating condition.</b></p>
---	------------------------------------	---

## PTO Operation Safety (Continued)

If any component of the guarding system has been removed for any reason, it must be repaired or replaced prior to operation of the machine.

### Safety Signs and Decals

Safety signs or decals provide very important information and instructions designed to alert you to dangers and hazards which can be present during operation of this equipment. These safety signs and decals **MUST** be read, understood, and followed to be effective.

#### Replacement of Safety Signs and Decals

Safety signs and decals must be kept clean and readable. If they become unreadable for any reason, they must be replaced with an identical replacement sign or decal. Safety signs and decals must also be replaced if damaged when repairing this equipment or if not included with the replacement part.

#### Application of Safety Decals

Surface preparation is very important for the safety decals to properly adhere. Grease, oil, and dirt must be removed and the surface must be smooth and dry. After wiping the surface clean, use an ammonia-free window cleaner to provide the best surface for decal adherence.

Most decals have a split backing which is meant to be removed from the split outward. To apply decals, follow these steps:

1. Position the decal in the proper location and hold firmly over the largest portion of the backing.
2. Use one hand to hold the decal in position. With the other hand, carefully roll the loose end over and peel the backing outward. When the backing is removed as shown in Figure 3 and with even and gradual pulling, the decal will roll onto the surface smooth and wrinkle free,
3. With the smallest portion of the decal attached, the repeat Step 2 for the other half of the decal.

When the decal has been attached in place, use a cloth or soft paper towel to burnish the decal onto the cleaned surface. Work gently from the middle outwards to avoid creating any wrinkles and to remove any air bubbles.

Figure 2



Figure 3

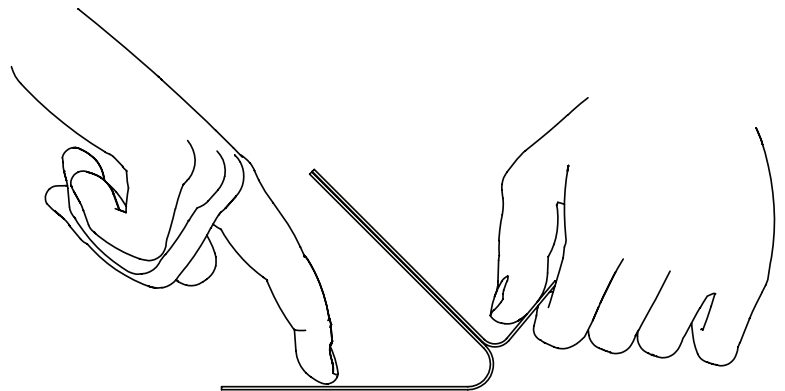



**BALZER**

# Technical Data

Figure 4

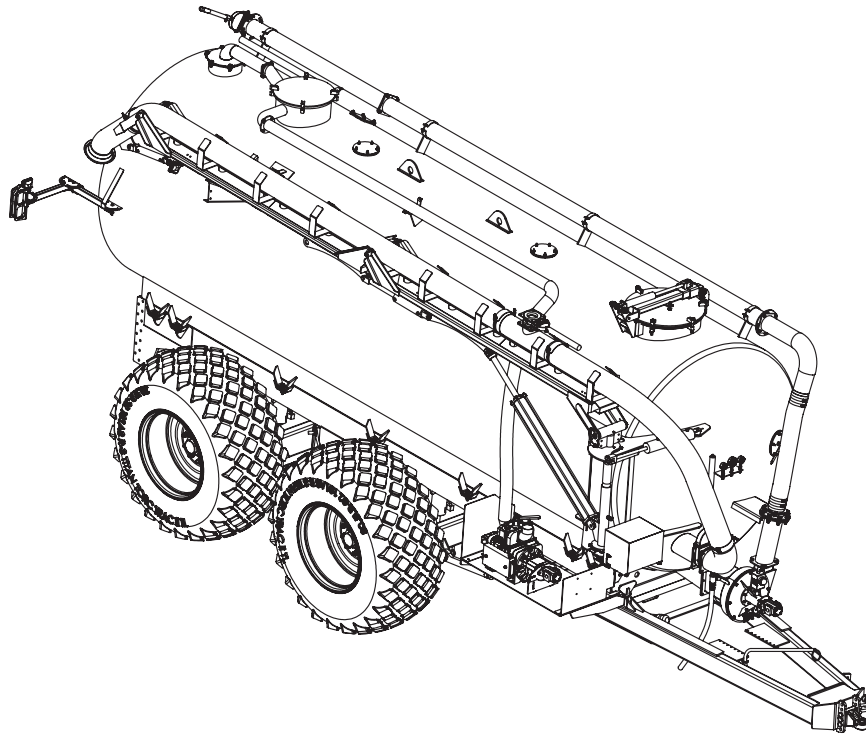

**Dimensions**

See "Dimensions" on Page 13

**Tire Pressure**

28L X 26 R3	26 PSI (180 kPa)
28LR26 R3	54 PSI (372 kPa)
30.5 X 32 R1	33 PSI (228 kPa)
30.5 X 32 R3	33 PSI (228 kPa)
30.5LR32 R1	52 PSI (359 kPa)
30.5LR32 R3	52 PSI (359 kPa)
850/50 30.5	37 PSI (256 kPa)
900/60 32 R1*	35 PSI (241 kPa)

**Lug Nuts**

Torque to 450 FT/LBS

**Brake Type**

Disc

**Hydraulic Operating Pressure**

Up to 3000 PSI  
(20.68 MPa)

**Electrical System**

12 VDC

**Electrical Connection**

7-Way Receptacle

**Maximum Tow Speed**

20 MPH  
(32 KPH)

**TRACTOR REQUIREMENTS**

PTO Horsepower Maximum	248 hp
PTO Speed	1000 RPM
Drawbar Max. Vertical Load	4,100 lbs (CAT-3) (1,860 kgs)
Drawbar Clevis Pin Diameter	2" (5 cm)
PTO to Drawbar Distance	16" to 20" (40 cm to 50 cm)
Drawbar to Ground Height Distance	15" to 22" (38 cm to 56 cm)
Tractor Hydraulic Flow PTO	10 GPM (37.8 LPM)
Hydraulic Motor	30 GPM (113.6 LPM)
Tractor Hydraulic Pressure	Up to 3,000 PSI (20.68 MPa)

\* Not available for Narrow tanks



## Dimensions

Figure 5

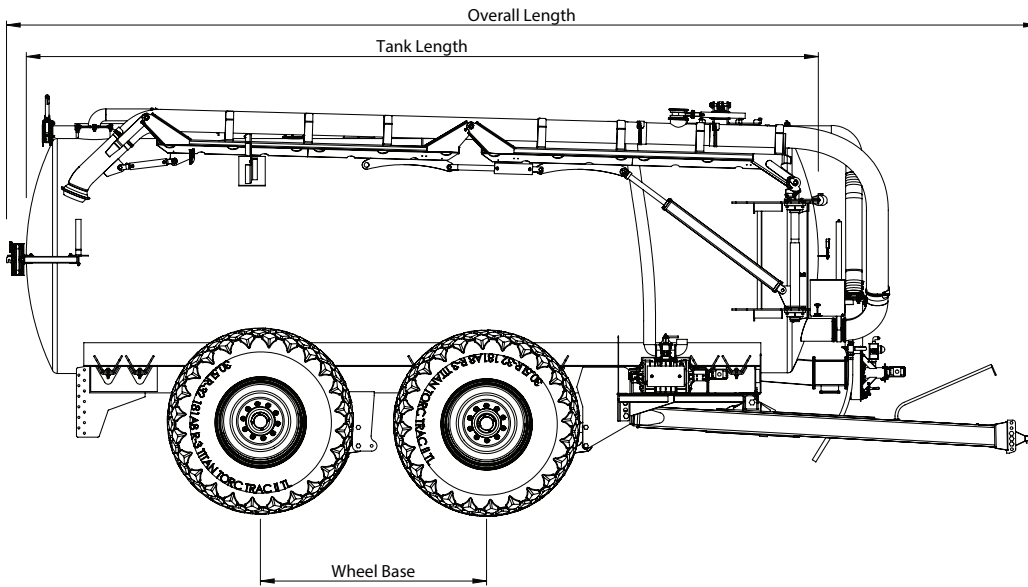
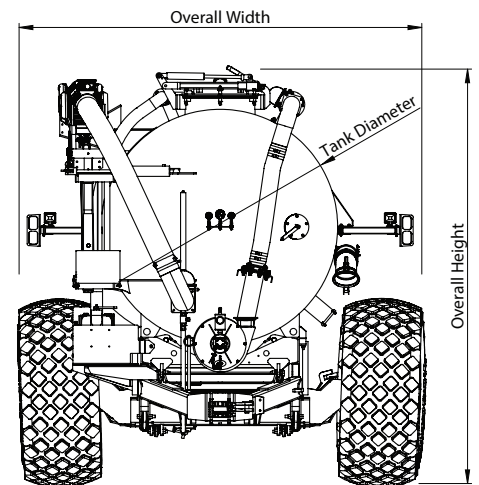
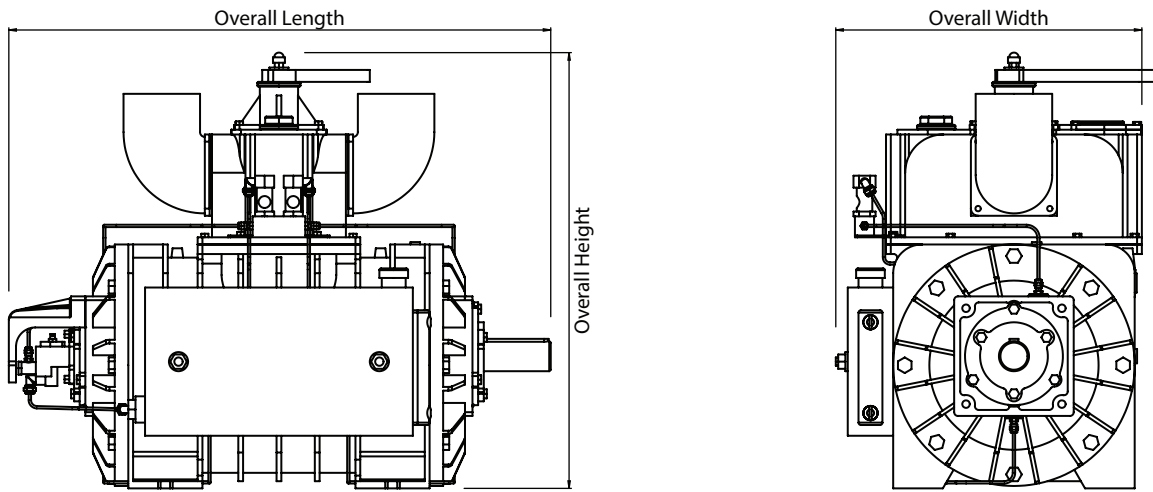

Figure 6



Eliminator Vacuum Tank				
Specification	6800	6500N	7650	7350N
Overall Length	390 1/2" (991.9 cm)	390 1/2" (991.9 cm)	390 1/2" (991.9 cm)	390 1/2" (991.9 cm)
Overall Width	152 1/2" (387.4 cm)	132 1/2" (336.5 cm)	152 1/2" (387.4 cm)	132 1/2" (336.5 cm)
Overall Height	152" (386 cm)	152" (386 cm)	157" (398.8 cm)	157" (398.8 cm)
Tank Length	300" (762 cm)	300" (762 cm)	300" (762 cm)	300" (762 cm)
Tank Diameter	84" (213.4 cm)	84" (213.4 cm)	89" (226.1 cm)	89" (226.1 cm)
Wheel Base	86" (218.5 cm)	86" (218.5 cm)	86" (218.5 cm)	86" (218.5 cm)
Clearance	19" (48.25 cm)	19" (48.25 cm)	19" (48.25 cm)	19" (48.25 cm)
Capacity	6800 Gallons (25,740 Liters)	6500 Gallons (24,605 Liters)	7650 Gallons (28,960 Liters)	7350 Gallons (27,825 Liters)
Empty Weight	~23,850 lbs (~10,820 kgs)	~23,850 lbs (~10,820 kgs)	~24,000 lbs (10,885 kgs)	~24,000 lbs (10,885 kgs)

Figure 7



Dimensions	
Overall Length	28 <sup>5</sup> / <sub>16</sub> " (71.9 cm)
Overall Width	16" (40.6 cm)
Overall Height	22 <sup>3</sup> / <sub>4</sub> " (57.8 cm)
Port Diameter	4" (10.2 cm)
RPM Range	800-1000
Maximum Vacuum	27 inHg / 90%
Maximum Continuous Vacuum	18 inHg / 60%
Flow Rate at 60%	452 CFM (12,800 l/min)
Flow Rate at Free Air	500 CFM (14,200 l/min)
Maximum Pressure	30 PSI (206.8 kPa)
Horsepower	28 HP
Oil Tank Capacity	4.23 qt (4 l)



**BALZER**

# Operation

## Pre-Operation Checks

Make sure all safety shields are in place and properly secured.

Make sure all moving components are free of solid, hard, or frozen material or other obstructions.

Make sure the tractor drawbar matches the standards shown in the Drawbar Adjustment diagram (Figure 8).

Figure 8

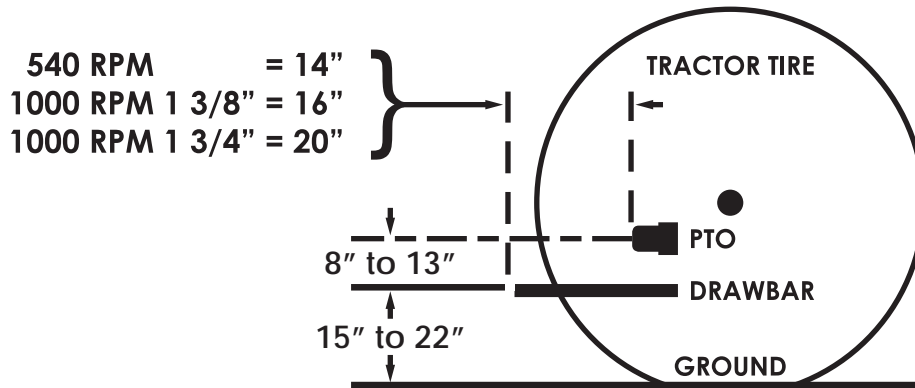

Suggested drawbar adjustments for PTO shaft size and speed.

	WARNING	Improper PTO Length may damage the unit
--	---------	---

## Hydraulic Hose Color Markings

Each hydraulic hose will have either one (1) color code stripe indicating it as a Return line or two (2) color code stripes indicating it is a Pressure line. The exception is for the Hydraulic Motor Zero Return line which has two stripes but only one of each color. The following color codes denote the operational purpose of the hydraulic hose lines.

**RED** - Brakes

**GREEN** - 3-Way Valve or T-Valve

**BLUE** - Hydraulic Motor

**YELLOW** - Steering System

**ORANGE** - Down Pressure

**BLUE/GREEN** - Hydraulic Motor Zero Return Line

	DANGER	If the unit is equipped with a Zero Return Hydraulic Line it must be connected to a Zero Return Hydraulic connection on the tractor otherwise <b>DAMAGE TO THE HYDRAULIC MOTOR WILL OCCUR!</b>
--	--------	--

## Attaching to Tractor

Attach the tractor's drawbar to the hitch using a properly sized hitch pin. The hitch pin should have a safety retainer to keep it from dislodging itself from the hitch.

Attach the safety chain to the drawbar of the tractor. Attaching the safety chain to a point higher than the drawbar can lead to a potential rollover causing serious injury or death (Figure 9).

	DANGER	Attaching the safety chain to any point higher than the drawbar can cause tractor to rollover should this machine become unhitched from the tractor. Tractor rollover can cause serious injury or death!
--	--------	--

**OPERATION****Attaching to the Tractor (Continued)**

Crank the trailer jack down to slowly place pressure on the drawbar. After the weight has been transferred to the tractor's drawbar and is no longer being supported by the jack, remove the jack and secure it in its storage location.

Check the tractor's Power Take Off (PTO) for any damage, that it slides freely, and is the proper size and connection for the PTO shaft on the tank.

Attach the PTO shaft to the tractor securely as required by its locking mechanism. The PTO should have approximately 1/3 overlap.

Attach the hydraulic lines making sure the connectors are clean and in good repair. Connect according to the hydraulic hose color and striping pattern listed in the Hydraulic Hose Color Markings section on the previous page.

Connect the 7-Way electrical connector.

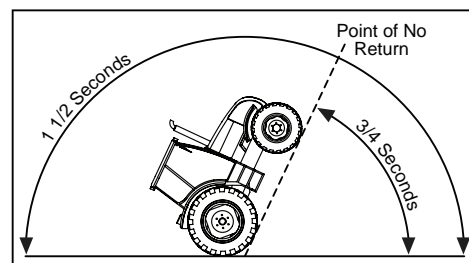
**Figure 9****Initial Start Up**

Never operate this machine if shields are missing, damaged, or improperly installed or if persons are in or on this machine or near any moving parts of this machine. Keep everyone away while operating this machine.

Do not leave the tractor seat.

Operate **ALL** hydraulic controls to become familiar with the function of each tractor lever and to visually see the machine is responding correctly. **NOTE: MAKE MENTAL AND/OR WRITTEN NOTES CONCERNING WHICH WAY TO MOVE THE LEVERS FOR THE DESIRED RESULTS.**

**ENGAGE THE PTO SLOWLY** with the tractor throttle at slow idle. Use maximum modulation on tractor PTO control.

Watch and listen to confirm the machine is operating properly. Run at fast idle for five (5) minutes, disengage the PTO, shut off the tractor engine, and remove the key from the ignition. Make all necessary adjustments before any further operation of this machine is attempted.

**CAUTION**

**To prevent premature driveline failure, tractor turning should be limited to approximately 10° when driveline is rotating.**

**Tank Loading Procedure**

Position the tank under the load stand or attach filling hose to the Self-Load Function.

Load the tank until full. The flag on top of the tank is attached to a float which will begin to rise when the tank is full. Over filling the tank may result in spillage of manure.

Lower the plow into the ground. If a Down Pressure Block is available, increase or decrease pressure to control the plow's force in the ground.

Engage the hydraulic motor or PTO, whichever the machine is equipped with, to drive the slurry pump.

Begin injecting manure into the ground.

**DANGER**

**DO NOT TURN the machine if the plow is in the ground. DAMAGE TO THE PLOW WILL OCCUR.**

To stop injecting manure into the ground, disengage the hydraulic motor or PTO driving the slurry pump.

Raise the plow.

## PTO Drive System

If this machine is equipped with a PTO shaft, it will have one of the following shafts (check which shaft is used):

- PTO Shaft, 1 3/8"-21 to 1 1/2" Round with 3/8" Keyway (Standard)
- PTO Shaft, 1 3/4"-20 to 1 1/2" Round with 3/8" Keyway
- PTO Shaft, CV 1 3/8"-21 to 1 1/2" Round with 3/8" Keyway
- PTO Shaft, CV 1 3/4"-20 to 1 1/2" Round with 3/8" Keyway

The PTO shaft will have the 1 1/2" Round with 3/8" Keyway attached to the implement side of the machine. This implement side has a shear bolt to protect the gear box and drive line of the tractor's PTO from overload (Figure 10). The PTO must be engaged slowly, use maximum modulation on the tractor. **DO NOT SLAM ENGAGE THE PTO.**

Figure 10

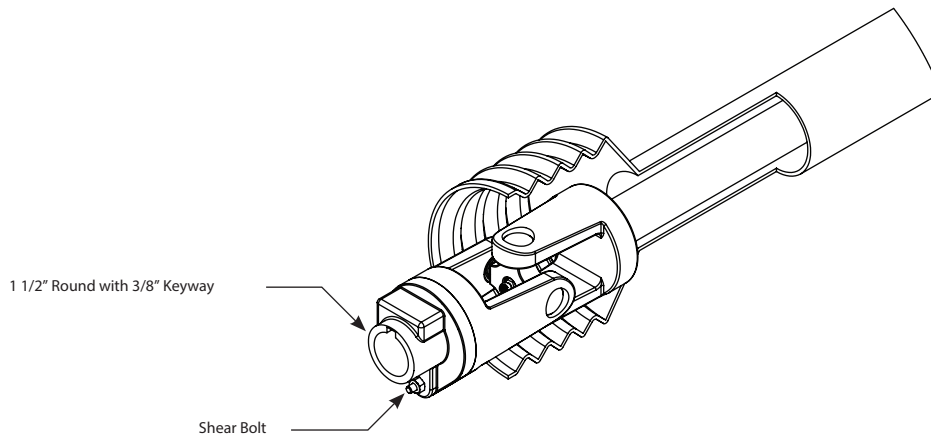

## WARNING

**DO NOT slam engage the PTO. Damage to the machine or the tractor may occur at any time during operation following a slam engagement of the PTO.**



## DANGER

**DO NOT OPERATE this machine without all PTO shields and guards in place and properly secured.**

The PTO shaft should not be extended any more than half the length of the telescoping member overlap.

## Hydraulic Drive System

If this machine is equipped with a hydraulic motor, it will have one of the following (check which motor is used):

- 3.94 CU IN Hydraulic Motor (Standard)
- 6.35 CU IN Hydraulic Motor

When engaging the hydraulic motor, do so slowly to avoid damage to the motor.

## Jack Storage

After the machine has been securely attached to the drawbar of the tractor and the jack is no longer supporting the weight of the tongue, finish raising the leg of the jack. Remove the two locking pins (Figure 11), move the jack to the storage location on the tongue, and re-insert the locking pins to secure the jack (Figure 12).

**OPERATION**

Figure 11

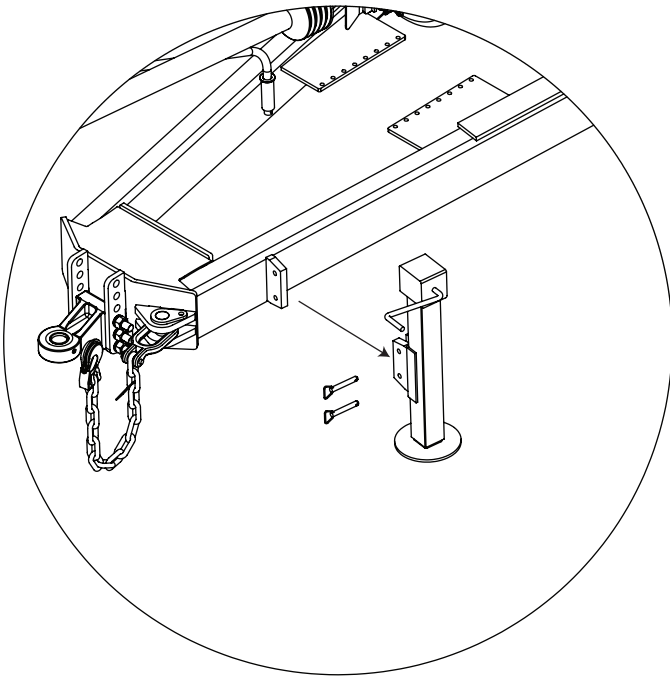

Remove pins and pull the jack off of the support tab.

Figure 12

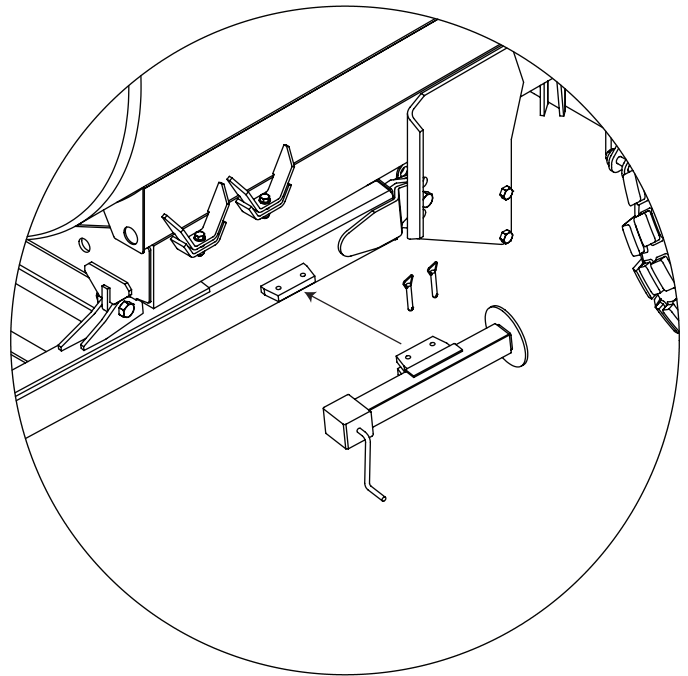

Slide jack onto storage tab and re-insert pins.

**WARNING**

**DO NOT** move or operate this machine with the jack in the support position. Failure to move the jack to the storage position may result in damage to the jack and/or this machine.

**WARNING**

**DO NOT** use the jack in the support position unless the tank is empty.

## Independent Cross Axle Steering System

The front axle on this machine is a straight (non-steering) axle and the rear axle is the steering axle. The steering on this axle is operated by two main components:

- a tie rod
- a hydraulic cylinder

The tie rod has two grease points which must be sufficiently greased at the start of every day's use. Check the kingpins for a grease point (Figure 13). The grease point for the kingpins may be connected to a grease line placing the grease points on the right side rear of the frame. If there is no grease point, the kingpin has a poly bushing which does not need greasing. These grease points must also be greased well after washing and at the end of the season when preparing the machine for storage.

The steering hydraulic cylinder is only used to bring the steering wheels inline with the straight axle for backing up.

Placing the tractor's hydraulic lever into the "Float Position" allows the machine to steer. As the steering wheel of the tractor is turned, the wheels to trail the tractor's direction due to ground pressure allowing maneuverability (Figure 14).

Moving the tractor's hydraulic lever to the "Pressure Position" will position the rod of the cylinder so that the steering wheels line up with those of the straight axle allowing the machine to be backed up with ease. Figure 15 shows the hydraulic connection schematic for the steering hydraulic cylinder.

Figure 13

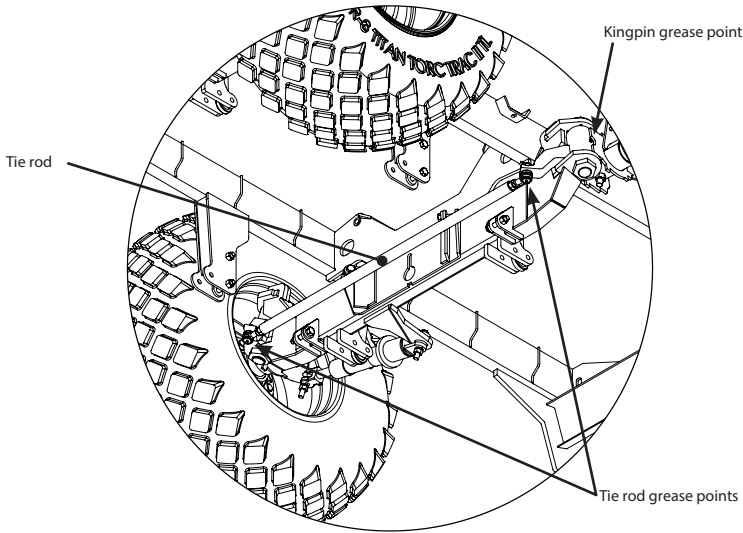

Figure 14

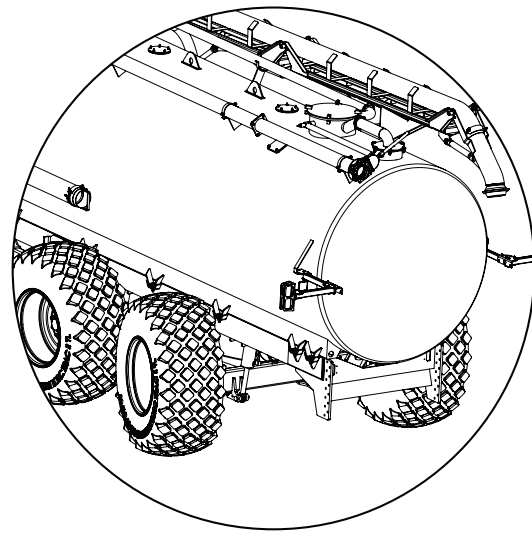
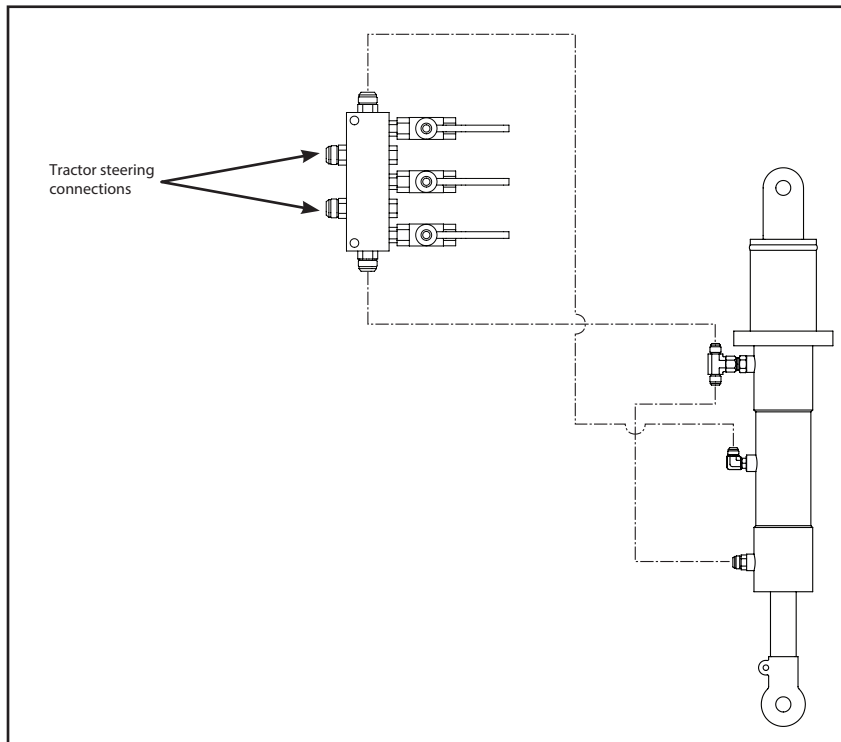

Figure 15



## Suspension Hydraulics

Each axle has two (2) hydraulic cylinders (Figure 16) to transfer the load from the frame to the axle. The axles are attached to the frame by four (4) parallel links, two (2) on each side of each axle, which stabilize the axles and do not support any weight. The hydraulic cylinders on the left side are connected together as are the hydraulic cylinders on the right side (Figure 17). This allows the left side suspension to carry 50% of the weight and the right side suspension to carry the remaining 50% of the weight.

On each side, the base end of the cylinders are hydraulically connected to each other. The base end of the left side suspension cylinders **DO NOT** connect to the base end of the right side suspension cylinders. Once each circuit is charged, the circuit is closed. With the left side cylinders connected to each other and the right side cylinders connected to each other (Figure 18), the hydraulic fluid can flow from one cylinder base to the other on the same side. This allows for the load to equalize and permit the axles to move up or down to negotiate ground variations and field approaches. The fast hydraulic fluid flow between cylinders assures each tire carries the same load as the next without spikes.

The rod ends of all suspension cylinders are connected to a low pressure source to keep them full for seal lubrication. Once filled, the valve is closed (Figure 19).



# OPERATION



Figure 16

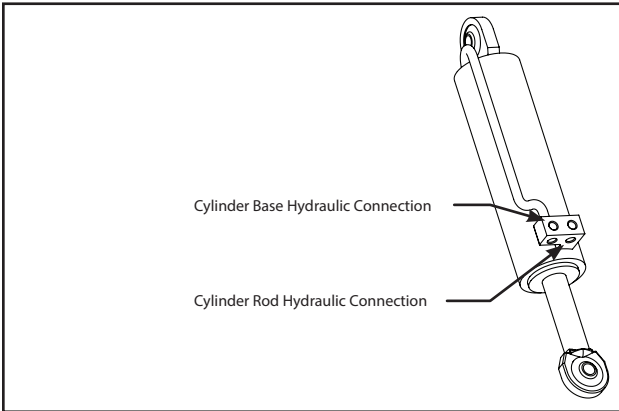

Figure 17

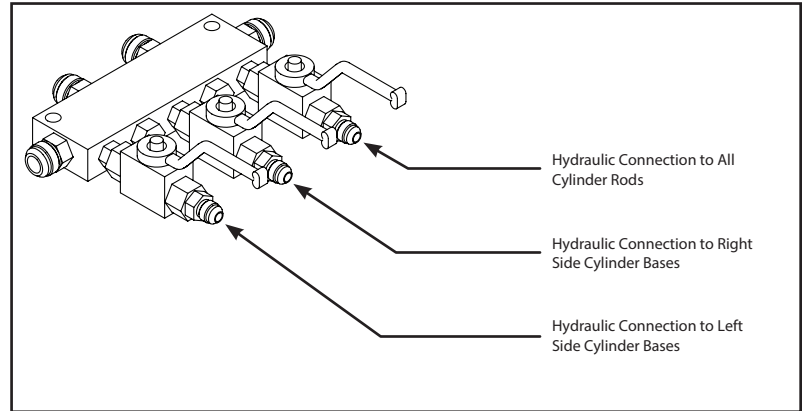

Figure 18

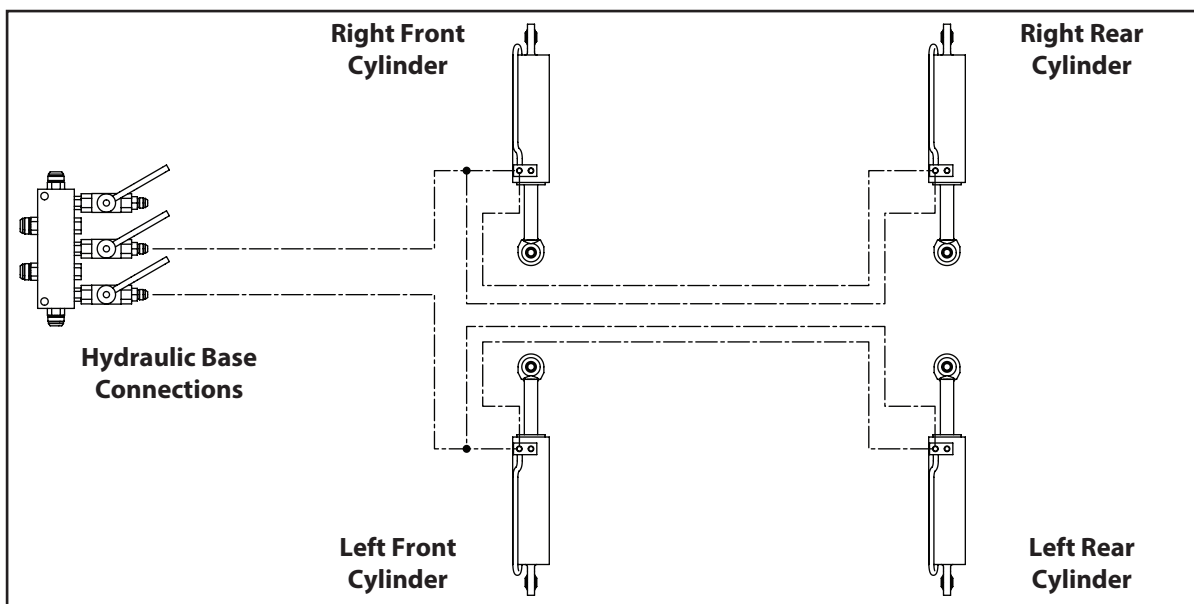
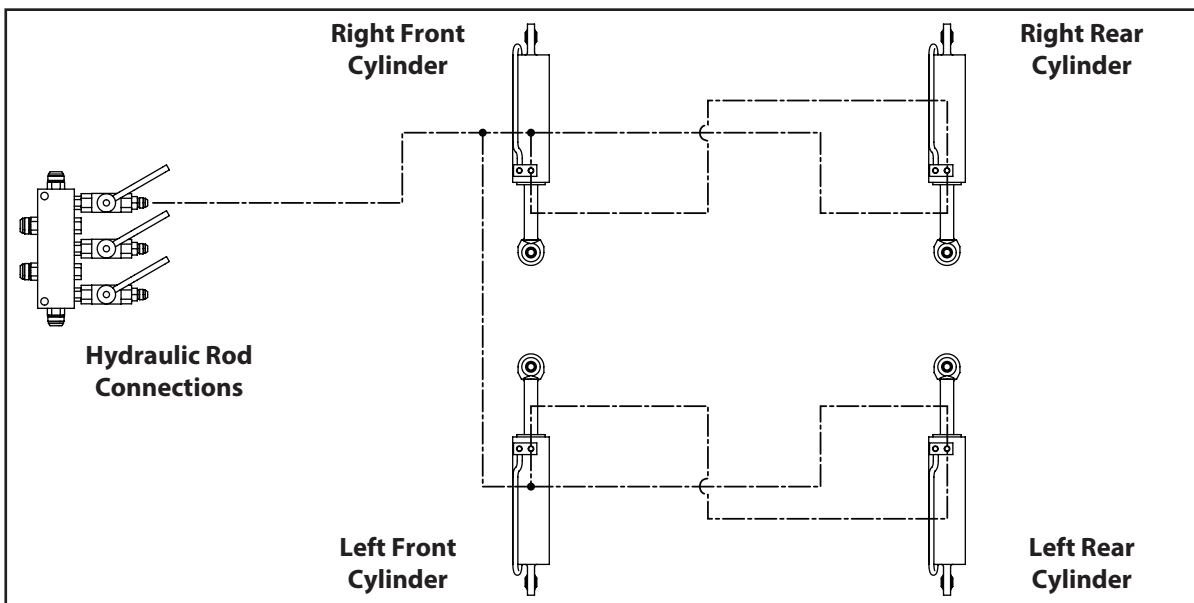

Figure 19



## Suspension Limits

Care must be taken to travel where the suspension system will not be pushed beyond its limits. Each tire can move up or down 7" (17.8 cm) from the center position. Do not exceed these limits or damage to the unit will occur. Promote safe operation and do not go through any deep ditches, over sharp knolls, or grades greater than 9° (15% or 12-2 pitch).



## DANGER

**DO NOT** move this machine through deep ditches, over sharp knolls, or grades greater than 9° (15% or 12-2 pitch).

## Braking System

The hydraulic system on some tractors keep a small amount of pressure in the hydraulic lines even when the control lever is set to the "Float" position. The master cylinder on this machine has a pressure releasing spring which is used to counteract this hydraulic pressure coming from the tractor.

The master cylinder of the braking system is designed to create a vacuum in the hydraulic lines leading to the brake calipers. When the brakes are fully released, the vacuum created pulls on the pistons of the calipers causing them to fully retract which disengages the brakes on the machine. However, for this to happen, the master cylinder must never be full of hydraulic fluid when braking.

### Brake Operation

Tractors with a "Closed Center" or "Open Center" hydraulic circuit:

1. To apply the brakes, the lever must be pulled fully backward.
2. To release the brakes, the lever must be pushed fully forward to the "Float" position.

### Brake Fluid Level Check

1. Apply brakes.
2. Measure the compression of the pressure release spring.
3. If the pressure release spring is compressed to 8" (20.3 cm) or less, hydraulic fluid must be added to the braking system (See "Brake System" on Page 35).

## Vacuum Pump

Positioning the top lever to "Vacuum" (handle pointing to "1") will allow the machine to suction the manure from the pit/storage tank into the unit.

Positioning the top lever to "Pressure" (handle pointed to "2") pressurizes the tank on the unit to discharge the manure. Not all vacuum tanks will have the pressure side of the pump connected.

## Boom Control System

The boom control switch panel connects to the hydraulic manifold via a 37-pin connector (Figure 20).

The boom control switch panel controls the boom swing and each extension of the boom. It also controls the pressure relief valve on the boom, the hydraulic hatch on top of the tank, and the fold-up wings of an attached injector (Figure 21).

Figure 22 identifies each area of the unit the switch panel controls.

The Wings switch controls the hydraulics to the fold out extensions on the injector (if equipped).

Figure 20

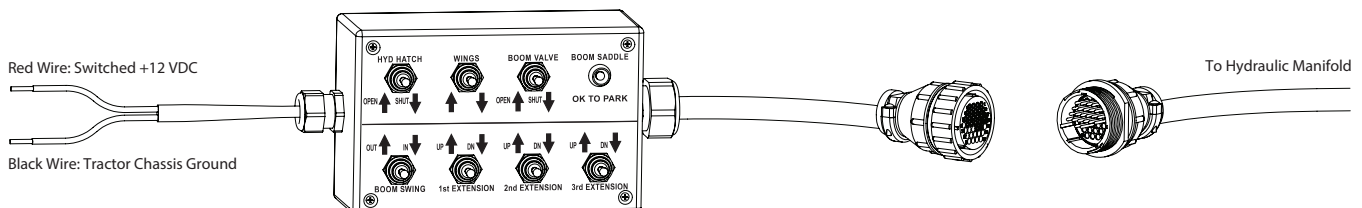

Figure 21

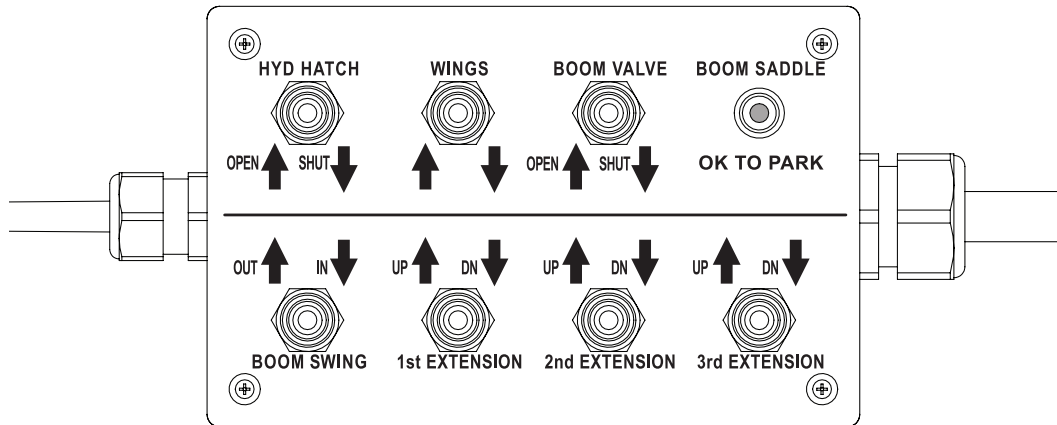
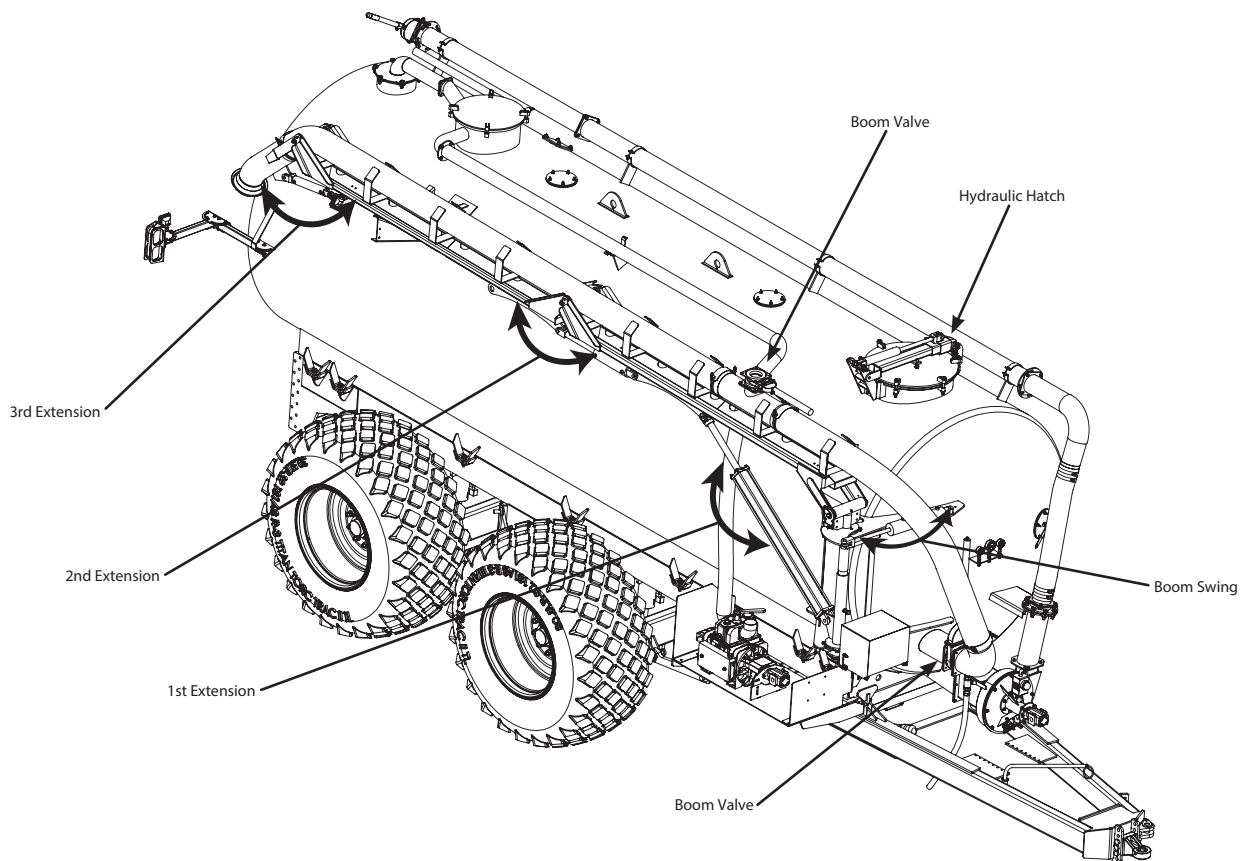

Figure 22



## Boom Operations

After positioning the unit by the source tank,

1. Move the boom off of the Boom Saddle and lower so the flexible suction tip can be attached to the boom (Figure 23).
2. Check the pump to see that it is set to Vacuum (Figure 24).
3. Position the boom over the source tank opening and lower the flexible suction tip into the source tank.
4. Open the Boom Valve. This will open the valve located at the front of the tank and will close the valve located inline with the boom suction tube. With the inline valve closed, a suction will be created when the vacuum pump is engaged allowing the manure to be drawn out of the source tank.
5. Engage the the hydraulic motor to operate the vacuum pump.
6. Monitor the fill gauge and disengage the vacuum pump when the tank is full.

Figure 23

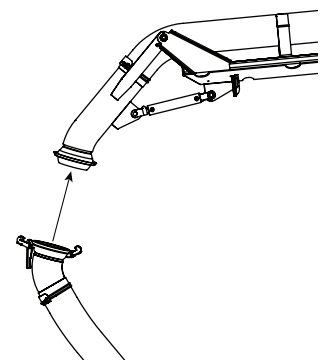

## Boom Operations (Continued)

Figure 24

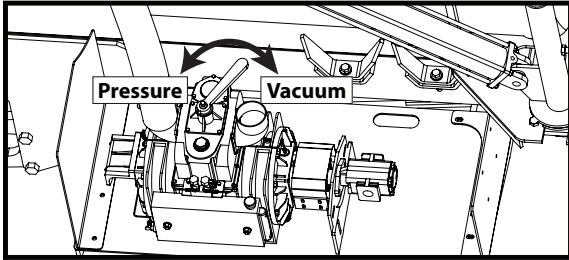
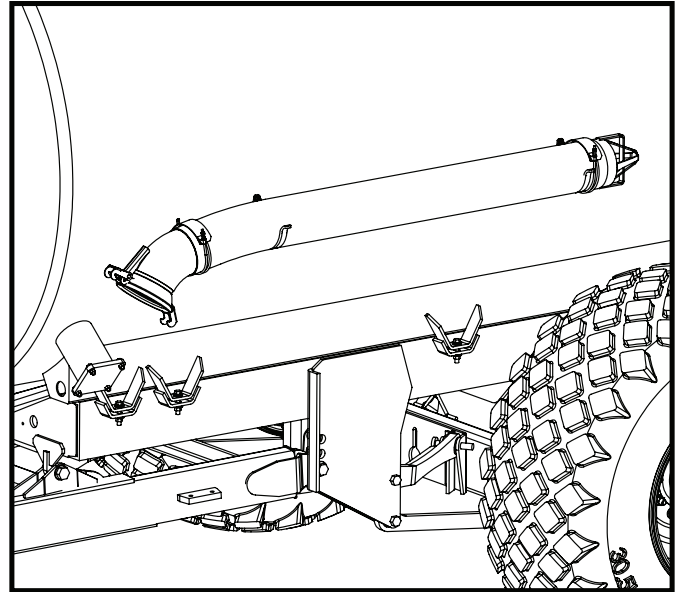

Figure 25



7. Close the boom valve. This will close the valve at the front of the tank and open the inline valve to break the suction in the boom tube. With the inline valve open, the manure in the boom tube will empty back into the source tank.
8. Remove the boom from the source tank and position so the flexible suction tip can be removed and placed back onto its storage hooks on the left side of the unit (Figure 25).
9. Position the boom above the Boom Saddle. The Boom Saddle “OK to Park” light on the control panel will light indicating it is high enough to swing the boom over the saddle.

## Rite Rate Flow System

The Rite Rate Flow System consists of four components (Figure 26):

- Raven SCS660 NVM Controller and associated cables
- Raven 660 PWM Boost Box
- Krohne Optiflux 4100C Electromagnetic Flow Sensor with Signal Converter
- SkyTrak GPS Velocity Sensor

Figure 26

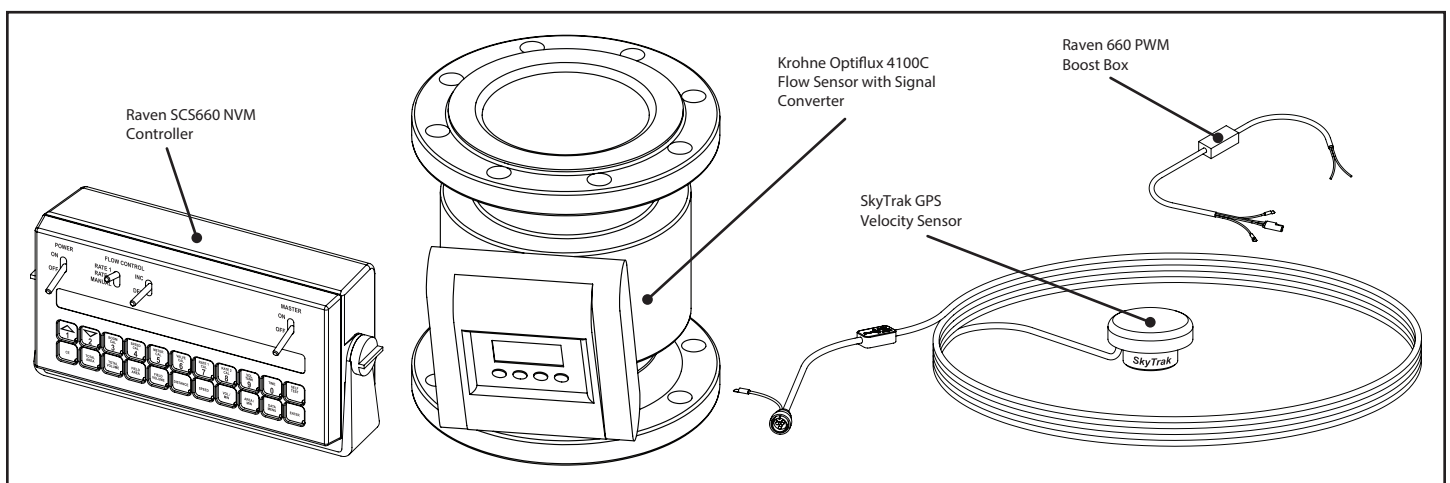

### Raven SCS660 NVM Controller

The Raven SCS660 NVM Controller (Figure 27) monitors and adjusts the flow rate going to the injector. It has two programmable presets and a manual override allowing for a custom application when necessary.

Figure 27

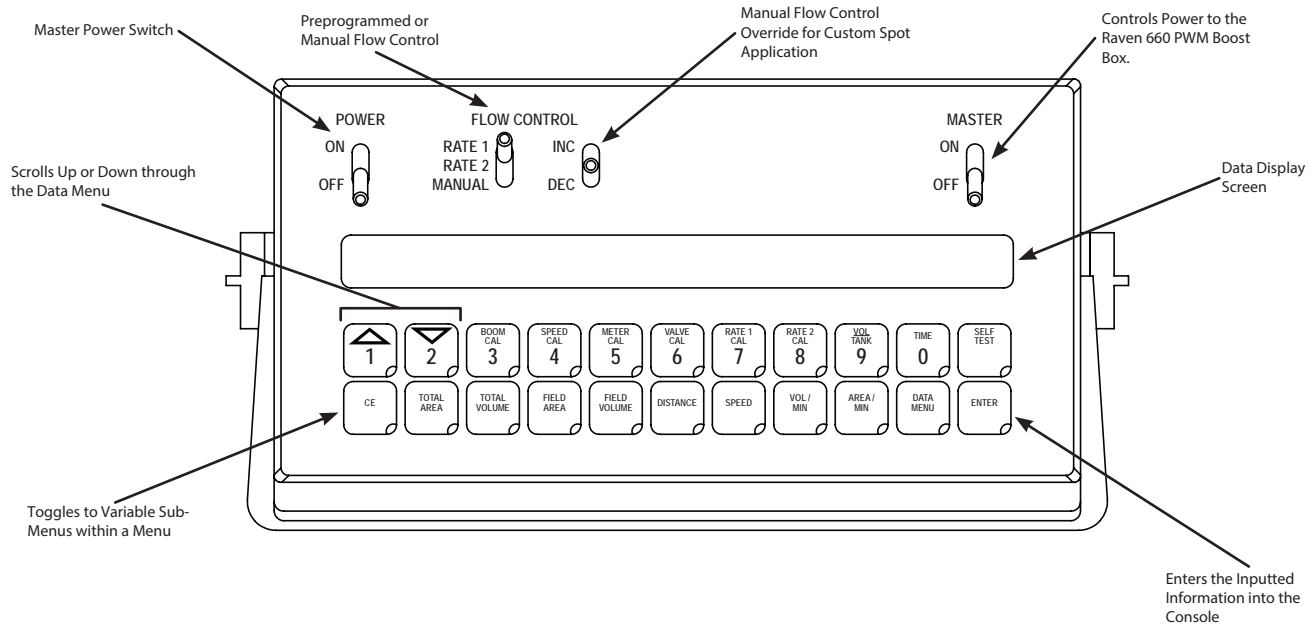

DANGER

**Disconnect power to the Raven SCS660 NVM Controller before jump starting, welding, or charging the battery.**

## Rite Rate Flow System Field Operation

### Pre-Operation Checks

1. Check the hydraulic connections.
2. Before starting the tractor, check all electrical connections at the Raven SCS660 NVM Controller and at the hitch.
3. Start the tractor and turn the Raven SCS660 power **ON** and leave the **MASTER** switch in the **OFF** position. The display on the Raven should light up.
4. Check to see if the Krohne Optiflux Flow Meter is receiving power.
5. Confirm the Raven has the correct programming (if incorrect, see "Rite Rate Flow System Programming" on Page 44).
6. Check to see that the **SPEED CAL** has been set to 598.
7. Check the **BOOM CAL** to see if it is correctly programmed with the proper width (in inches) of your plow/injector toolbar.
8. Check the application rates programmed into **RATE 1 CAL** and **RATE 2 CAL**. If you desire, you can zero out any totals showing for **TOTAL VOLUME**, **TOTAL AREA**, etc.
9. With the tank empty, engage the hydraulics to lower the injector and start the slurry pump. The injector down pressure will be applied but the discharge valve will not open and the pump will not turn with the **MASTER** switch in the **OFF** position. Check the pressure gage at the block to ensure proper down pressure for the injector.
10. Disengage the hydraulic down pressure and lift the injector up.
11. Fill the slurry tank.
12. On the way to the field, check the speed calibration by pressing the button. The speed displayed should be reasonably accurate when compared to the tractor's speed.

### Field Application

1. Upon arrival at the field, make sure the Raven SCS660 has the **POWER** turned **ON**. Set the Flow Control switch to **RATE 1** or **RATE 2** for your desired application rate. Leave the **MASTER** switch **OFF**.
2. Engage the hydraulics to lower the injector and apply down pressure.

## Rite Rate Flow System Field Operation (Continued)

3. Turn the **MASTER** switch **ON** and accelerate up to the desired speed. The Rite Rate system will start application as soon as it detects forward movement by the tractor. Quickly you should notice a value displayed next to Rate on the display. Generally the system will initially overshoot the target rate on startup and then slowly back down to the desired preset rate. While the system is settling to the desired rate, the Raven SCS660 may buzz until the correct application rate is reached (about 15-20 seconds). Rate fluctuations of  $\pm 200$  gallons per acre are not uncommon with this system. A consistent ground speed during application will help reduce rate fluctuations.
4. During application, the operator may switch the **FLOW CONTROL** back and forth between **RATE 1** and **RATE 2** or switch to **MAN** to manually increase or decrease flow rate. To increase the flow rate, press and hold the switch in the **INC** position until the desired flow rate is reached. To decrease the flow rate, press and hold the switch in the **DEC** position until the desired flow rate is reached. The **FLOW CONTROL** can be switched back to **RATE 1** or **RATE 2** at any time and the system will adjust to that flow rate.
5. Near tile inlets and other areas where tillage is desired but application is not, turn the **MASTER** switch to **OFF**. This will shut off the pump and close the discharge valve. The hydraulics may remain engaged and the injector in the ground.
6. When approaching a turn around location or after the tank has emptied, turn the Master switch to Off and wait 3-4 seconds before raising the injector. This allows the discharge valve time to close and the slurry lines to be cleaned out. Raising the injector before discharge valve becomes fully closed may result in the discharge valve remaining partially open. Do not turn with the injector still in the ground, damage will occur!
7. After completing a turn or refilling the slurry tank and returning to where you left off, repeat Field Application steps 1 through 3.
8. The Rite Rate system will store the programmed data for an extended period of time when disconnected from the power source so the Raven should not need to be reprogrammed.

**BALZER**

# Maintenance



## CAUTION

Before performing any maintenance on this machine, turn off the tractor, remove the ignition key, and relieve hydraulic pressure from the hydraulic systems unless otherwise noted.

### Daily and Before Start of Season

#### Before Starting Tractor

1. Check tires for damage and proper air pressure. Repair or replace as needed. Tire air pressure should be as listed in Figure 28 below (for future reference check the box next to the tires on your machine) :

Figure 28

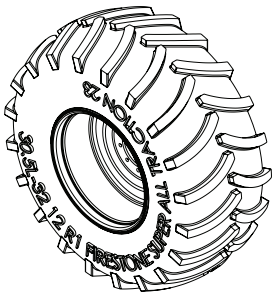

R1 - Lug

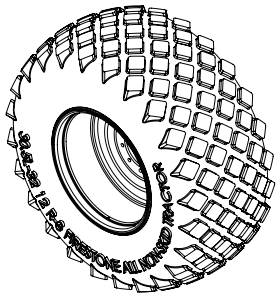

R3 - Diamond

Tire Description	Tire Pressure
<input type="checkbox"/> 28L X 26 R3 - 10 Bolt, 13 3/16" Bolt Circle	26 (180 kPa)
<input type="checkbox"/> 28LR26 R3 - 10 Bolt, 13 3/16" Bolt Circle	54 (372 kPa)
<input type="checkbox"/> 30.5x32 R1 - 10 Bolt, 13 3/16" Bolt Circle	33 (228 kPa)
<input type="checkbox"/> 30.5x32 R3 - 10 Bolt, 13 3/16" Bolt Circle	33 (228 kPa)
<input type="checkbox"/> 30.5LR32 R1 - 10 Bolt, 13 3/16" Bolt Circle	52 (359 kPa)
<input type="checkbox"/> 30.5LR32 R3 - 10 Bolt, 13 3/16" Bolt Circle	52 (359 kPa)
<input type="checkbox"/> 850/50 30.5 - 10 Bolt, 13 3/16" Bolt Circle, 10 Ply	37 (256 kPa)
<input type="checkbox"/> 900/60 32 R1 - 10 Bolt, 13 1/4" Bolt Circle	35 (241 kPa)

2. Torque all lug nuts to 450 ft/lbs (before first use after purchase, daily for the first five [5] days, before first use of season, and after replacing tires).
3. Inspect suspension system for damage. Repair or replace as needed.
4. Inspect all hoses, connections, and reservoirs for leaks. Repair or replace as needed.



## WARNING

Using oils and fluids other than those approved and specified for each system may result in damage to the machine.

5. Check all oil and fluid reservoirs for proper levels. Fill to proper level with the oil or fluid approved for that system. The oil level in the vacuum pump must not go below the minimum amount shown in the site gauge (Figure 29). If it does, damage to the pump will occur and total pump failure may occur. See "Vacuum Pump" on Page 37 for full maintenance of the pump. If the oil reservoir on the slurry pump needs oil, fill until the oil is in the middle of the site glass (Figure 30).

Figure 29

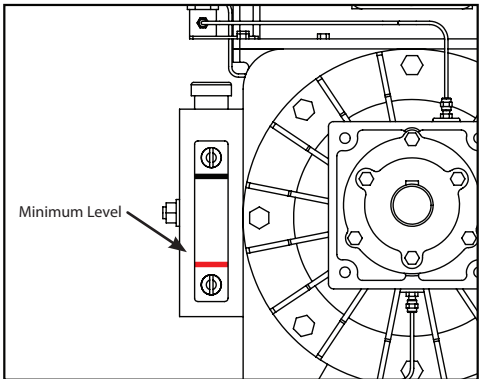
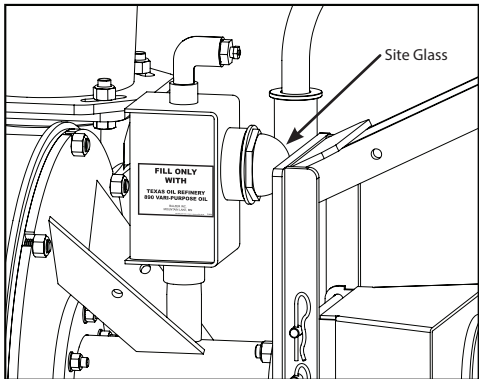

Figure 30



6. Inspect all moving components for damage or excessive wear. Repair or replace as needed.
7. Check braking system for damage or excessive wear. Repair or replace as needed.



## Daily and Before Start of Season (Continued)

8. Check for solid, hard, or frozen substances on all moving parts. Remove substance to avoid damaging the machine.
9. Grease all points shown in Figures 31, 32, 33, 34, and 35. Grease steering system according to "Steering System Lubrication" on Page 30. Grease vacuum pump according to "Vacuum Pump" on Page 37.

**Figure 31**

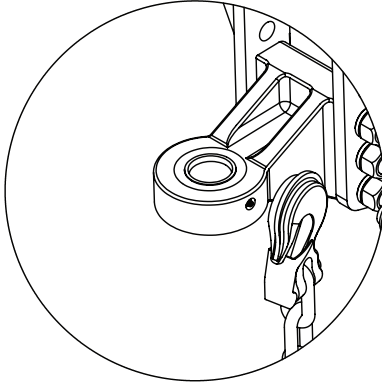

Grease points on both sides of Bull Pull hitch.

**Figure 32**

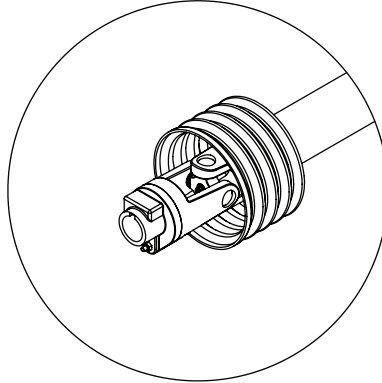

Grease points on both universal joints of the PTO shaft and on the shaft itself.

**Figure 33**

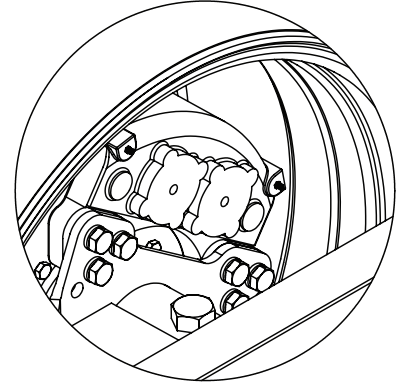

Two (2) grease points on each brake caliper.

**Figure 34**

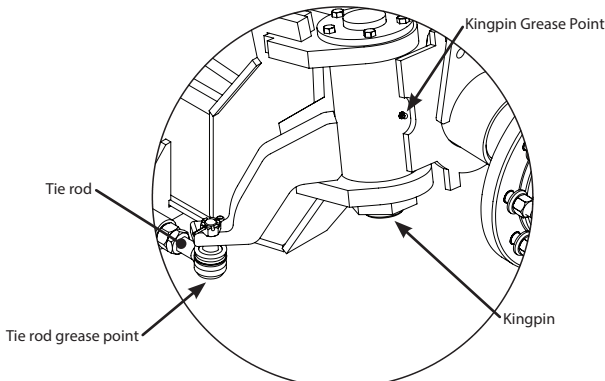

Apply grease to both grease points on the tie rod and the kingpin grease point on each wheel. If the kingpin grease point is connected to a grease line, the grease point is located on the right side rear of the frame. If there is no kingpin grease point, the kingpin has a poly bushing and does not need any grease.

**Figure 35**

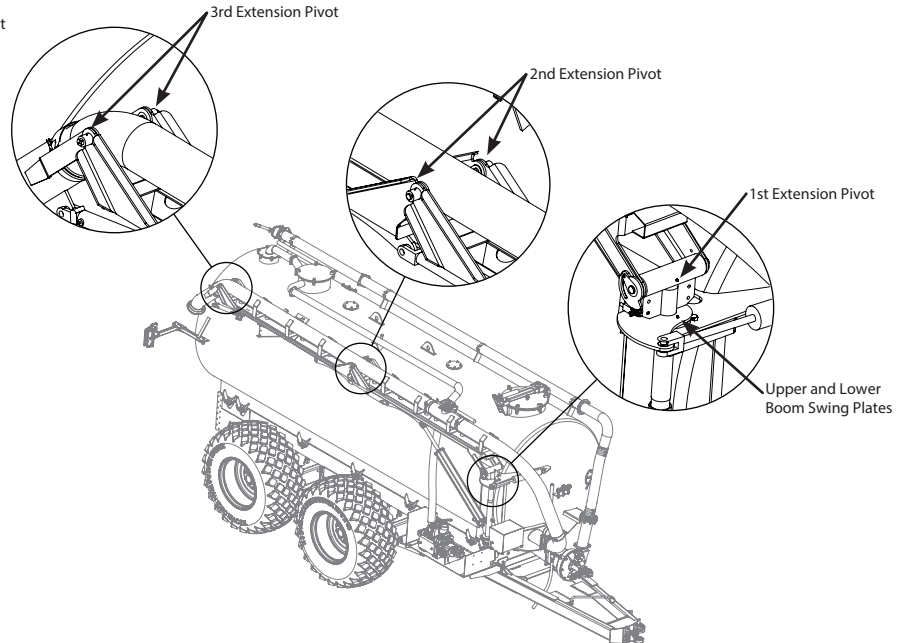

### After Starting Tractor

10. Check braking system for proper working operation.
11. Recheck all hoses and connections for leaks.
12. Check all lights for proper operation. Replace as needed.
13. Grease according operational requirements stated on the machine.



# WARNING

Hydraulic and brake lines are under high pressure when tractor is running. Hydraulic fluids can become hot enough to cause serious burns. Use proper safety equipment when checking lines.

## Every 40 Hours of Operation

1. Check all oil and fluid reservoirs for proper level. Fill as needed with correct oil or fluid. The vacuum pump has a site gauge to check the oil level in the pump (Figure 36).
2. Grease wheel bearings.
3. Torque lug nuts to 450 ft/lbs.

Figure 36

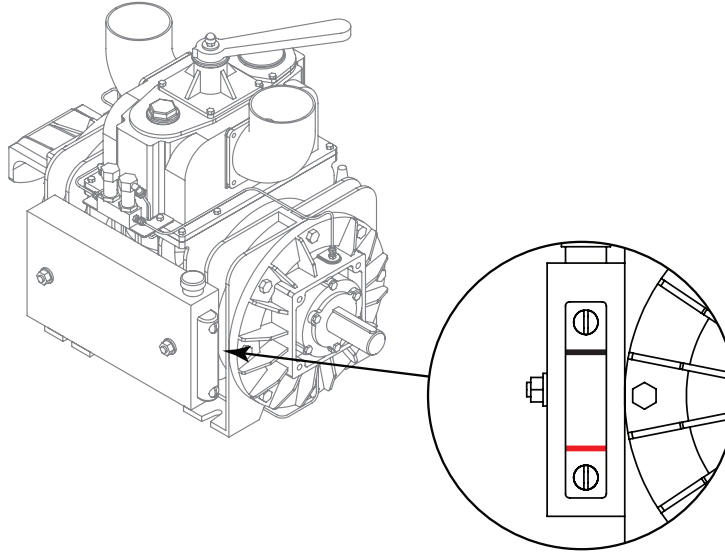

## End of Season/Preparing for Storage

1. Change all oils and fluids with approved oils or fluids for that system. Fill the slurry pump oil reservoir to the middle of the site glass.
2. Grease all grease points.
3. Open all drain plugs and doors to completely empty the machine.
4. Clean exterior and interior of unit thoroughly with a high pressure washer.
5. Apply a thick coat of grease on all cylinder rods before storing the unit.
6. Perform a complete lubrication of the unit.
7. Check for any oil or fluid leaks. Repair or replace as needed.
8. Store unit indoors.



# CAUTION

Thoroughly grease the steering system after pressure washing.

## Steering System Lubrication

There is one (1) grease fitting located on each kingpin. This fitting may be attached to a grease line placing the grease point on the right side rear of the frame. If the kingpin does not have a grease point, the kingpin then has a poly bushing which requires no grease.

There is one (1) grease fitting located on each end of the tie rod.

When greasing the kingpins, alternate between having the wheels straight one day, turned to the left, the next day, and then turned to the right the following day. This process ensures the grease is getting to all surfaces of the kingpin.

Apply grease daily to the grease points until fresh grease can be seen being pushed out from it. When conditions are dry and dusty, the kingpins and tie rod will require greasing more often.

Proper steering is dependent upon adequate greasing.

**MAINTENANCE****Hub Lubrication**

The wheel bearings should be checked for wear and/or damage annually (Figure 37). Repack with grease before first use of the season. Use an EP2 grease. The inside of the hub is filled about 75% with grease to allow for heat expansion.

After the wheel bearings have been greased and placed back on the spindle, grease the washer and place on the spindle, then thread the castle nut. Tighten the nut using a wrench and rotate the hub in the opposite direction. The wrench should not drag against the hub when tightening. Tighten until the hub doesn't rotate freely using one hand. Back the nut off 1/2 turn, retighten the nut to the next slot and insert the locking pin (either a roll pin or a split cotter pin). The hub should rotate with one hand and, depending on the speed of rotation, the radial momentum will keep the hub rotating for a partial (1/8 to 1/4) turn after letting go of it. This should provide for the desired preload. If using a split cotter pin, bend the ends to secure the pin, then replace the hub cap gasket and hub cap.

Recheck the preload after 5 to 10 hours of use.

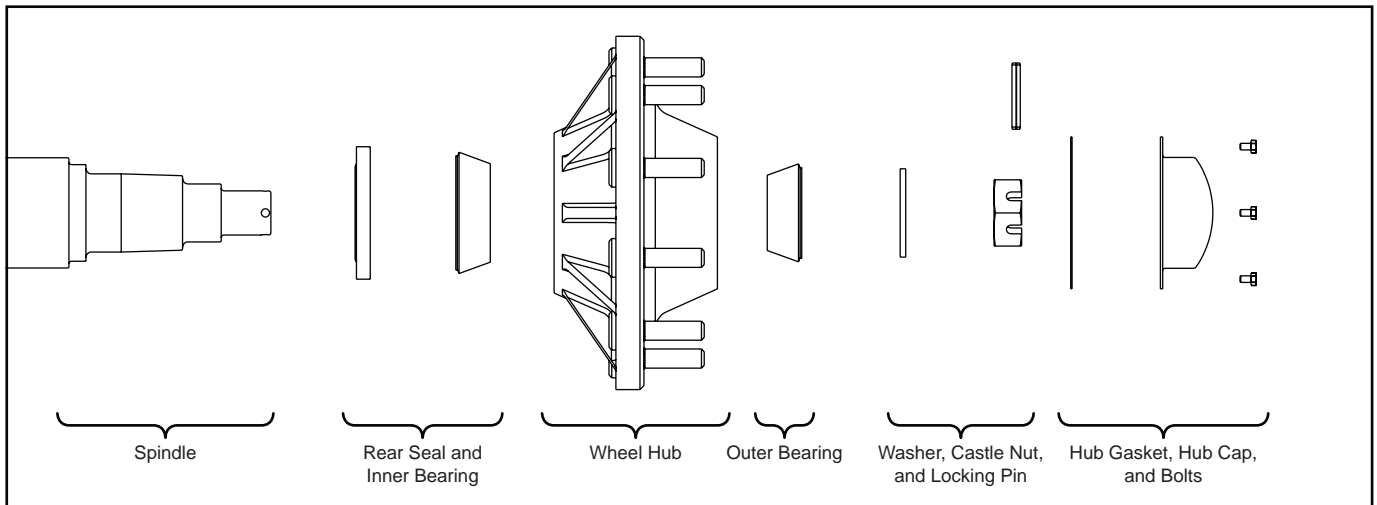
**Figure 37****Hitch Lubrication**

The Bull Pull hitch has two (2) grease fittings, one on each side (Figure 38). These should be greased daily under normal conditions.

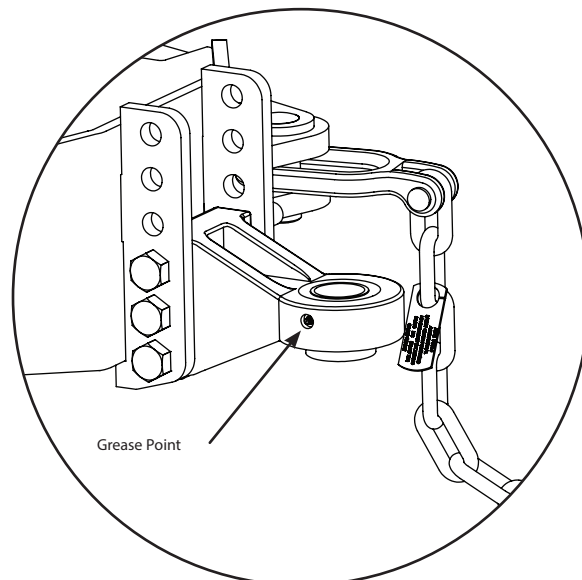
**Figure 38**

## PTO Shaft Lubrication Specifications

Lubricate all fittings (Figure 39) with a quality EP lithium grease meeting the NLGI #2 specifications and containing no more than 1% molybdenum disulfide (ex. Shell Super Duty or equivalent).

An EP lithium grease meeting the NLGI #2 specification and containing 3% molybdenum disulfide may be substituted for the telescoping members only.

Figure 39

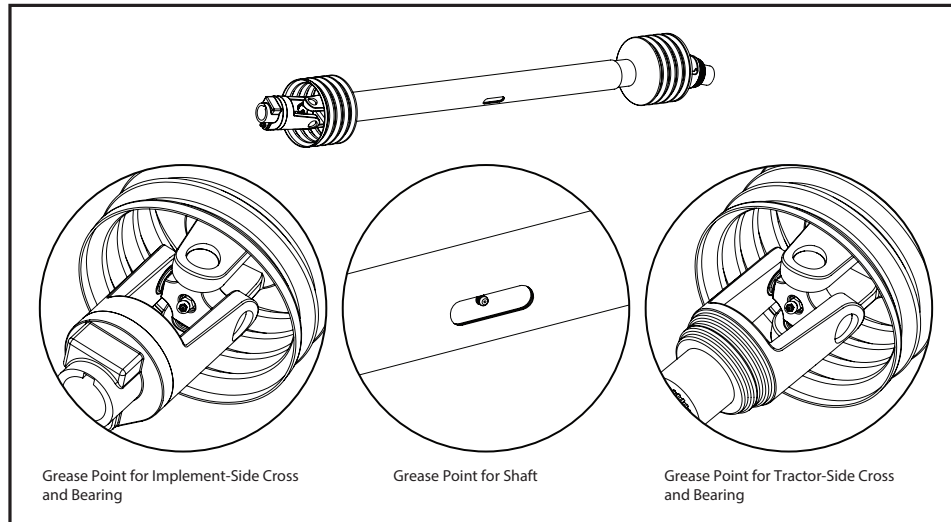



# DANGER

**REPLACEMENT PARTS ARE NOT LUBRICATED!**  
**Proper lubrication must be done at time of assembly.**

### Grease Recommendations

Location	Interval	Amount
Cross and Bearing	Daily	1 Pump ea.
Telescoping Shaft	Daily	4-8 Pumps

Replacement parts must be lubricated at time of assembly. Use the amount of grease listed above per location then follow lube recommendations above for lubricating intervals.

### Lubrication

Lubricate with approved quality grease daily before starting work (Figure 32). Clean and grease the implement input driveline before each prolonged period of non-use.

Telescoping members must have lubrication to operate successfully regardless if a grease fitting is provided for that purpose. Telescoping members without fittings should be pulled apart and grease added manually to the inside of the outer telescoping member (Figure 40).

For any additional maintenance of the PTO shaft, please refer to the manufacturer's book that came with the PTO shaft.

Figure 40

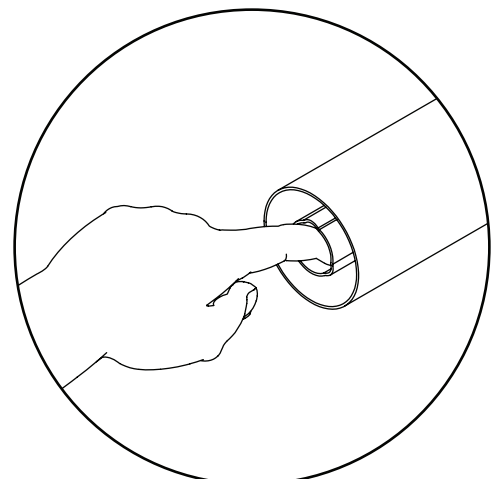

## Suspension Height Adjustment

1. Position the tractor and machine on level ground.
2. Connect the two (2) yellow marked hoses to the tractor.
3. Completely lower the machine by disengaging the straight steer function and opening all ball valves. Once the machine is completely lowered, close all ball valves.
4. Engage the straight steer function.
5. Open the Left Side Base End ball valve and the Rod End ball valve slowly and simultaneously (Figures 41 and 42). The cylinders can be filled by opening the valves a little. This will provide more control while filling the cylinders.
6. Raise the machine until the measurement of both exposed rods of the left cylinders equals 14" (35.6 cm). This will leave the necessary average of 7" (17.8 cm) of exposed rod (Figure 43).
7. Close both valves.
8. Repeat for the right side cylinders.

The machine now has the suspension properly adjusted for operation.

**Figure 41**

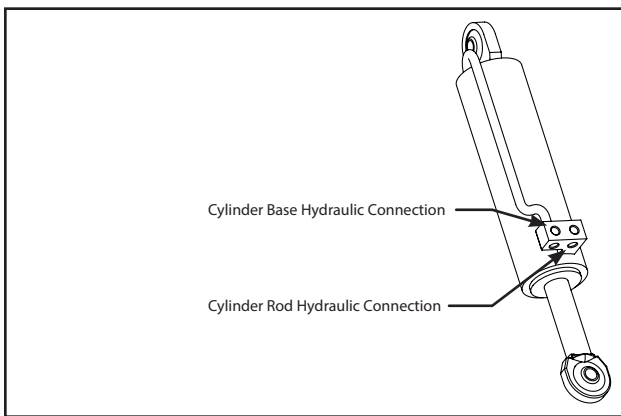

**Figure 42**

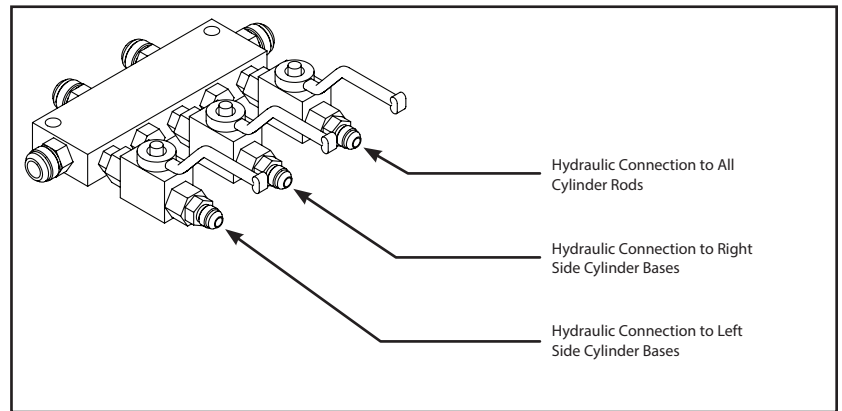

**Figure 43**

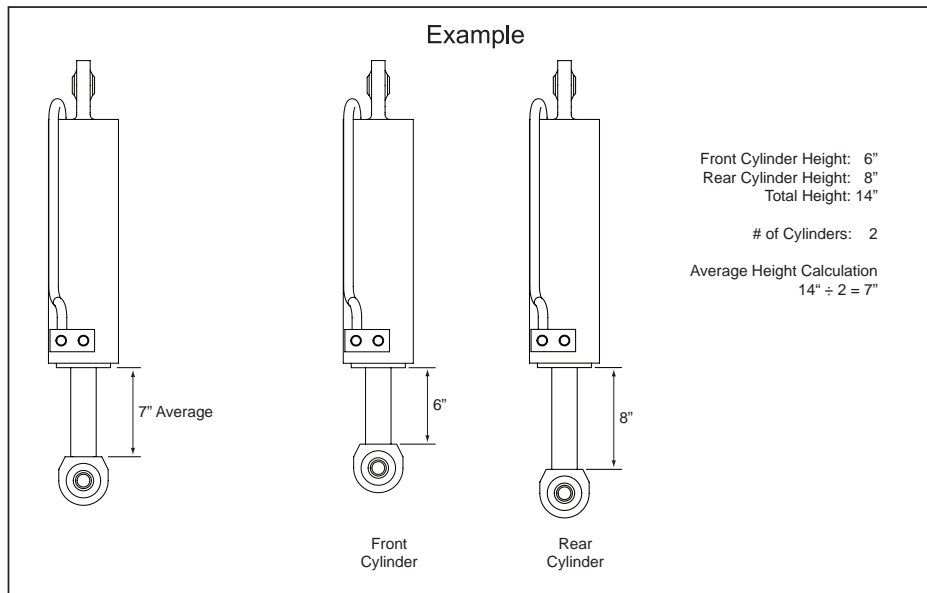

## Steering Axle Toe Adjustment



# DANGER

**DO NOT work under any part of this machine without proper support devices placed between the ground and the axles. Block the wheels to keep the machine from rolling.**

At the start of each season the steering axle toe should be checked for proper adjustment. Follow these steps to check and, if necessary, adjust the toe of the steering axle.

1. Lock the straight steer so the steering axle wheels are in line with the straight axle.
2. Raise the steering axle using a bottle jack or other device designed to safely lift the machine enough so both wheels of the steering axle are not touching the ground.
3. Before proceeding, place support items, such as jack stands with a sufficient weight rating, under the axle or the frame to support the machine. **The device lifting the machine should NOT be used as a support device. Place blocking or wheel chocks in front and back of each wheel of the straight axle to keep the machine from rolling.**
4. Measure the wheel attached to the steering hydraulic cylinder first. From the vertical center of the wheel, measure from the inside front of the rim to the frame. Then measure from the inside rear of the rim to the frame (Figure 44).

Figure 44

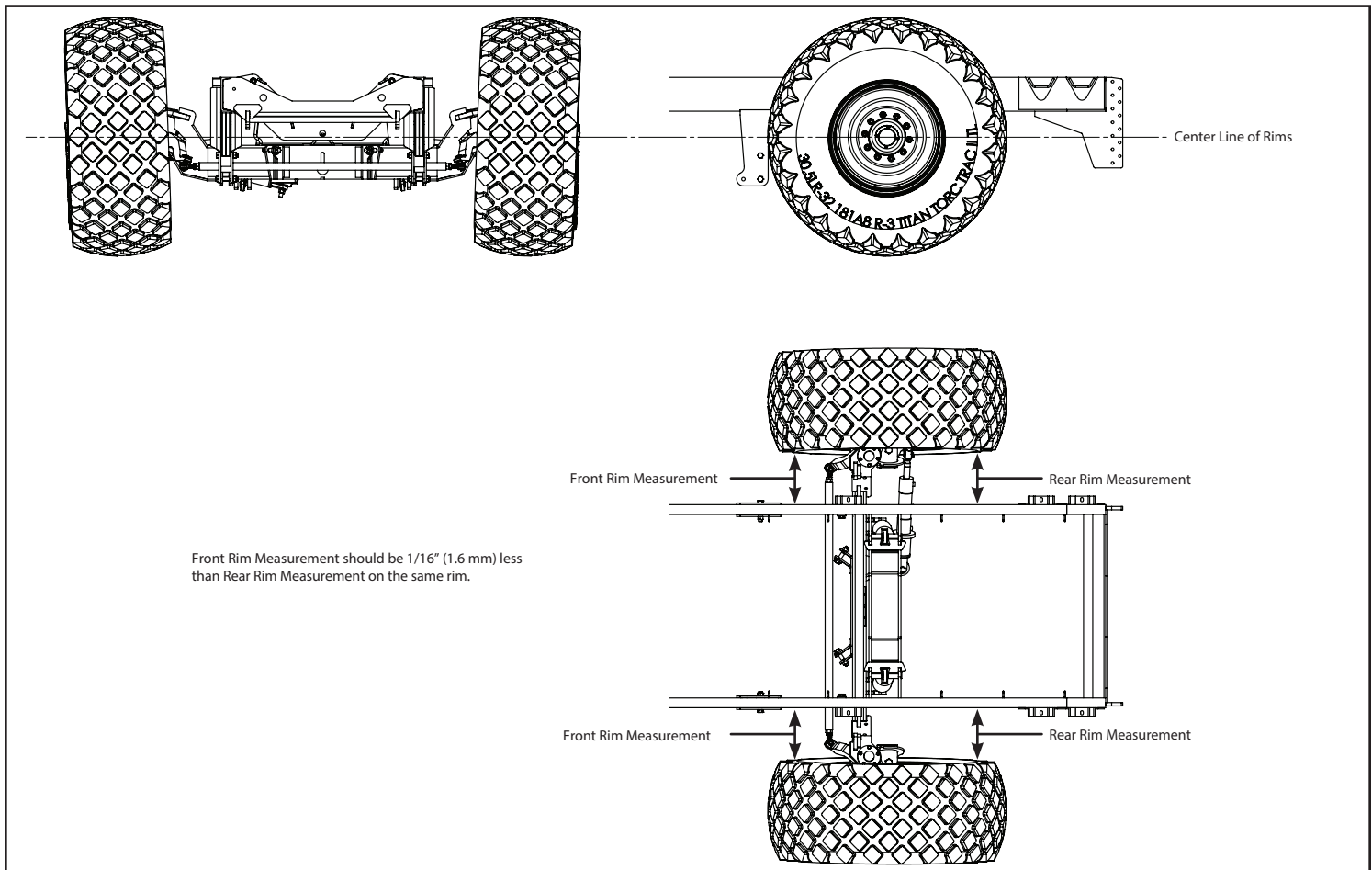

5. The inside front measurement should be 1/16" (1.6 mm) shorter than the inside rear measurement.
6. If adjustment is needed, loosen the steering hydraulic cylinder's clevis clamp nut and bolt. The clevis is threaded onto the rod of the cylinder. Using a wrench on the cylinder rod, rotate the rod for proper toe adjustment (Figure 45). Do not tighten the clevis clamp nut and bolt yet.
7. Measure the other steering wheel. From the vertical center of the wheel, measure from the inside front of the rim to the frame. Then measure from the inside rear of the rim to the frame (Figure 44).
8. The inside front measurement should be 1/16" (1.6 mm) shorter than the inside rear measurement.

**MAINTENANCE****Steering Axle Toe Adjustment (Continued)**

9. If adjustment is needed, loosen both jamb nuts on the tie rod (Figure 46). Rotate the direction needed to set the proper toe (Figure 47). Do not tighten the jamb nuts yet.

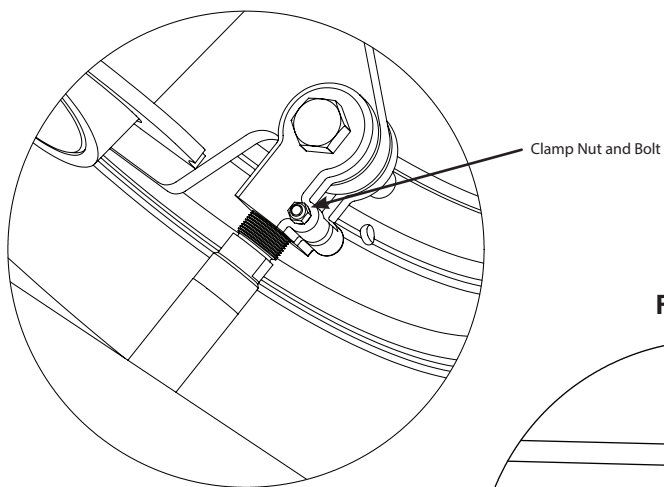
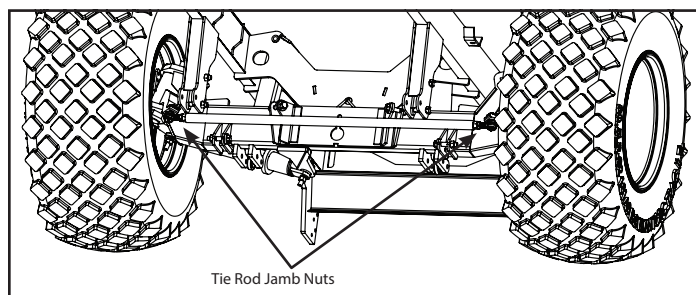
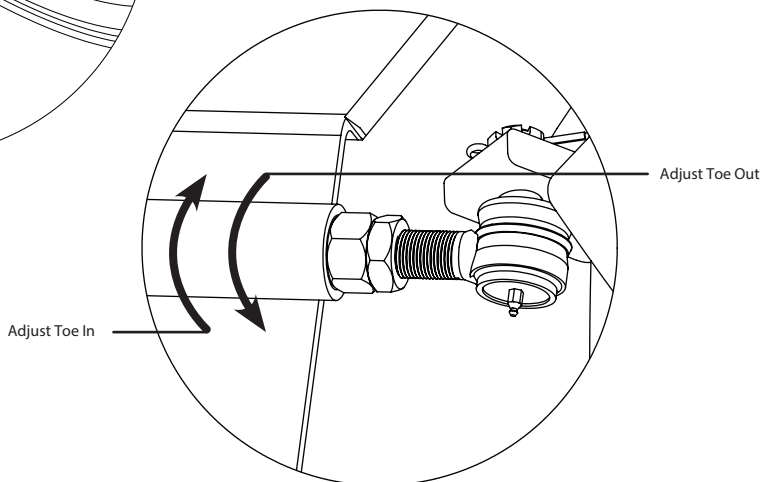
**Figure 45****Figure 46****Figure 47**

10. Measure both rims again for proper toe setting and readjust as necessary.  
11. Tighten both jamb nuts on the tie rod and tighten the steering hydraulic cylinder's clevis clamp nut and bolt.

**Brake System****Adding Brake Fluid**

1. Attach the jumper hose (Part #: 72182) between "A" port and "B" port (Figures 48 and 49).

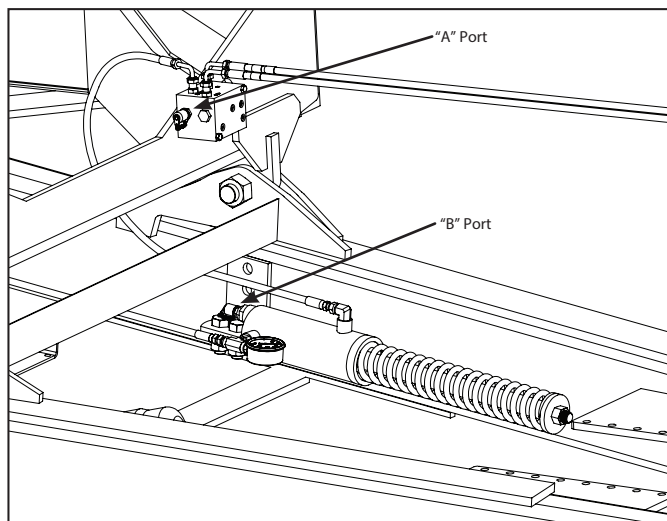
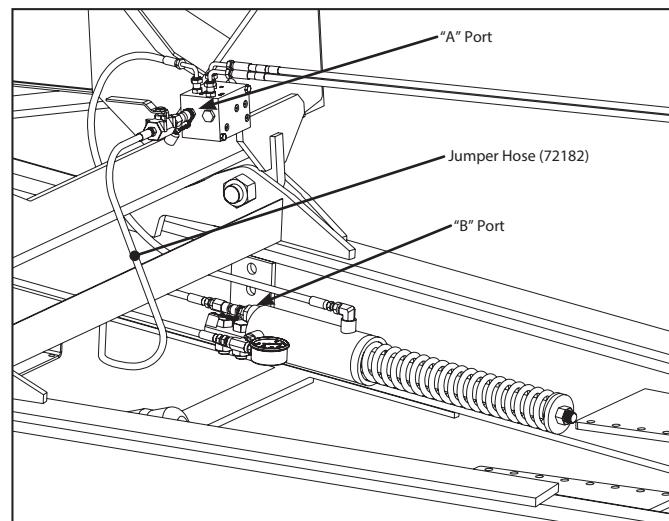
**Figure 48****Figure 49**

## Braking System (Continued)

Figure 50

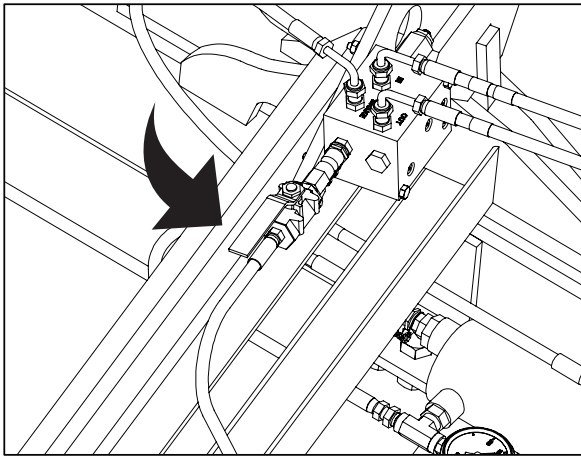

To open the ball valve on the Bleeder Hose, rotate the handle so that it is inline with the hose.

Figure 51

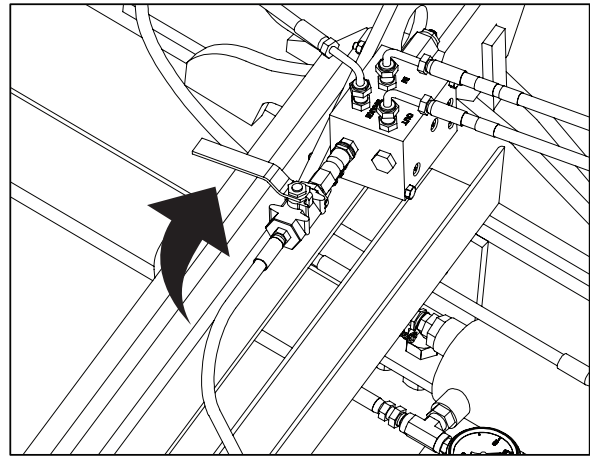

To close the ball valve on the Bleeder Hose, rotate the handle so that it is perpendicular with the hose.

2. Connect the 1/4" hydraulic brake hoses (Red) to the tractor.
3. Open ball valve on jumper hose (Figure 50).
4. Apply and hold pressure to braking system from tractor hydraulics.
5. Relieve all pressure from the 1/4" hydraulic brake hoses (Hoses with Red stripes).
6. Close ball valve on jumper hose (Figure 51).
7. Remove jumper hose from "A" port and "B" port.
8. Apply and hold pressure to braking system.
9. Open bleeder screw on any brake caliper to adjust the brake master cylinder (Figure 52).
10. Allow the pressure releasing spring on the brake master cylinder to compress to 14" (35.6 cm) (Figure 53).

### Bleeding the Brake System

1. Attach the jumper hose (Part #: 72182) between "A" port and "B" port (Figures 48 and 49).
2. Connect the 1/4" hydraulic brake hoses (Red stripes) to the tractor.
3. Apply and hold pressure to braking system from tractor hydraulics.
4. Open ball valve on jumper hose (Figure 50).
5. Loosen bleeder screw on brake caliper closest to the brake master cylinder first (Figure 52).
6. After air bubbles have stopped, tighten bleeder screw.
7. Repeat Steps 5 and 6 until all brake calipers have been bled.
8. Relieve all pressure from the 1/4" hydraulic brake hoses (Red).
9. Close ball valve on jumper hose (Figure 51).

Figure 52

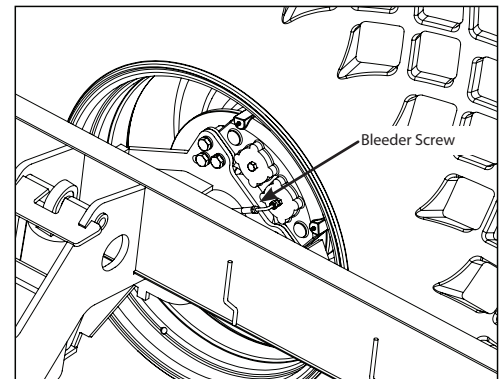
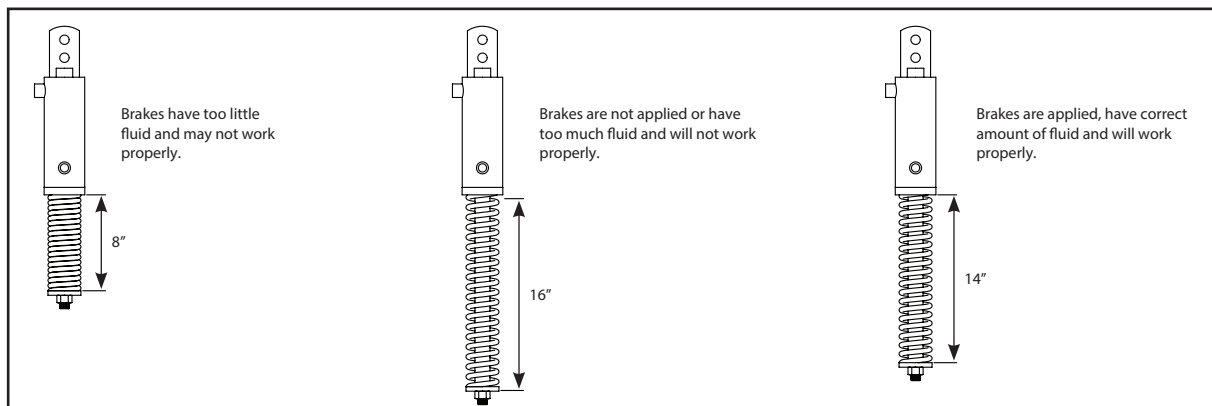

Figure 53





## Braking System (Continued)

10. Remove jumper hose from "A" port and "B" port.
11. Apply and hold pressure to braking system.
12. Open bleeder screw on any brake caliper to adjust the brake master cylinder (Figure 52).
13. Allow the pressure releasing spring on the brake master cylinder to compress to 14" (35.6 cm) (Figure 53).

Figure 54 shows the schematic for the Brake System.

Figure 54

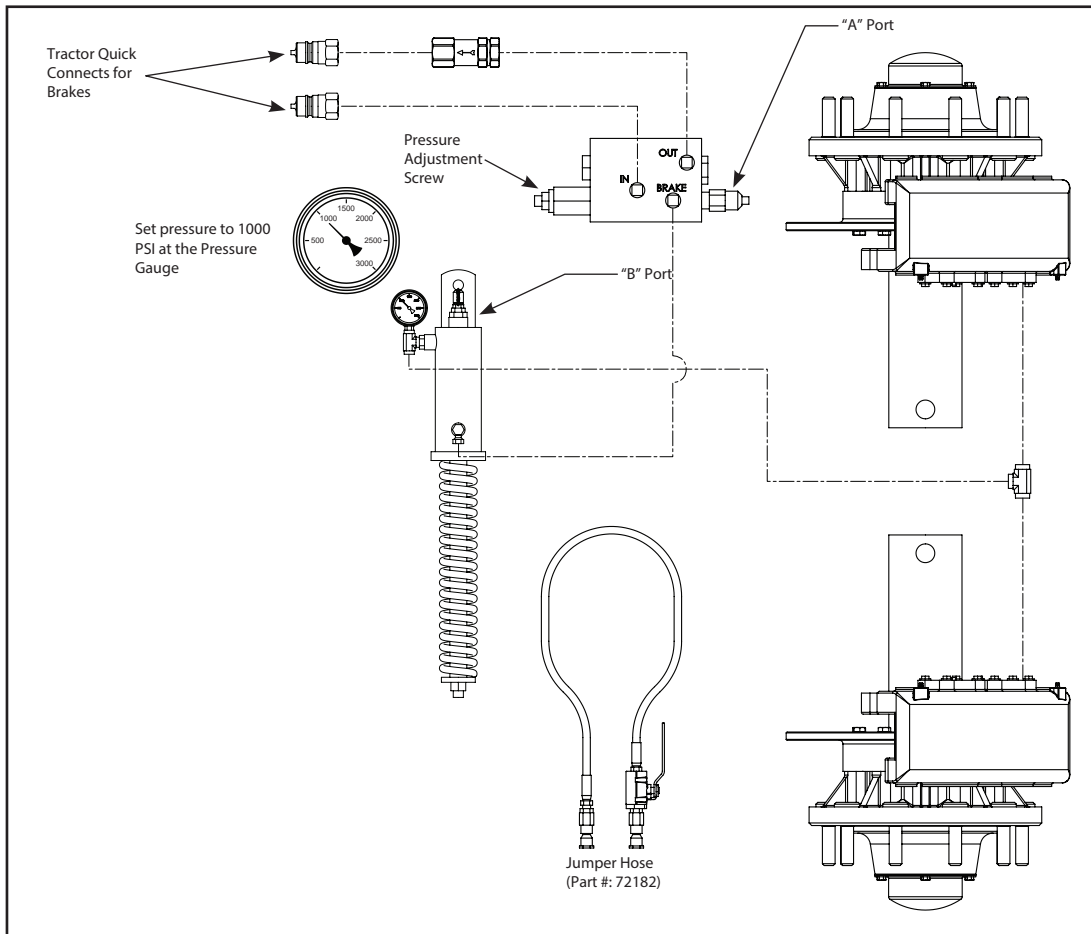

## Vacuum Pump

### Before Start of Season

1. Check the lubricating oil level on the site gauge (Figure 55). Fill the oil reservoir if necessary and without over filling. Use an ISO VG 150 oil (recommended: Shell Vitrea 150, Mobil Rubrex 900, or BP Energol CS 150).
2. Clean the filters on the air injection ports (Figure 56).
3. Check the internal vanes of the vacuum pump for excessive wear. Remove the vane inspection screw and insert a  $\frac{3}{16}$ " metal rod with a tapered end into the inspection port (Figure 57). Rest the rod on the vane rotor and mark the rod. Rotate the drive shaft by hand until the rod connects with the vane slot then mark the rod again. Remove the rod and measure the distance between the marks. If the distance is greater than  $\frac{3}{8}$ ", the vanes need to be replaced (Figure 58). Contact your authorized Balzer dealer for assistance in getting replacement vanes for your vacuum pump.

Figure 55

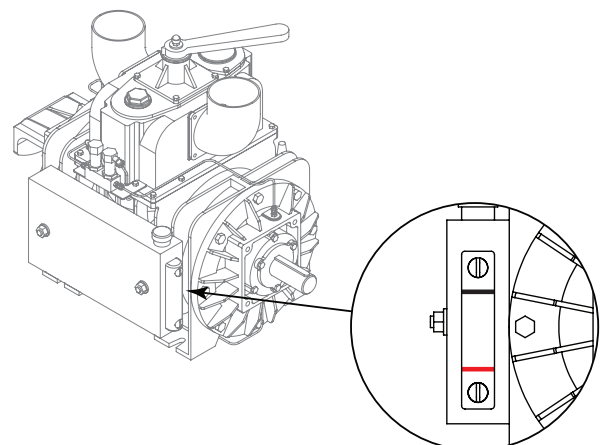

## Vacuum Pump (Continued)

Figure 56

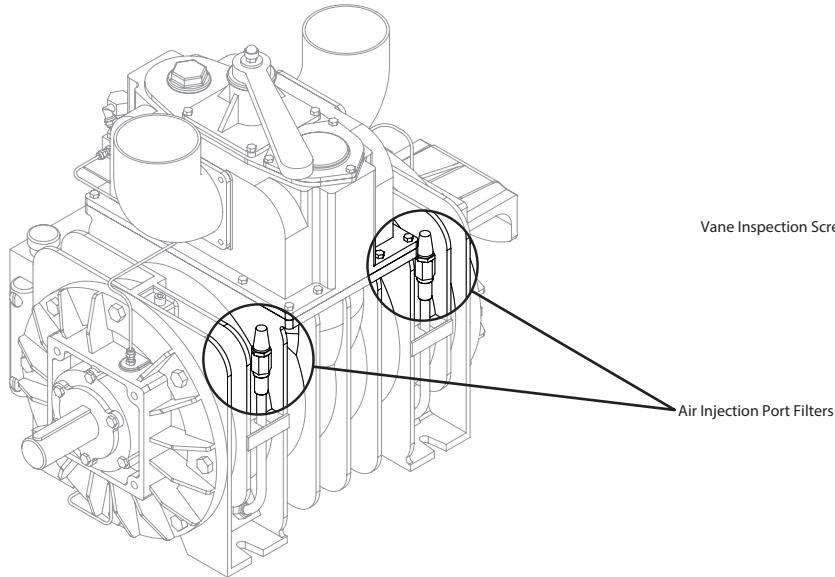

Figure 57

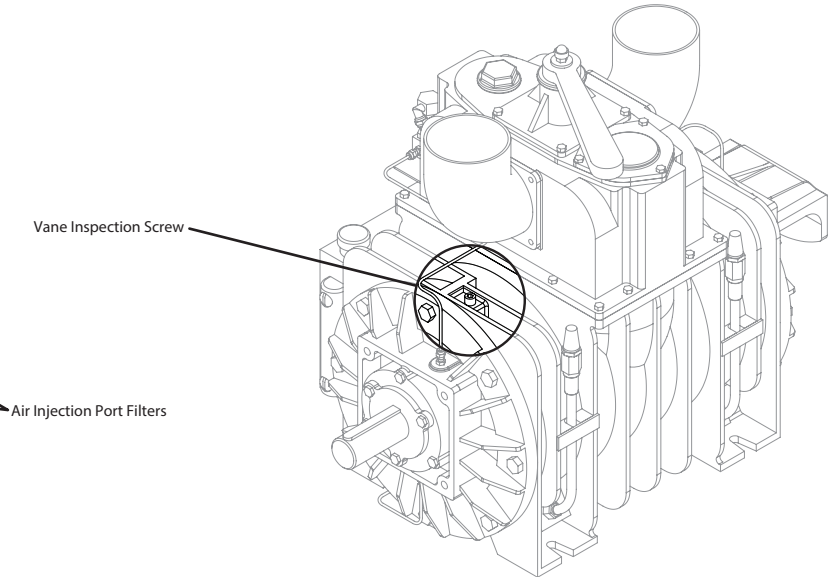
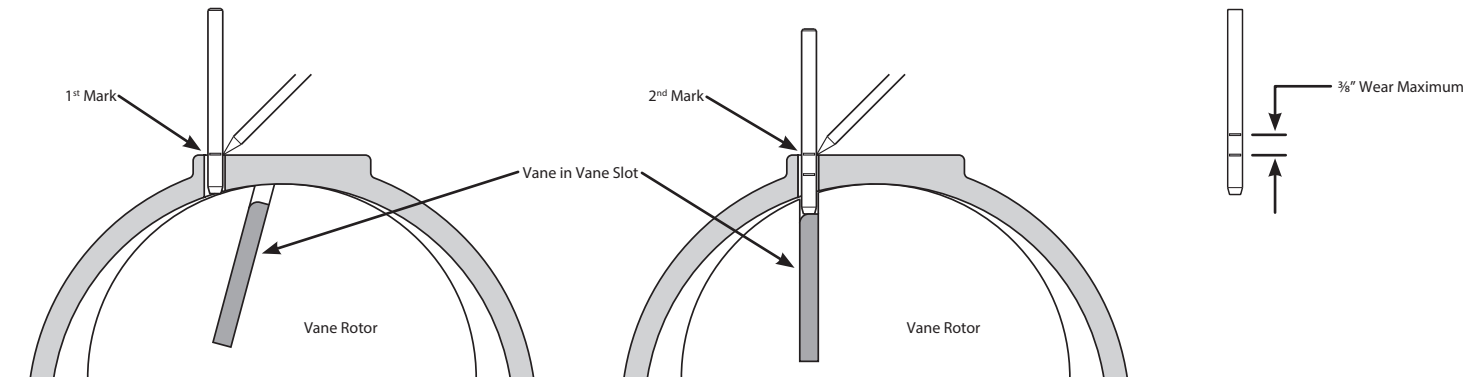

Figure 58



4. Grease the front bearing. Care should be taken to avoid over greasing the bearing as this could damage the bearing seals.
5. Check the vacuum and pressure manifold ports for any obstructions or debris by removing the connected hoses and visually inspecting. Remove any obstructions or debris.
6. Clean the pump by moving the vacuum/pressure valve to neutral. Run the pump at idle speed and pour in one (1) pint of diesel fuel. Run the pump for about 20 to 30 seconds then move the suction valve to vacuum to blow out the diesel fuel. Repeat until the diesel fuel comes out clean.
7. After cleaning, pour 2 oz. of recommended lubrication oil (see oil recommendations in Step 1) into the vacuum manifold. Reattach the vacuum and pressure hoses to the vacuum pump.

### Daily Maintenance Checks

1. Check the lubricating oil level on the site gauge (Figure 55). The oil must not go below the minimum indicator line on the site gauge otherwise damage to the oil pump will occur and unnecessary wear and damage will occur to the vacuum pump.
2. With the vacuum pump engaged, check the vacuum pressure gauge for proper pressure.

### Every 40 Hours of Use

1. Clean the filters on the air injection ports (Figure 56).
2. Check the drip rate of the automatic oilers by looking at the oiler tubes and counting the number of drops produced in 30 seconds (Figure 59). The rate should be no less than 15 and no more than 20 drops in 30 seconds. If the number of drops is outside this range, adjustments to the automatic oilers will be needed (See "Vacuum Pump Automatic Oiler Adjustment" on Page 39).

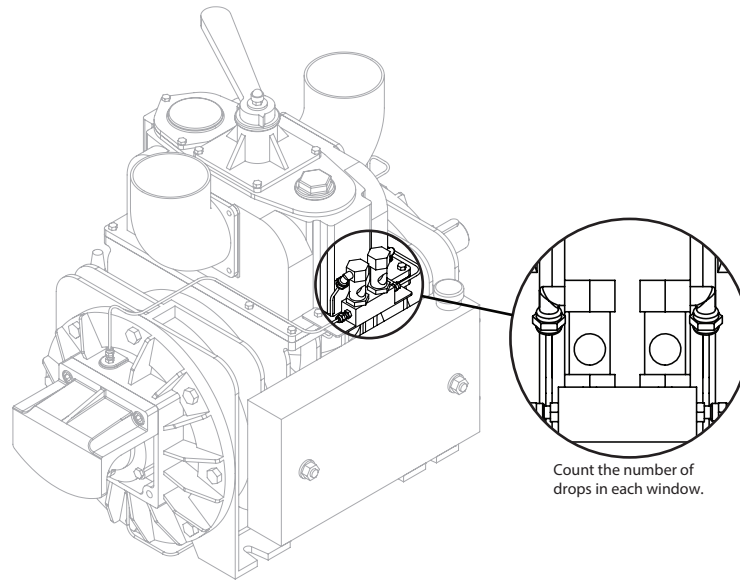
**MAINTENANCE****Vacuum Pump (Continued)****Figure 59****End of Season/Preparing for Storage**

1. Check the vacuum and pressure manifold ports for any obstructions or debris by removing the hoses connecting to them and visually inspecting. Remove any obstructions or debris.
2. Clean the pump by moving the vacuum/pressure valve to neutral. Run the pump at idle speed and pour in one (1) pint of diesel fuel. Run the pump for about 20 to 30 seconds then move the vacuum/pressure valve to vacuum to blow out the diesel fuel. Repeat until the diesel fuel comes out clean.
3. After cleaning, pour in 2 oz. of recommended lubricating oil (See Step 1 of "Before Start of Season" on Page 37 for recommended oils). Reattach the vacuum and pressure hoses to the vacuum pump.

**Vacuum Pump Automatic Oiler Adjustment**

The oil pump is adjusted at the factory during final testing of the vacuum pump. Should the oil pump need adjusting:

1. Operate the pump at maximum allowed operating speed.
2. Remove the oil pump shield (Figure 60).
3. Remove the adjustment screw caps (Figure 61).

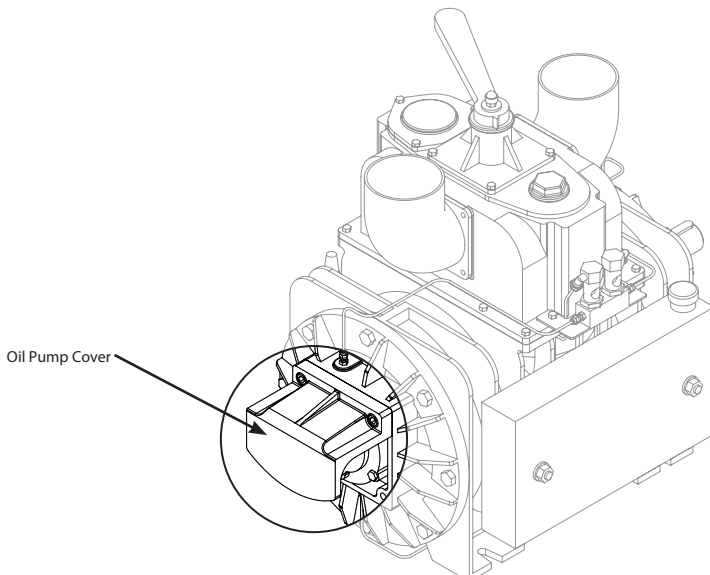
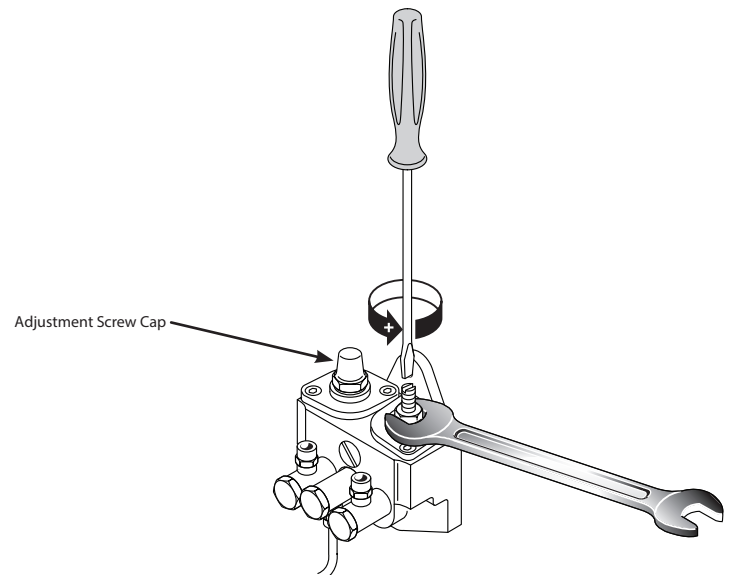
**Figure 60****Figure 61**

## Vacuum Pump Automatic Oiler Adjustment (Continued)

4. Use a short screwdriver and a 10mm wrench to adjust the oil flow. Rotate the adjustment screw  $\frac{1}{2}$  turn. Adjusting the screw clockwise will decrease the drip rate and adjusting counter-clockwise will increase the drip rate.
5. Check the oil drip rate after each  $\frac{1}{2}$  turn adjustment and continue adjusting if necessary. The drip rate should be between 15 and 20 drops in 30 seconds.
6. Replace the adjustment screw caps when the proper drip rate has been achieved.
7. Replace the oil pump shield.



**BALZER**

# Troubleshooting

## Steering Not Working Correctly

1. Make sure the steering hydraulic lever is in the "FLOAT" position.
2. Check the hydraulic connections to the tractor. The YELLOW coded hoses should be connected to the right side of the tractor's hydraulic bank. The hose with one (1) stripe should be connected to the RETURN port and the hose with two (2) stripes should be connected to the PRESSURE port.
3. Grease the kingpins (if equipped with grease points) and the tie rod. Apply grease to the kingpins with the wheels straight and also with the wheels fully extended to each turning position. The kingpins and tie rod must be greased daily for proper steering system operation.
4. If the system is still not steering properly, call Balzer's Service Department at 1-800-795-8551 Ext. 134 (or press 0 for the operator).

## Backing Up and Steering Not Locked Straight

1. Make sure the steering hydraulic lever is NOT in the "FLOAT" position.
2. Check the hydraulic connections to the tractor.
3. If the system is still not locking the steering wheels straight, call Balzer's Service Department at 1-800-795-8551 Ext. 134 (or press 0 for the operator).

## Hydraulic Controls Not Working Properly

1. Check the hydraulic connections to the tractor:

A. RED marked hose	Brakes
B. YELLOW marked hose	Steering System
C. GREEN marked hose	3-Way Valve or T-Valve
D. ORANGE marked hose	Down Pressure Block
E. BLUE marked hose	Hydraulic Motor
F. BLUE/GREEN marked hose	Hydraulic Motor Zero Return
2. Check the tractor's hydraulic fluid levels.
3. Check the hydraulic system for leaks or hose line damage.
4. Attach the tractor to a different implement to identify if the problem is with the tractor or the implement.
5. If the problem is with the tractor, contact your local farm equipment service center.
6. If the problem is with the implement, call Balzer's Service Department at 1-800-795-8551 Ext. 134 (or press 0 for the operator).

## Brakes Not Working Properly

1. Apply brakes.
2. Measure the compression of the pressure release spring.
  1. If the pressure release spring is compressed to 8" (20.3 cm) or less, hydraulic fluid must be added to the braking system (See "Brake System" on Page 35).

## PTO Not Working

1. Check that the PTO drive lever on the tractor is engaged.
2. Disengage the PTO, shut off the tractor, and remove the key.
3. Check that the PTO is connected to the tractor.
4. Check the PTO shaft's shear bolt. If the shear bolt is broken, damaged, or missing, replace and attempt PTO operation again.
5. Disconnect the PTO from the tractor and engage the PTO drive on the tractor. Check to see that the tractor's PTO shaft is turning. If the tractor's PTO shaft is not turning, contact your local farm equipment service center.
6. For additional troubleshooting of the PTO shaft, see the manufacturer's book that came with the PTO shaft.
7. If PTO is still not working, call Balzer's Service Department at 1-800-795-8551 Ext. 134 (or press 0 for the operator).

## Vacuum Pump Not Working

1. Check pump Vacuum/Pressure lever position.
2. Check the gate valves.
3. Check the hydraulic motor:
  - A. Check that the hydraulic lever controlling the hydraulic motor is engaged.

**TROUBLESHOOTING****Vacuum Pump Not Working (Continued)**

- B. Check hydraulic hoses for proper connection to tractor.
  - C. Check hydraulic hoses for leaks.
  - D. Check the tractor's hydraulic fluid levels.
4. Check vacuum and pressure hoses coming off the vacuum pump for any leaks.
  5. Check the flexible suction tube on the boom for any leaks.
  6. Check the vacuum pump's internal vanes for excessive wear.
  7. If the pump is still not working, call Balzer's Service Department at 1-800-795-8551 Ext. 134 (or press 0 for the operator),

**Slurry Pump Not Working**

1. Check if tank is empty.
2. Hydraulic Motor drive:
  - A. Check that the hydraulic lever controlling the hydraulic motor is engaged.
  - B. Check hydraulic hoses for proper connection to tractor.
  - C. Check hydraulic hoses for leaks.
  - D. Check the tractor's hydraulic fluid levels.
3. Check if the gate valves are open or closed.
4. If the pump is still not working, call Balzer's Service Department at 1-800-795-8551 Ext. 134 (or press 0 for the operator),

**Rite Rate Flow System****Raven SCS660 NVM Not Working**

1. Check to see if the Raven SCS660 Controller is turned on.
2. If the Raven SCS660 Controller is not turning on, turn off unit and check fuse on back of the controller (Figure 62). If fuse is blown, replace with a 15 AMP 32V Glass Tube fuse.
3. If the 15 AMP fuse is not blown, check the 20 AMP Blade Fuse that is located inline with the Red wire on the Raven SCS660 Console Cable attached to a key switched 12 VDC power source.
4. If the 20 AMP fuse is not blown, check the electrical connections:
  - A. Check that the Red wire connected to a key switched 12 VDC power source.

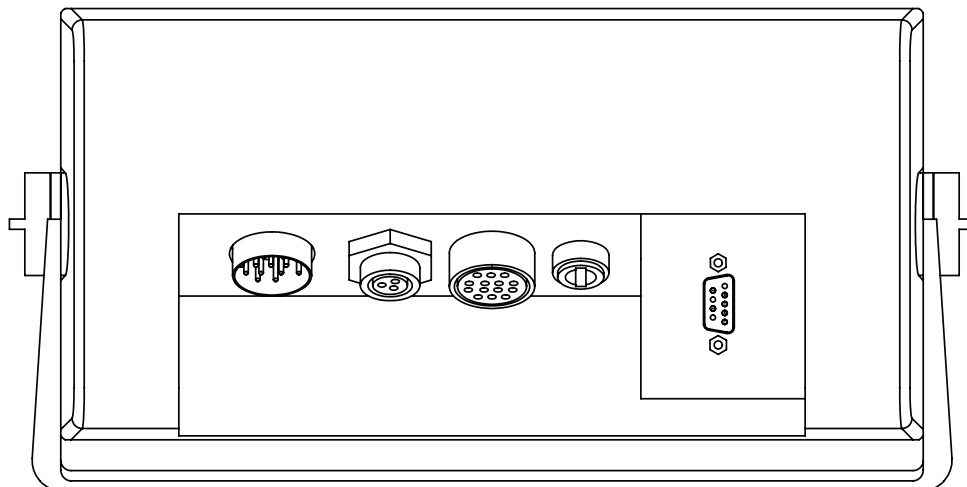
**Figure 62**

15 AMP Glass Tube Fuse



Fuse Cover



## Rite Rate Flow System (Continued)

- B. Check that the key switched 12 VDC power source is receiving power when the tractor key is in the operate/run position. If it is not receiving power, contact your local farm equipment service center.
- C. Check that the White wire is connected to a good tractor grounding point.
- 5. If both fuses are blown, there may be an issue with the tractor's electrical system. Contact your local farm equipment service center.
- 6. Was the tractor jump started, welded on, or connected to a battery charger and the Raven SCS660 NVM power connections still connected? If yes, the Raven SCS660 NVM may have received some internal electronic damage. Contact Balzer's Service Department at 1-800-795-8551 Ext. 134 (or press 0 for the operator).





### Raven SCS660 NVM Not Controlling Flow Properly

1. Check the Raven SCS660 NVM programming. If the programming is not correct, see "Rite Rate Flow System Programming".
2. If the programming is correct, check all connections between the Raven SCS660 NVM Controller and the
  - A. Krohne Optiflux 4100C
  - B. Raven 660 PWM Boost Box and down pressure block
  - C. Sky Trak GPS
3. Check if the Sky Trak GPS has an unobstructed view of the sky and check GPS on another GPS capable device (a GPS enabled highway navigation system, such as Garmin or TomTom, or a cellular telephone with GPS capabilities) to see if that device is able to obtain a GPS signal. GPS systems require communication with at least four GPS satellites.
4. Check the 1 AMP Blade Fuse that is inline with the Power Cable connected to the Krohne Flow Meter.
5. If the 1 AMP fuse is not blown, check for voltage at the fuse. If no voltage is present, recheck all connections between the flow meter and the Raven SCS660 Controller.
6. Check that the gate valves are open when the system is operating.
7. Check that the pump is operating properly.
8. If the flow is still not being properly controlled, call Balzer's Service Department at 1-800-795-8551 Ext. 134 (or press 0 for the operator).











## Rite Rate Flow System Programming

When programming data into console, press the desired data key, press enter, press the numbers, then press enter to accept.

Example: To program the Valve Cal

1. Press Valve Cal 
2. Press Enter 
3. Enter the numeric value (IE: 43 -  )
4. Press Enter 

Rite Rate Flow System Programming/Reprogramming Steps:

1. Turn Power on (if the display doesn't show **US VOLUME**, turn off the controller, then press and hold  while turning the controller on.)
2. Press  to accept **US - VOLUME**
3. Press  until the display shows to **SP2 - RADAR**, then press 
4. Press  to select **LIQUID SPRAYER**
5. Press  until the display shows **C-PC-PWM CLOSE VALVE**, then press 
6. Press Boom Cal   = 150  (this is the width of the plow/injector toolbar in inches)



## Rite Rate Flow System Programming (Continued)

7. Press the Up Arrow to check the remaining Booms. The value for the remaining booms should be 0.
8. Press Speed Cal ENTER = 598 (this is the value for the Sky Trak GPS)
9. Press Meter Cal ENTER = 50
10. Press Valve Cal ENTER = 43
11. Press Rate 1 Cal ENTER = 2500.0 (be sure to remember the 0 following the decimal point)
12. Press Rate 2 Cal ENTER = 3000.0

Rate 1 and Rate 2 can have any desired application flow rate, however, both need to have a flow rate entered to complete setup. These rates can be changed through this console after the setup is completed.

Record your settings for Boom Width, Rate 1, and Rate 2 for future reference should the controller need to be reprogrammed.

Boom Width (in Inches)	Rate 1	Rate 2

If the controller needs to be reprogrammed, press and hold while turning the power on then start with Step 2 above.

For additional information on the Raven SCS660 NVM Controller, see the manufacturer's manual that came with the unit.

For additional information on the Sky Trak GPS, see the manufacturer's manual that came with the unit.

For additional information on the Krohne Optiflux Flow Meter and Signal Converter, see the manufacturer's manuals that came with the unit.

## Rite Rate Console Cable Preparation

The Console cable should come prepared for immediate use. If needing to prepare the Console Cable, use the following steps.

1. Open wire loom and pull the Orange wire back towards the 16-pin plug until it is about halfway between the 16-pin plug and where the Red and White wires exit the Console Cable.
2. Pull the Blue wire out enough to make a small loop.
3. Cut the Orange wire and the Blue wire (Figure 63).

Figure 63

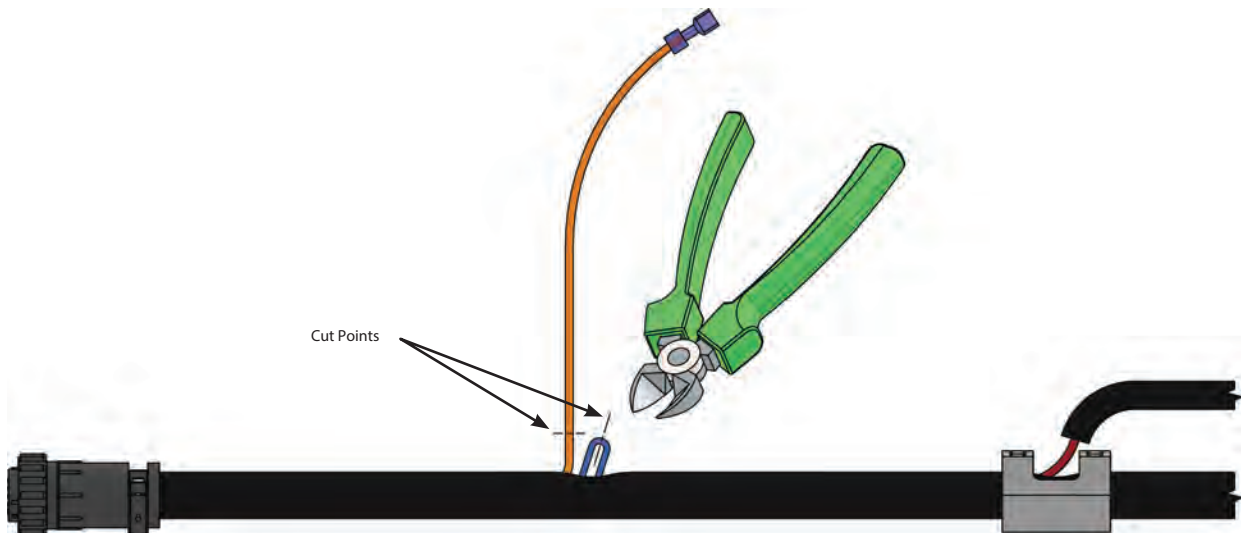

## Rite Rate Console Cable Preparation (Continued)

4. Push the Blue wire leading to the 16-pin plug back into the wire loom (this wire is not needed).
5. Strip about 3/8" to 1/2" of both cut Orange wire ends and the remaining Blue wire end.
6. Assemble the wires as shown in Figure 64. Use a heat shrink solder connector with a heat gun (this will solder the wires together and shrink seal the ends) or twist the exposed wires together and solder with a soldering iron. **DO NOT** use crimp connectors for this connection as they can work themselves loose and create an intermittent connection.
7. If using a soldering iron, after the solder has cooled, use electrical tape to wrap the wires from about 1" above the joint to about 1" below the joint.
8. Push the soldered and sealed joint back into the wire loom leaving only the Orange wire tail exposed.

Figure 64

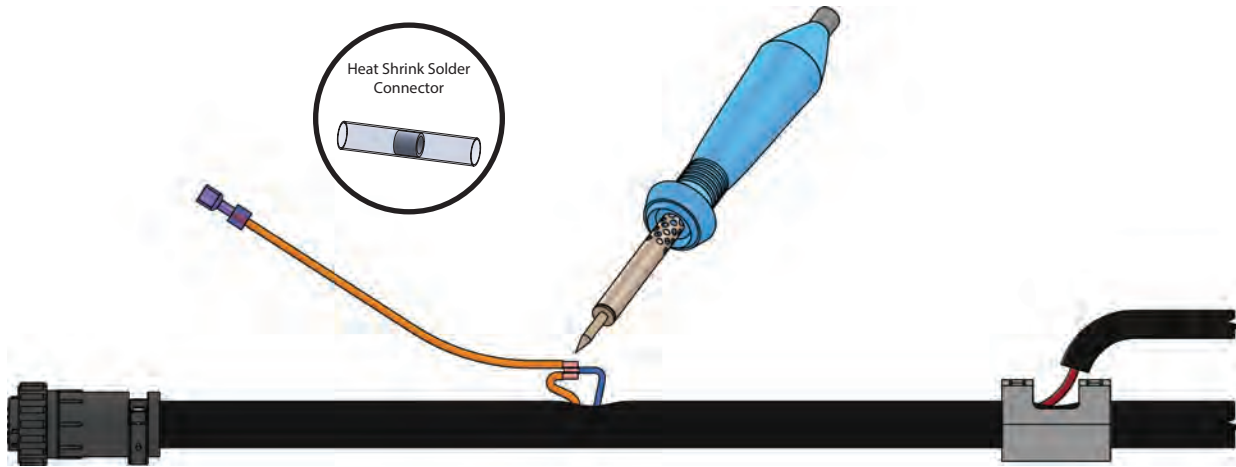

## Rite Rate Wiring Installation

Figure 65 shows the Rite Rate system wiring installation and connections.

1. Connect the 16-pin plug on the Console Cable to the 16-pin receptacle on the back of the Raven SCS660 Controller.
2. Connect the 3-pin plug on the Sky Trak GPS to the 3-pin receptacle on the back of the Raven SCS660 Controller.
3. Connect the Orange wire of the Console Cable to the Blue wire of the Sky Trak GPS.
4. Place the Sky Trak GPS as high as possible on the tractor in a space that will allow the Sky Trak GPS unrestricted exposure to the sky. The Sky Trak GPS has a magnetic base for placement on a metal surface for mounting.
5. Connect both connectors of the Console Cable to the Flow Control Cable.
6. Connect a White wire of the Flow Control Cable to the White wire of the Raven 660 Boost Box.
7. Connect the Yellow/Green wire connector of the Flow Control Cable to the Yellow/Green wire connector of the Raven 660 Boost Box.
8. Connect the Black wire of the Flow Control Cable to the Red wire of the Raven 660 Boost Box.
9. Connect the wires from the Raven 660 Boost Box to the Down Pressure Block.
10. Connect the Blue wire of the Flow Control Cable to the Red wire of the Power Cable to the Flow Meter.
11. Connect a White wire of the Flow Control Cable to the Black wire of the Power Cable to the Flow Meter.
12. Connect the 3-pin connector of the Flow Control Cable to the 3-pin connector of the Extension Cable.
13. The remaining White wire and the Brown wire of the Flow Control Cable are not used. Wrap the ends with electrical tape to protect the connectors.
14. Connect the 4-pin connector of the Power Cable to the 4-pin connector of the Krohne Flow Meter.
15. Connect the 3-pin connector of the Extension Cable to the 3-pin connector of the Krohne Flow Meter.
16. Return to the Console Cable and connect the White wire from the smaller wire loom to the Tractor Ground.
17. Connect the Red wire from the smaller wire loom to a Key Switched +12 VDC power source.

## Rite Rate Wiring Installation (Continued)

Figure 65

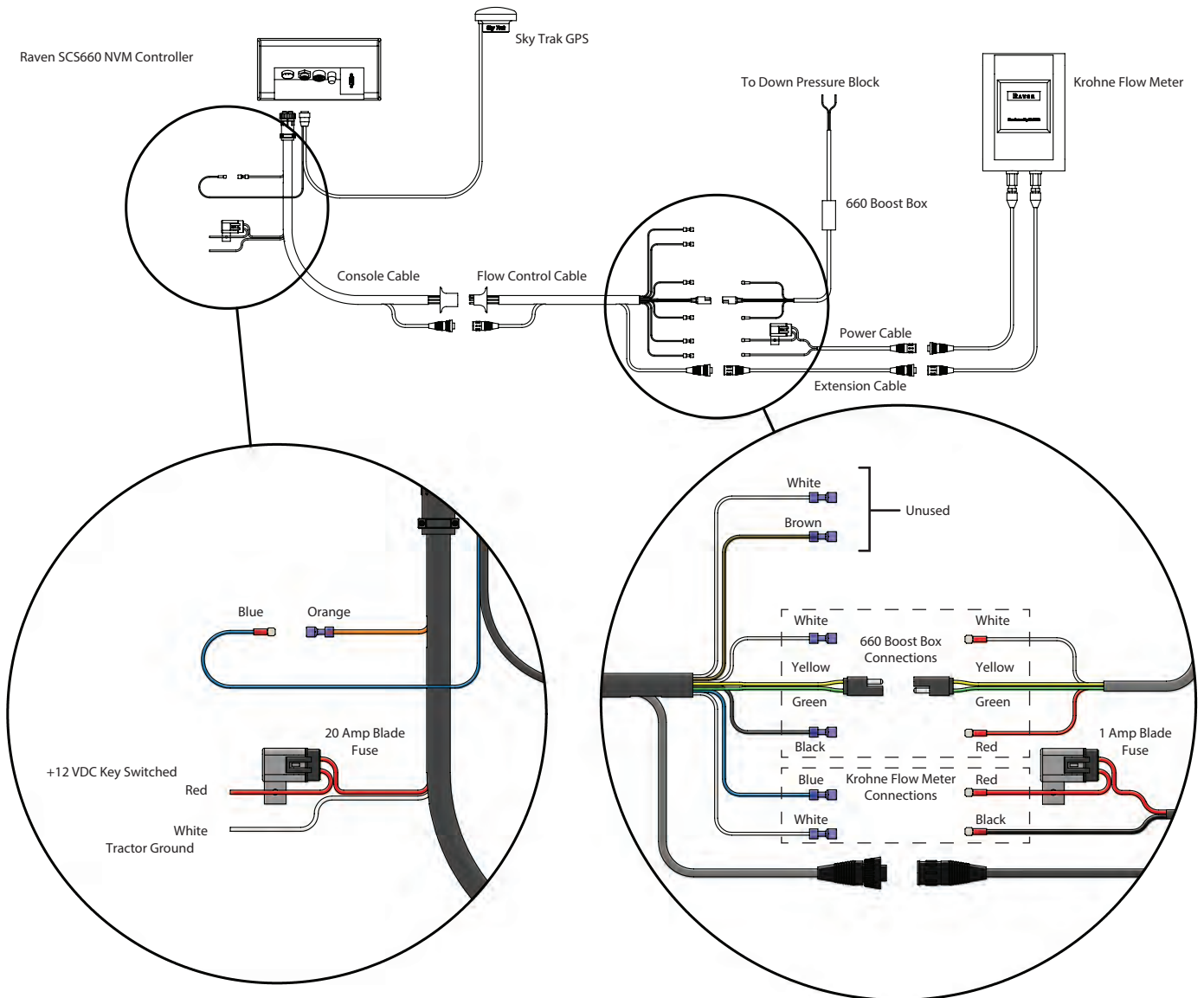





**BALZER**

# Notes

Date

Notes

---

---

---

---

---

---

---

---

---

---

---

---

---

---

---

---

---

---

---

---



Date

Notes

---

---

---

---

---

---

---

---

---

---

---

---

---

---

---

---

---

---

---

---







## **Eliminator Vacuum Tanks (Tandem)**

User Manual  
UM-EVT-1



Balzer Incorporated reserves the right to make changes to their product and/or this manual to improve reliability, function, design, or safety without further notice. Balzer Incorporated is under no obligation, implied or otherwise, to upgrade, modify, or otherwise make changes to product manufactured prior to any design change.

Balzer Incorporated does not assume any liability arising out of the application or use of any product and neither does it convey any license under its patent rights. Balzer Incorporated does not assume any liability arising out of the use of their product for applications outside those for which it is expressly designed for.

**© 2014 Balzer Inc. All Rights Reserved**